



VILLAGER

Your satisfaction is our #1 goal. If you have questions or concerns with your vehicle, we suggest you follow these steps:

1. Contact your Sales Representative or Service Advisor at your selling/servicing dealership.
2. If the inquiry or concern remains unresolved, contact the Sales Manager or Service Manager at the dealership.
3. If the inquiry or concern cannot be resolved at the dealership level, please contact the Ford Customer Assistance Center.

In the United States:

Ford Motor Company
Customer Assistance Center
300 Renaissance Center
P.O. Box 43360
Detroit, MI 48243
1-800-392-3673 (FORD)
TDD for the hearing impaired: 1-800-232-5952

In Canada:

Customer Assistance Centre
Ford Motor Company of Canada, Limited
P.O. Box 2000
Oakville, Ontario L6J 5E4
1-800-565-3673 (FORD)

Outside the U.S. or Canada:

FORD MOTOR COMPANY
WORLDWIDE EXPORT OPERATIONS
1555 Fairlane Drive
Fairlane Business Park #3
Allen Park, Michigan 48101
Telephone: (313) 594-4857
Fax: (313) 390-0804

All rights reserved. Reproduction by any means, electronic or mechanical, including photocopying, recording, or by any information storage and retrieval system or translation in whole or part is not permitted without written authorization from Ford Motor Company.

Copyright © 1996 Ford Motor Company

Table of Contents

Introductory Information	1
Safety Restraints	9
Starting Your Villager	57
Warning Lights and Gauges	67
Instrument Panel Controls	89
Steering Column Controls	123
Features	135
Adjustable Rear Seating	175
Electronic Sound Systems	205
Driving Your Villager	229
Roadside Emergencies	255
Customer Assistance	275
Reporting Safety Defects	281
Accessories	287
Servicing Your Villager	295
Quick Index	375
Index.	385
Service Station Information	404

Introductory Information

Using This Guide

To fully appreciate all of the features and options of your new vehicle, we recommend that you thoroughly read through this guide now and refer back to it when you have specific needs or questions. For your own safety and the safety of your passengers, it is important that you completely understand **all** performance and care procedures **before** operating this vehicle. For example, without reading further, would you know:

- What to do if you get a flat tire? (Refer to *Flat tire* in the Index)
- What it means if the O/D OFF light is illuminated on your instrument panel? (Refer to *Overdrive* in the Index)
- How to engage the childproof safety lock on the sliding door? (Refer to *Childproof lock* in the Index)
- That your automatic transaxle will not shift out of PARK (P) until you depress the brake pedal? (Refer to *Gearshift* in the Index)

Ford's Commitment to You

At Ford Motor Company, excellence is the continuous commitment to achieve the best result possible. It is dedication to learning what you want, determination to develop the right concept, and execution of that concept with care, precision, and attention to detail. In short, excellence means being the standard by which others are judged.

Our Guiding Principles

- **Quality comes first.** For your satisfaction, the quality of our products and services must be our number one priority.
- **You are the focus of everything we do.** Our work must be done with you in mind, providing better products and services than our competition.

-
- **Continuous improvement is essential to our success.** We must strive for excellence in everything we do: in our products — in their safety and value — and in our services, our human relations, our competitiveness, and our profitability.
 - **Employee involvement is our way of life.** We are a team. We must treat one another with trust and respect.
 - **Dealers and suppliers are our partners.** We must maintain mutually beneficial relationships with dealers, suppliers, and our other business associates.
 - **Integrity is never compromised.** Our conduct worldwide must be pursued in a manner that is socially responsible and commands respect for its integrity and for its positive contributions to society.

Things to Know About Using This Guide

Congratulations on the purchase of your new vehicle. This guide has information about the equipment and the options for your new vehicle. You may not have bought all of the options available to you. If you do not know which information applies to your vehicle, talk to your dealer.

This guide describes equipment and gives specifications for equipment that was in effect when this guide was approved for printing. Ford may discontinue models or change specifications or design without any notice and without incurring obligation.

NOTES and WARNINGS

NOTES give you additional information about the subject matter you are referencing.

WARNINGS remind you to be especially careful in those areas where carelessness can cause damage to your vehicle or personal injury to yourself, your passengers or other people. Please read all **WARNINGS** carefully.

Introductory Information

 WARNING

Finding Information in This Guide

After you have read this guide once, you will probably return to it when you have a specific question or need additional information. To help you find specific information quickly, you can use the Quick Index, Table of Contents, or the Index.

The **Quick Index** at the end of the book provides a page number following each item which indicates where detailed information can be found.

To use the **Index**, turn to the back of the book and search in the alphabetical listing for the word that best describes the information you need. If the word you chose is not listed, think of other related words and look them up. We have designed the Index so that you can find information under a technical term.

Canadian Owners — French Version

French Owner Guides can be obtained from your dealer or by writing to Ford Motor Company of Canada, Limited, Service Publications, P.O. Box 1580, Station B, Mississauga, Ontario L4Y 4G3.

Maintenance Schedule

As with any other member of your family, your new vehicle requires routine care and regular check-ups. A separate *Maintenance Schedule and Record* booklet is included to help you keep track of all services performed and summarizes the day-to-day services that are most important for keeping your vehicle in good condition.

Warranties

Your vehicle is covered by three types of warranties: **Basic Vehicle Warranty**, **Extended Warranties** on certain parts, and **Emissions Warranties**.

Read your *Warranty Information Booklet* carefully to find out about your vehicle's warranties and your basic rights and responsibilities.

If you lose your *Warranty Information Booklet*, you can get a new one free of charge. Contact any Ford or Lincoln-Mercury dealer, or refer to the addresses and phone numbers on the first page of this owner guide.

Ford's Extended Service Plan (ESP®)

More Protection for Your Vehicle

You can get more protection for your new car or light truck by purchasing a Ford Extended Service Plan (Ford ESP). Ford ESP is the only extended service program with the Ford name on it and the only service contract backed by Ford Motor Company.

Ford ESP is an optional service contract, backed and administered by Ford. It provides:

- protection against repair costs after your Bumper to Bumper Warranty expires;
- and
- other benefits during the warranty period (such as: reimbursement for rentals; coverage for certain maintenance and wear items).

You may purchase Ford ESP from any participating Ford Motor Company dealer. There are several Ford ESP plans available in various time-and-mileage combinations. Each plan can be tailored to fit your own driving needs, including reimbursement benefits for towing and rental. (In Hawaii, rules vary. See your dealer for details.)

Introductory Information

When you purchase Ford ESP, you receive peace-of-mind protection throughout the United States and Canada, provided by a network of more than 5,100 participating Ford Motor Company dealers.

NOTE: Repairs performed outside the United States and Canada are not eligible for ESP coverage.

This information is subject to change. Ask your dealer for complete details about Ford ESP coverage.

Break-In Period for Your Villager

Your new vehicle will go through an adjustment or break-in period during the first 1,000 miles (1,600 km) of driving. During the break-in period, you need to pay careful attention to how you drive your vehicle.

- **Change your speed often as you drive.** Do not drive at one speed for a long time.
- **Use only the type of engine oil that Ford recommends.** See *Engine oil recommendations* in the Index. Do not use special “break-in” oils.
- **Avoid sudden stops.** Because your vehicle has new brake linings, you should take these steps:
 - Watch traffic carefully so that you can anticipate when to stop.
 - Begin braking well in advance.
 - Apply the brakes gradually.

The break-in period for new brake linings lasts for 100 miles (160 km) of city driving or 1,000 miles (1,600 km) of highway driving.

Cleaning the Outside of Your Villager

Washing and Polishing Your Vehicle

Wash the outside of your vehicle, including the underside, with a mild detergent.

DO NOT:

- Wash your vehicle with hot water
- Wash your vehicle while it sits in direct sunlight
- Wash your vehicle while the body is hot

Pollen, bird droppings and tree sap can damage the paint, especially in hot weather. Wash your vehicle as often as necessary to keep it clean.

Take similar precautions if your vehicle is exposed to chemical industrial fallout.

Paint damage resulting from fallout is not related to a defect in paint materials or workmanship and therefore, is not covered by warranty. Ford, however, believes that continual improvement in customer satisfaction is a high priority. For this reason, Ford has authorized their dealers to repair, at no charge to the owner, the surfaces of new vehicles damaged by environmental fallout within 12 months or 12,000 miles (20,000 km) of purchase, whichever comes first. Customers may be required to bring their vehicle in for inspection by a Ford representative.

Polish your vehicle to remove harmful deposits and protect the finish.

Introductory Information

Cleaning Chrome and Aluminum Parts

Wash chrome and aluminum parts with a mild detergent. Do not use steel wool, abrasive cleaners, fuel or strong detergents.

Cleaning Plastic Parts

Some of your vehicle's exterior trim parts are plastic. Clean with a tar and road oil remover if necessary. Use a vinyl cleaner for routine cleaning.

Do not clean plastic parts with thinners, solvents or petroleum-based cleaners.

If you have your vehicle rustproofed, remove oversprayed rustproofing with a tar and road oil remover. If rustproofing is not removed from plastic and rubber parts, it can cause deterioration.

Safety Restraints

Important Safety Belt Information

The use of safety belts helps to restrain you and your passengers in case of a collision. In most states and in Canada the law requires their use.

Safety belts provide best restraint when:

- the seatback is upright
- the occupant is sitting upright (not slouched)
- the lap belt is snug and low on the hips
- the shoulder belt is snug against the chest
- the knees are straight forward

To help you remember to fasten your safety belt, a warning light may come on and a chime may sound. See *Safety Belt Warning Light and Chime* in the *Warning Lights and Gauges* chapter.

See the following sections in this chapter for directions on how to properly use these safety belts. Also see *Safety Restraints for Children* in this chapter for special instructions about using safety belts for children.

R WARNING
Make sure that you and your passengers wear safety belts. Always drive and ride with your seatback upright and the lap belt snug and low across the hips.

R WARNING

Never wear the shoulder belt under the arm. Never swing it around the neck over the inside shoulder. Never use a single belt for more than one person or across more than one seating position. Each seating position in your vehicle has a specific safety belt assembly which is made up of one buckle and one tongue that are designed to be used as a pair. Failure to follow these precautions could increase the risk and/or severity of injury in a collision.

R WARNING

Never drive or ride with a twisted or jammed safety belt. If you cannot untwist or unjam the safety belt, see the nearest qualified technician immediately.

R WARNING

Children should always ride with the seatback in the fully upright position. When the seatback is not fully upright, there is a greater risk that the child will slide under the safety belt and be seriously injured in a collision.

R WARNING

Never let a passenger hold a child on his or her lap while the vehicle is moving. The passenger cannot protect the child from injury in a collision.

R WARNING

Lock the doors of your vehicle before driving to lessen the risk of the door coming open in a collision.

Safety Restraints

Combination Lap and Shoulder Belts

While your vehicle is in motion, the combination lap and shoulder belt adjusts to your movement. However, if you brake hard, turn hard, or if your vehicle receives an impact of 5 mph (8 km/h) or more, the lap and shoulder belt locks and helps to reduce your forward movement.

After you get into your vehicle, close the door and lock it. Then adjust the seat to the position that suits you best.

To fasten the belt, pull the combination lap and shoulder belt from the retractor so that the shoulder portion of the belt crosses your shoulder and chest. Be sure the belt is not twisted. If it is, remove the twist. Insert the belt tongue into the proper buckle until you hear a snap and feel it latch. Make sure the tongue is securely fastened to the buckle by pulling on tongue.

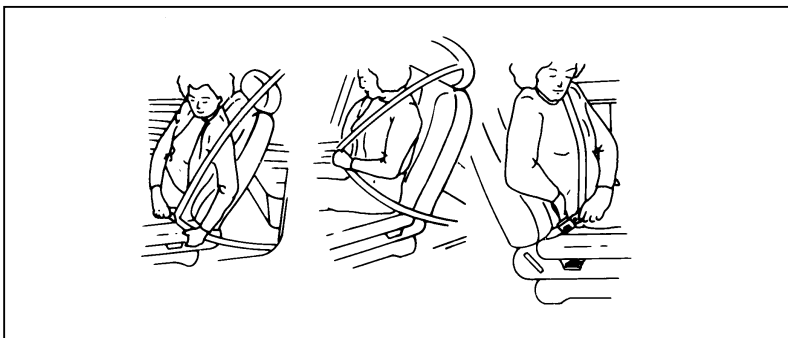

Fastening the front seat combination lap and shoulder belt

NOTE: Be sure to read and understand *Important Safety Belt Information* at the beginning of this chapter.

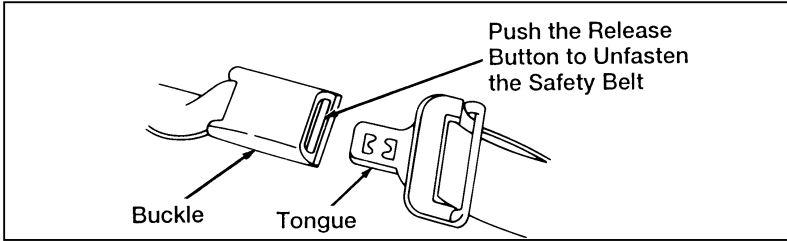

Unfastening the combination lap and shoulder belts — front and rear outboard seating positions

Third-row passengers should be aware that the proper safety belt for their seating position is slightly behind their seat. They should not use the second-row safety belts which are in front of the third seat.

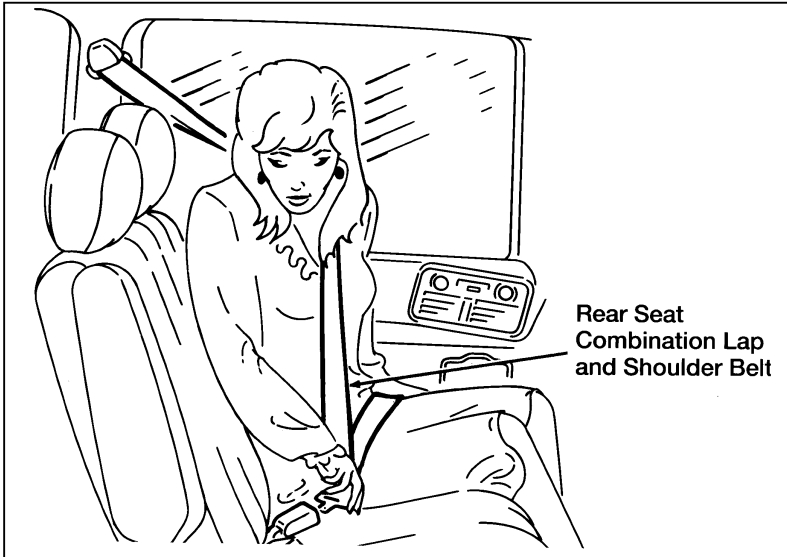

Fastening the rear seat combination lap and shoulder belt

Safety Restraints

R WARNING

<p>Use the shoulder belt on the outside shoulder only. Never wear the shoulder belt under the arm. Never swing it around the neck over the inside shoulder. Never use a single belt for more than one person. Failure to follow these precautions could increase the risk and/or severity of injury in a collision.</p>
--

To tighten the lap portion of the belt, pull up on the shoulder belt until it fits you snugly. The belt should rest as low on your hips as possible.

The passenger seated near the sliding door in the three-passenger bench seat can route the safety belt webbing under the guide located on the head restraint. This safety belt guide is designed to help keep the safety belt webbing properly positioned across the passenger's chest for maximum comfort. This guide is only needed when the two-passenger second row bench seat is removed and the three-passenger bench seat is moved up to the second-row position.

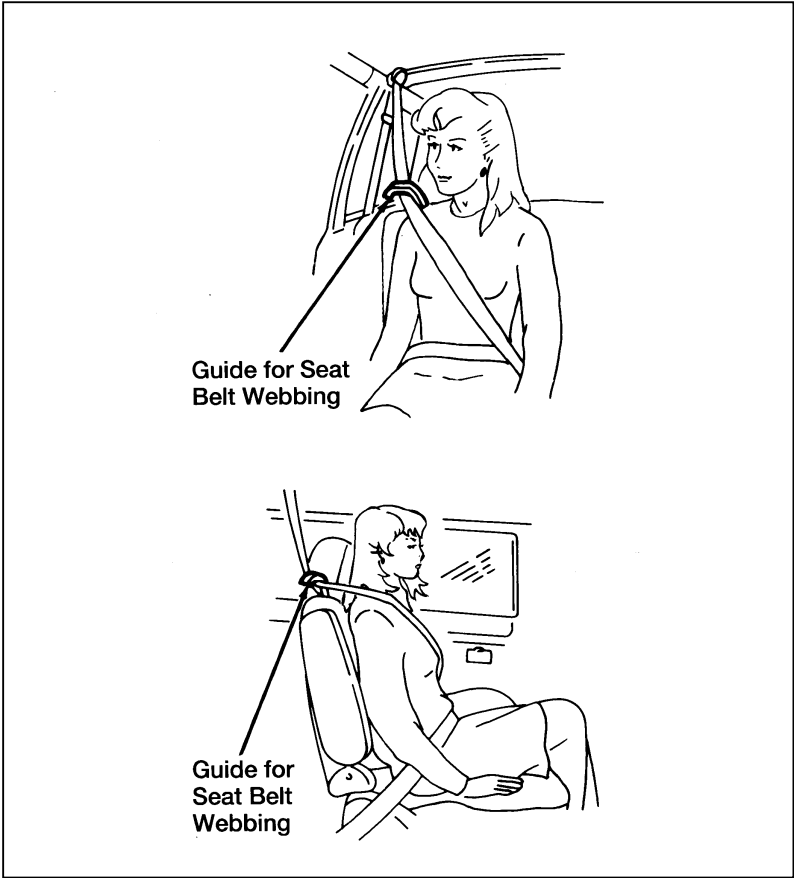

Using the seat belt guide with the three-passenger bench seat in the second row position

Safety Restraints

NOTE: The second row two-passenger bench seat has a unique safety restraint system. If your vehicle has the two-passenger bench seat it is very important that the unique safety belt system is used properly. Please read *Auxiliary safety restraint system for the second row bench seat* in this section, which explains the unique safety belt system. Be sure that you understand it before anyone rides in the two-passenger bench seat.

Passenger Outboard Lap/Shoulder Belts

All seats except the driver's seat and the third seat middle position are equipped with a dual locking mode retractor on the shoulder belt portion of the lap/shoulder safety belt. (The driver's seat has only a vehicle sensitive locking mode and the third seat middle position has a lap belt without a retractor—description follows.)

Dual Locking Mode Retractors Operate in Two Ways:

Vehicle sensitive (emergency) locking mode

In this operating mode, the shoulder belt retractor will allow the occupant freedom of movement, locking tight only on hard braking, hard cornering or impacts of approximately 5 mph (8 km/h) or more.

Automatic locking mode

In this operating mode, the shoulder belt retractor will be automatically locked and will remain locked when the combination lap/shoulder safety belt is buckled, and does not allow the occupant freedom of movement. This mode provides the following:

- A tight lap/shoulder belt on the occupant.
- Child safety seat installation.

R WARNING

Rear-facing infant seats or infant carriers should never be placed in the front seats.

This mode **must be used** when installing a child safety seat on the front passenger seat and rear outboard seats where dual locking retractors are provided.

To switch the retractor from the emergency locking mode to the automatic locking mode, perform the following steps:

1. Buckle the lap/shoulder combination belt.
2. Grasp the shoulder portion of the belt and pull downward until all of the belt is extracted and, when allowed to retract, a clicking sound is heard. At this time, the belt retractor is in the automatic locking mode (child restraint mode).
3. A clicking sound will continue to be heard as the belt is allowed to retract. This indicates that the retractor is in the automatic locking mode.

NOTE: When the combination lap/shoulder belt is unbuckled and allowed to retract completely, the retractor will switch to the vehicle sensitive (emergency) locking mode. See the detailed instructions under *Safety Seats for Children* in this chapter.

Safety Restraints

Shoulder Belt Height Adjustment

Driver and right front passenger

You can adjust the shoulder belt height to one of five (5) positions.

To adjust the belt down, pinch the release button. To adjust the belt up, pinch the release button and slide the adjuster up.

Make sure the adjuster is firmly in one of the five positions. The belt should be adjusted up or down until the belt rests on your shoulder near your neck.

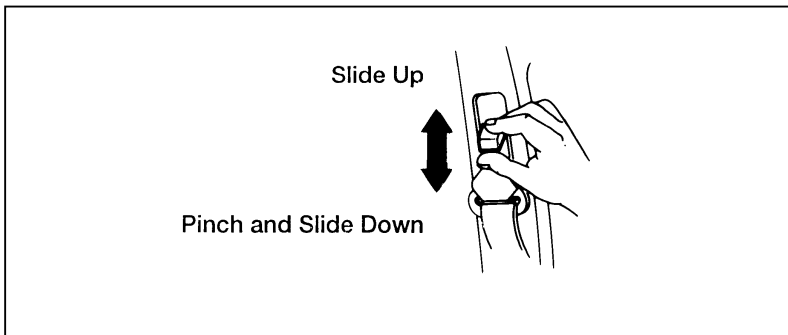

The shoulder belt height adjuster

R **WARNING**

Position the shoulder belt height adjuster so that the belt rests across the middle of your shoulder. Be sure the shoulder belt is properly positioned on your shoulder each time you use the belt. If the shoulder belt is off your shoulder, on your upper arm or neck, there is a greater risk of severe injury in a collision.

Lap Belt Without a Retractor (for the three-passenger bench seat)

The center seat of the three-passenger bench seat has a lap belt without a retractor. To make the belt longer, tip the tongue at a right angle to the belt and pull the belt over your lap until the tongue reaches the buckle.

To fasten the belt, pull the belt across your hips and insert the tongue into the correct buckle on your seat until you hear a snap and feel it lock. Make sure the buckle is securely fastened.

Adjust the belt so that it fits snugly and as low as possible around the hips:

- If you need to lengthen the belt, unfasten it and repeat the procedure above.
- If you need to shorten the belt, pull on the loose end of the webbing.

To store the belt:

Fasten the center tongue and buckle when not in use. This will prevent the belt from falling between the seat and the seatback.

Auxiliary Safety Restraint System for the Second Row Bench Seat (7 passenger vehicle)

There is a unique safety restraint system for the outside seating position of the second row bench seat. It is very important that you read and understand this section before anyone rides in the outside seating position (near the sliding door) of the two-passenger bench seat.

The two-passenger bench seat in the second row has a safety restraint system made up of two buckles and two tongues. There is an anchor location at the bottom of the C-pillar and another anchor location at the top of the C-pillar that attach each end of the seat belt webbing to the bodyside.

Safety Restraints

One of the seat belt tongues has two “windows” (or holes) and the other has only one “window.” The seat belt tongue with one window attaches to the buckle mounted to the side of the seat. The seat belt tongue with two windows should be pulled across the passenger’s chest and fastened to the buckle mounted in the standard location in the middle of the seat.

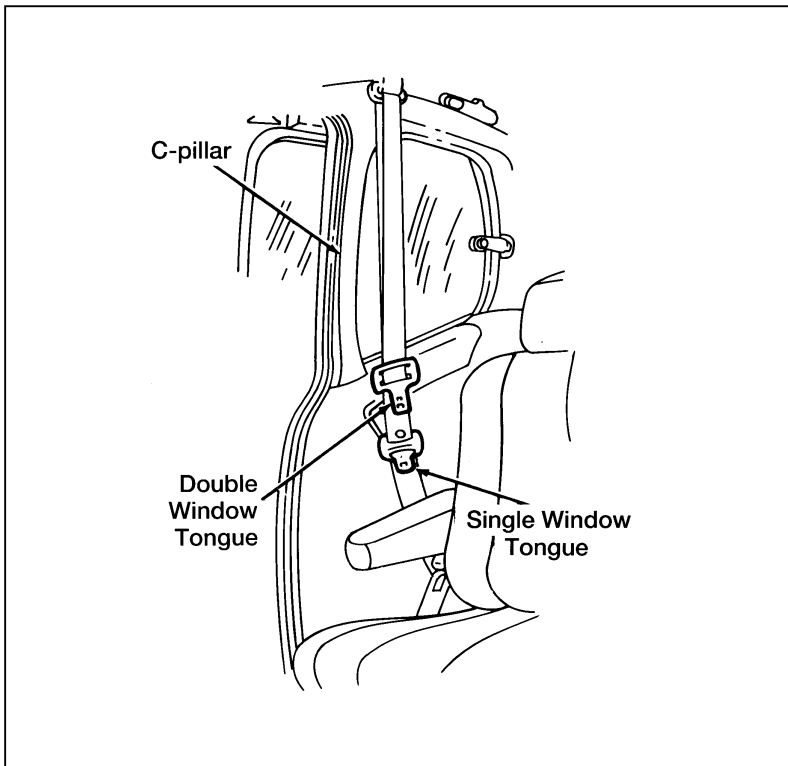

The auxiliary safety restraint system for the second row bench seat

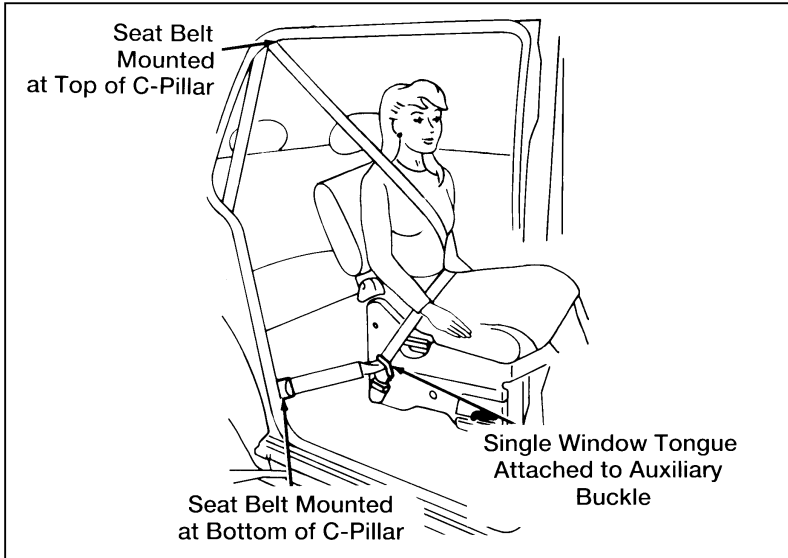

The auxiliary safety restraint system fastened

A twisted belt may prevent the retractor from working properly. If the unique safety belt system is twisted, disengage the single window tongue from the buckle on the side of the seat, remove the twist and re-install the tongue into the buckle until you hear a snap and feel the latch engage.

NOTE: If the three-passenger bench seat is moved up to the second-row position, the outside passenger (near the sliding door) only needs to use the double window tongue and the standard buckle. Because the third-row seat is wider and is closer to the sliding door, the single window tongue and the auxiliary buckle are not necessary.

Safety Restraints

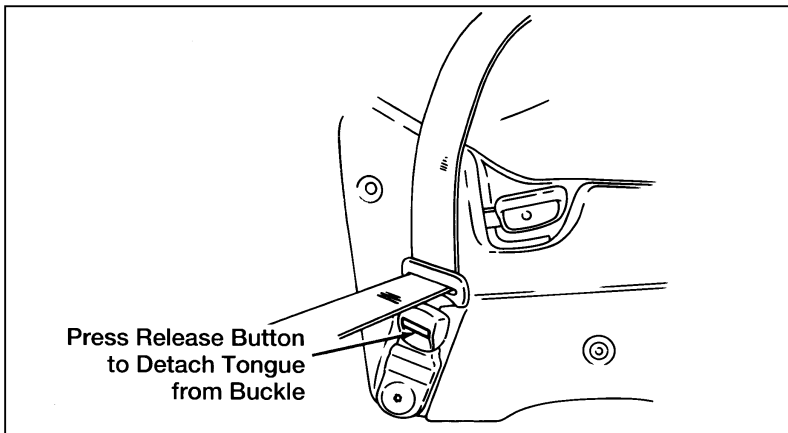

Unfastening the auxiliary safety restraint system

Both tongues must be attached to their appropriate buckles whenever someone is riding in that seating position.

When the two-passenger bench seat is removed from the vehicle, you must detach the single window tongue from the auxiliary buckle.

Third-row passengers must be very careful when exiting if the auxiliary restraint system is being used by a second-row passenger. It is important to step over the seat belt guide and belt webbing to avoid tripping.

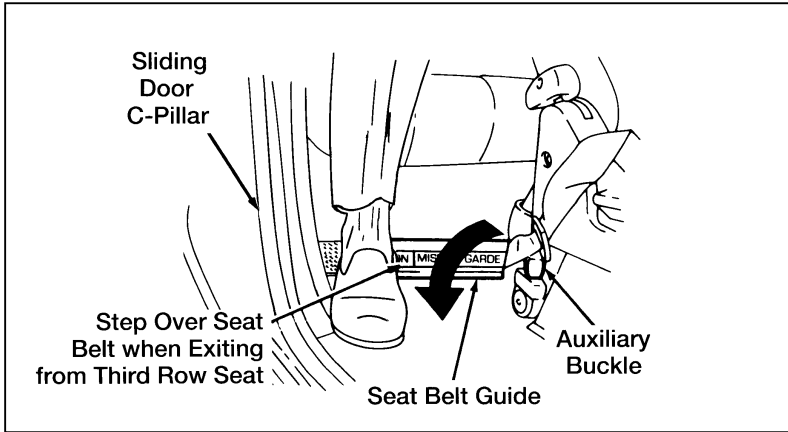

Exiting a vehicle with the auxiliary safety restraint system

Labels are provided on the back of the second-row bench seat to remind passengers to use care when exiting.

Safety Belt Extension Assembly

A safety belt may be too short even when it is fully extended. You can add about eight inches (20 cm) to the belt length with a safety belt extension assembly. Safety belt extensions are available at no cost (part number 611C22) from your dealer.

R WARNING

Failure to follow these instructions will affect the performance of the safety belts and increase the risk of personal injury.

Safety Restraints

Safety Belt Maintenance

Check the safety belt systems periodically to make sure that they work properly and are not damaged.

All safety belt assemblies, including retractors, buckles, front seat belt buckle support assemblies (slide bar) (if so equipped), child safety seat tether bracket assemblies (if so equipped), and attaching hardware, should be inspected after any collision. Ford recommends that all safety belt assemblies used in vehicles involved in a collision be replaced. However, if the collision was minor and a qualified technician finds that the belts do not show damage and continue to operate properly, they do not need to be replaced. Safety belt assemblies not in use during a collision should also be inspected and replaced if either damage or improper operation is noted.

Cleaning the Safety Belts

Clean the safety belts with any mild soap solution that is recommended for cleaning upholstery or carpets. Do not bleach or dye the belt because this may weaken it.

Air Bag Supplemental Restraint System (SRS)

The driver and right front passenger air bags are Supplemental Restraint Systems (SRS), provided at these seating positions in addition to the lap/shoulder belt, and are designed to supplement the protection provided to properly belted occupants in moderate to severe frontal collisions. The supplemental air bag system does not provide restraint to the lower body.

The Importance of Wearing Safety Belts

R WARNING

Safety belts must be worn by all vehicle occupants to be properly restrained and help reduce the risk of injury in a collision.
--

R WARNING

All occupants of the vehicle, including the driver, should always wear their safety belts, even when an air bag Supplemental Restraint System is provided.

There are four very important reasons to use safety belts even with a supplemental air bag system. Use your safety belts to:

- help keep you in the proper position when the supplemental air bag inflates
- reduce the risk of harm in rollover, side or rear impact accidents. The air bag supplemental restraint system is not designed to inflate in such situations
- reduce the risk of harm in frontal collisions that are not severe enough to activate the supplemental air bag
- reduce the risk of being thrown from your vehicle

The Importance of Being Properly Seated

In a collision, the air bag must inflate extremely fast to help provide additional protection for you. In order to do this, the air bag must inflate with considerable force. If you are not seated in a normal riding position with your back against the seatback, the air bag may not protect you properly and could possibly hurt you as it inflates.

Safety Restraints

R WARNING

If a passenger is not properly seated and restrained, an inflating air bag could cause serious injury.

R WARNING

Rear-facing infant seats should never be placed in the front seat.

In rear-facing infant seats, the infant's head is closer to the air bag. The force of the rapidly inflating air bag could push the top of the rear-facing seat against the vehicle seatback or center armrests (if so equipped), or center console (if so equipped). **REAR-FACING INFANT CARRIERS MUST ALWAYS BE SECURED IN THE REAR SEAT**, and other child safety seats and infant seats should be secured in the rear seat whenever possible.

Your vehicle is equipped with a right front passenger air bag. Air bags deploy with great force, faster than the blink of an eye. Front passengers, especially children and small adults, must never sit on the front edge of the seat, stand near the glove compartment of the instrument panel, or lean over near the air bag cover when the vehicle is moving. All occupants should sit with their backs against the seatback, move the seat to the most rearward position if possible and use the safety belts. Children weighing less than 40 lbs. (18 kg) always should use child or infant seats.

R WARNING

When using forward-facing child seats move the passenger seat as far back from the instrument panel as possible. NEVER SECURE REAR-FACING INFANT SEATS IN THE FRONT SEAT.
--

The force of the rapidly inflating passenger air bag could push the top of the rear-facing seat against the vehicle seatback, armrests or console. Rear-facing infant seats must always be secured in the rear seat.

R WARNING

Do not place objects or mount equipment on or near the air bag cover on the steering wheel or in front seat areas that may come in contact with a deploying air bag. Failure to follow this instruction may increase the risk of personal injury in the event of a collision.

For further information about the proper mounting of equipment in the front seat of this vehicle, please refer to Ford's brochure entitled *Some Important Information About Air Bag Supplemental Restraint System* which can be obtained by calling Helm Inc. at 1-800-782-4356. Ask for brochure FPS-8602.

For additional important safety information on the proper use of seat belts, child seats, and infant seats, please read the other sections of this chapter of the Owner Guide, especially sections entitled *Safety Belts for Children* and *Safety Seats for Children*.

How the Air Bag Supplemental Restraint System Operates

The Air Bag Supplemental Restraint System consists of the driver and passenger air bags, impact sensors, a system diagnostic module, a readiness light and tone, and the electrical wiring which connects the components.

The driver air bag is in the center of the steering wheel. The front passenger seat air bag is located in the center of the instrument panel ledge above the glove compartment. Both air bags are designed to stay out of sight until they are activated.

Safety Restraints

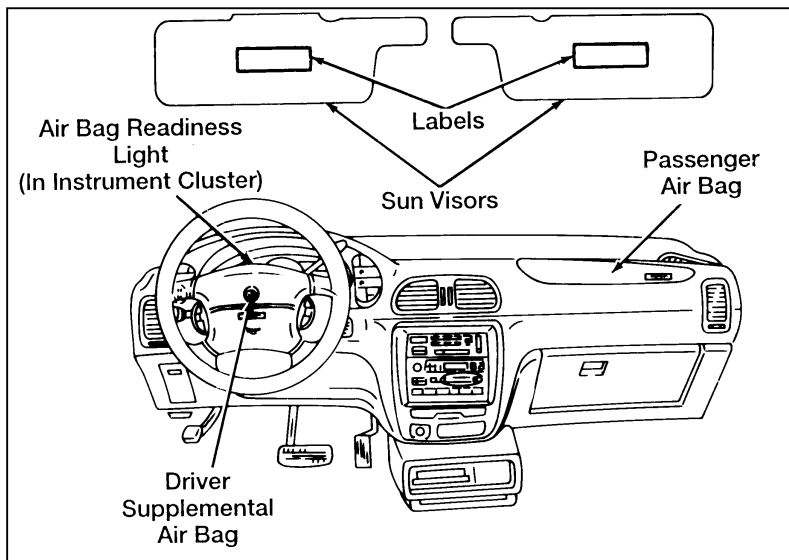

The location of air bags and warning labels

If a collision occurs, the sensors sense the severity of the impact and activate the air bags if necessary. The air bag system is designed to deploy in frontal and front-angled collisions more severe than hitting a parked vehicle (of similar size and weight) head-on at about 28 mph (45 km/h). Because the system senses the crash severity rather than vehicle speed, some frontal collisions at speeds above 28 mph (45 km/h) will not inflate the air bag.

When the sensors activate the system, the air bags inflate rapidly, filling with non-toxic nitrogen gas in a fraction of a second. Immediately after inflation, the air bags deflate by releasing the nitrogen gas through vent holes. The whole process takes place in a matter of seconds.

R WARNING

Air bag system components get hot after inflation. Do not touch them after inflation.



Inflated driver side supplemental air bag

Safety Restraints



Inflated passenger side supplemental air bag

R WARNING

If the air bag is inflated, THE AIR BAG WILL NOT FUNCTION AGAIN AND MUST BE REPLACED IMMEDIATELY. If the air bag is not replaced, the unrepaired area will increase the risk of injury in a collision.

To ensure that the air bag system will operate as intended in a crash, the system is equipped with a diagnostic module, which controls a readiness lamp and a warning tone. The diagnostic module monitors its own circuits, the air bag electrical system, the air bag readiness light, the air bag power, and the air bag inflators.

The air bag system uses a readiness light on the instrument cluster and a tone to indicate the condition of the system. When you turn the ignition key to the ON position, this light will illuminate for approximately six (6) seconds and then turn off. This indicates that the system is operating normally. NOTE: Maintenance of the air bag system is not required.

A problem with the system is indicated by one or more of the following:

- the readiness light will either flash or stay lit,
- or it will not light immediately after ignition is turned on,
- or a group of five beeps will be heard. The tone pattern will repeat periodically until the problem and light are repaired.

If any of these things happen, have the air bag system serviced at your Ford or Lincoln-Mercury dealer immediately. Unless serviced, the air bag supplemental restraint system may not function properly in the event of a collision.

R WARNING

Do not attempt to service, repair, or modify the Air Bag Supplemental Restraint System or its fuses. See your Ford or Lincoln-Mercury dealer.
--

Disposal of supplemental air bags or supplemental air bag equipped vehicles

For disposal of air bags or air bag equipped vehicles, see your local Ford or Lincoln-Mercury dealer. Air bags **MUST** be disposed of by qualified personnel.

Safety Restraints

Safety Restraints for Children

In the U.S. and Canada, you are required by law to use safety restraints for children. If small children ride in your vehicle — this generally includes children who are four years old or younger and who weigh 40 pounds (18 kg) or less — you must put them in safety seats that are made specially for children. Safety belts alone do not provide maximum protection for these children. Check your local and state laws for specific requirements.

R WARNING

Never let a passenger hold a child on his or her lap while the vehicle is moving. The passenger cannot protect the child from injury in a collision.

R WARNING

To prevent the risk of injury, make sure children sit where they can be properly restrained.

R WARNING

It is extremely dangerous to ride in a cargo area, inside or outside of a vehicle. In a collision, people riding in these areas are more likely to be seriously injured or killed. Do not allow people to ride in any area of your vehicle that is not equipped with seats and safety belts. Be sure everyone in your vehicle is in a seat and using a safety belt properly.

R WARNING

Whenever possible, put children in one of the rear seats in your vehicle. Accident statistics indicate that children are safer when properly restrained in the rear seats than in the front seats.

R WARNING

Carefully follow all of the manufacturer's instructions included with the safety seat you put in your vehicle. If you do not install and use the safety seat properly, the child may be injured in a sudden stop or collision.

R WARNING

Safety belts and seats can become hot in a vehicle that has been closed up in sunny weather; they could burn a small child. Check seat covers and buckles before you place a child anywhere near them.

R WARNING

Do not leave children, unreliable adults, or pets unattended in your vehicle.

Safety Seats for Children

Use a safety seat that is recommended for the size and weight of the child. Always follow the safety seat manufacturer's instructions when installing and using the safety seat.

Ford recommends the use of a child safety seat having a top tether strap. Install the child safety seat in a seating position which is capable of providing a tether anchorage. For more information on top tether straps see *Attaching Safety Seats With Tether Straps* in this chapter.

Safety Restraints

When installing a child safety seat, be sure to use the correct safety belt buckle for that seating position, and make sure the tongue is securely fastened in the buckle. For a shoulder/lap belt combination with a sliding tongue, make sure the retractor is in the automatic locking mode.

All child restraint systems are designed to be secured in vehicle seats by lap belts or by the lap portion of a lap-shoulder belt.

R WARNING

REAR-FACING INFANT SEATS SHOULD NEVER BE USED IN THE FRONT SEAT. REAR-FACING INFANT SEATS MUST ALWAYS BE PLACED IN THE REAR SEAT. Failure to follow these instructions could result in serious injury.

R WARNING

If you do not properly secure the safety seat, the child occupying the seat may be injured during a collision or sudden stop. An unsecured safety seat could also injure other passengers.

R WARNING

Carefully follow all of the manufacturer's instructions included with the safety seat you put in your vehicle. If you do not install and use the safety seat properly, the child may be injured in a sudden stop or collision.

The passenger side quick-release second row bucket seat is adjustable along a track and may be adjusted very close to the front passenger seat to allow easier entry and exit to third row seats.

R WARNING

The quick-release seat must be adjusted to the rearmost position when using an untethered forward-facing child safety seat.

R WARNING

The third row seat must be adjusted to the rearmost position when using an untethered forward facing child safety seat.

R WARNING

Always keep the buckle release button pointing upward and away from the child seat, with the tongue between the child seat and the release button as shown in the following illustration.

Safety Restraints

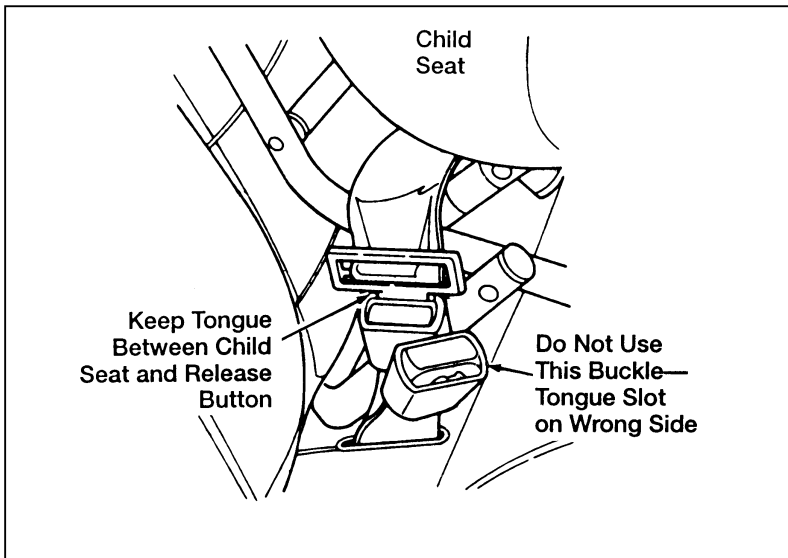

Safety belt buckle placement for child seats

Using the Automatic Locking Mode Retractor to Secure a Child Safety Seat

Your vehicle is equipped with a dual locking mode retractor on the shoulder belt portion of the combination lap/shoulder safety belt for the front passenger seat and rear outer seats. The automatic locking mode **must be used** when installing a child seat or infant carrier in the front passenger seat or rear outer seats.

R WARNING

Never install a rear-facing child seat or infant carrier in the right front passenger seat.

To install a child safety seat or infant carrier, follow these steps:

1. Position the child seat or infant carrier in the vehicle seat. If you are using the moveable third row seat in the third row position, the passenger side second row bucket seat, or the front passenger seat, slide the seat to the rearmost position.
2. Follow the child seat or infant carrier manufacturer's instructions. Route the safety belt through the child seat or infant carrier and insert the safety belt tongue into the buckle until you hear and feel the latch engage. Be sure to follow the child safety seat manufacturer's instructions for belt routing.

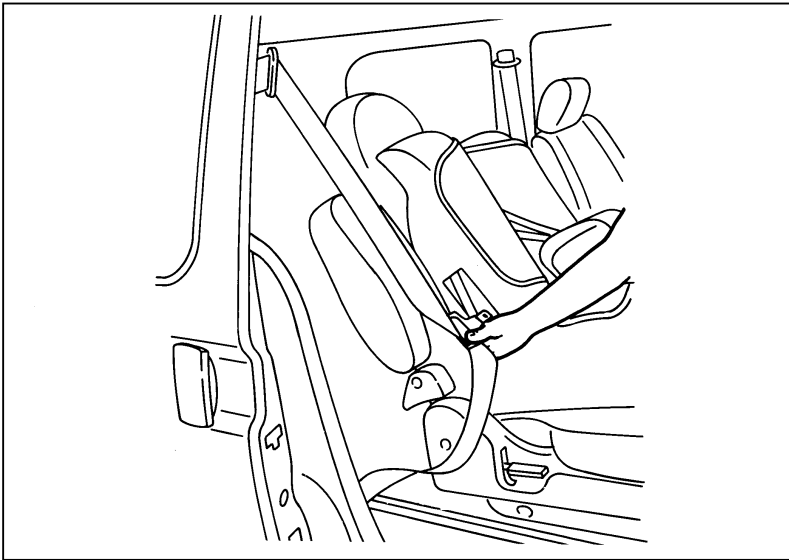

Routing the safety belt tongue through the child seat

3. Pull on the belt until all of the stored belt is out of the retractor and a click is heard.

Safety Restraints

4. Allow the belt to retract. A clicking sound will be heard as the belt retracts. This indicates that the retractor is in the automatic locking mode.
5. Pull up on the shoulder belt to remove slack in the belt while you push down on the child seat.

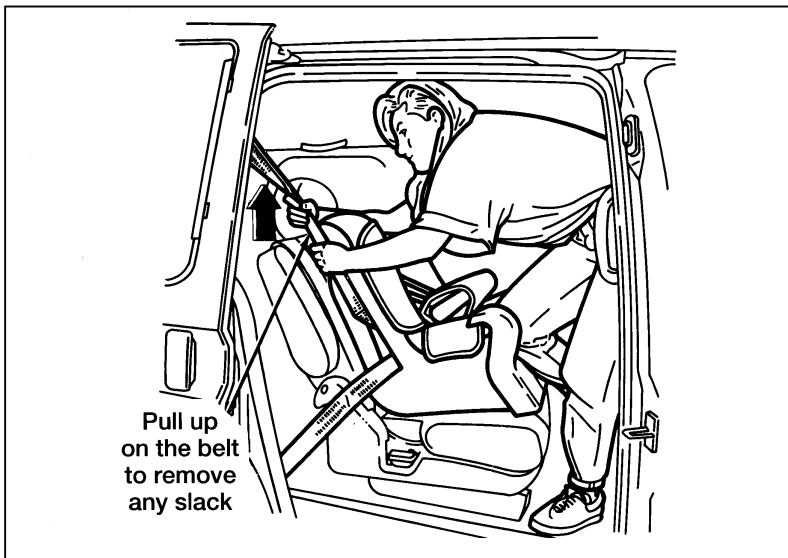

Removing slack from the safety belt

-
6. Before placing the child in the child seat or infant carrier, use force to tilt the seat from side to side, and tug it forward to make sure that the seat is securely held in place.

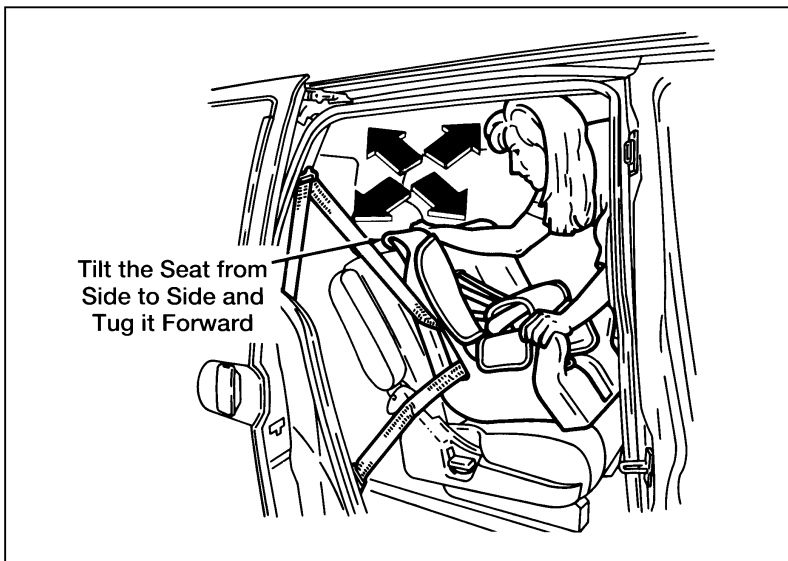

Testing the security of the child seat

7. Check that the retractor is in the automatic locking mode. Try to pull more belt out of the retractor. If you cannot, the belt is in the automatic locking mode.
8. Check to make sure the child seat or infant carrier is properly secured prior to each use. If the safety belt is not locked, repeat steps 3 through 6.

NOTE: When the lap/shoulder belt is unbuckled and allowed to retract completely, the retractor will switch to the vehicle sensitive (emergency) locking mode.

Safety Restraints

The automatic locking mode is activated whenever all of the belt webbing is pulled out of the retractor.

While in this mode, the belt will retract or tighten but cannot be pulled back out to obtain more length. To disengage the automatic locking mode, unbuckle the belt and allow the webbing to retract fully.

Attaching Safety Seats With Tether Straps

Some manufacturers make safety seats that include a tether strap that goes over the back of the vehicle seat and attaches to an anchoring point. Other manufacturers offer the tether strap as an accessory. Contact the manufacturer of your child safety seat for information about ordering a tether strap.

All vehicles built for sale in Canada include tether anchor hardware for use with Canadian child safety seats. The tether anchor hardware is located in the tire changing tool kit. Additional tether anchor hardware can be obtained at no charge from any Ford or Lincoln-Mercury dealer.

Vehicles built for sale in the USA **do not** include tether anchor hardware, but it can be obtained at no charge from any Ford or Lincoln-Mercury dealer (Part number F3XY-12613D20-A).

The chart below specifies, for each seat type and position, where the tether strap must be attached to the vehicle and the section containing the appropriate instructions for tethering.

Seat Type/Position	Tether to . . .	Reference Section
3-passenger/3rd row position	Floor anchor directly behind child seat position	<i>Tethering to floor anchor</i>
2-passenger bench or bucket/2nd row child seat position	Tongue of 3rd row belt directly behind child seat position	<i>Tethering to lap/shoulder belt tongue</i>
3-passenger/2nd row – Outboard – Center	Tongue of 3rd row belt directly behind child seat position CANNOT BE TETHERED	<i>Tethering to lap/shoulder belt tongue</i> —
Bucket/1st row	Tongue of 2nd row belt behind child seat position	<i>Tethering to lap/shoulder belt tongue</i>

Safety Restraints

Tethering to floor anchor

Ford recommends placing tethered safety seats in a rear seating position with the tether strap attached to the tether anchoring point as shown in the following illustration.

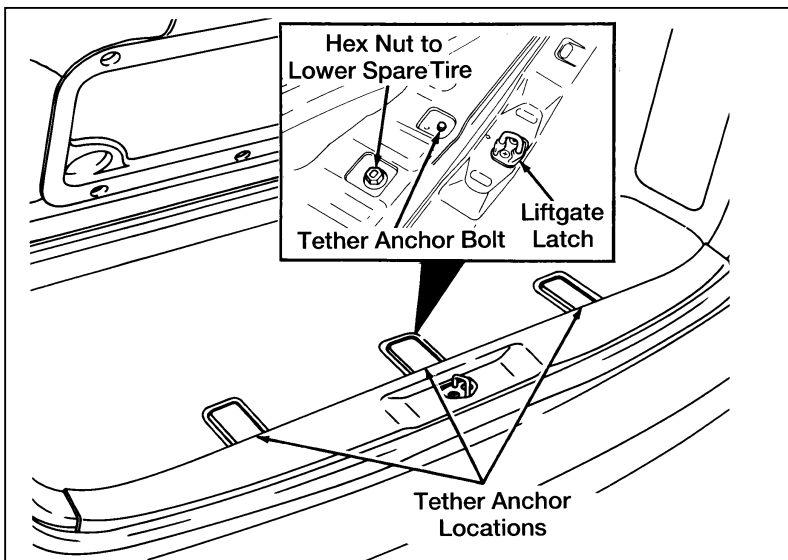

Tether anchor point locations

To gain access to the anchoring bolt, cut through the plastic along the U-shaped tether location outlines on the carpet of the luggage area. Remove the bolt that is currently in the anchor location. The tether anchor hardware has been preassembled. To attach it, orient the tab in the bracket toward the front of the vehicle and securely tighten the bolt. Follow the child safety seat directions for attaching the tether strap to the anchor bracket.

R WARNING

Only use the tether attachment hole locations shown in the illustrations. The tether anchor may not perform properly if the wrong mounting location is used.

R WARNING

Failure to follow these precautions could increase the chance of injury in an accident.

R WARNING

If the anchor bolt(s) is ever removed, the hole(s) in the floor must be sealed to prevent the possibility of exhaust fumes entering the passenger compartment.

Tethering to lap/shoulder belt tongue

To attach a tether strap to a lap/shoulder belt:

1. Route the tether strap under the headrest and between the headrest supports.
2. Hook the tether strap hook into the large hole at the end of the tongue of the lap/shoulder belt directly behind the child seat position.
3. Adjust the tether strap length until the hook is about one foot behind the seatback.
4. Pull the shoulder belt until all of the belt is fully extended and a click is heard. At this time the belt is in automatic locking mode (child restraint mode).
5. Let the retractor wind up the slack from the lap/shoulder belt. A clicking sound should be heard as the belt retracts, indicating that the retractor is in the automatic locking mode. Tighten the tether strap to remove any slack.

Safety Restraints

6. Before placing a child in the child restraint, use force to tilt the child restraint from side to side and tug it forward to make sure it is securely held in place.
7. Check that the retractor is in automatic locking mode by trying to pull more belt out of the retractor. If you cannot pull any more belt webbing out of the retractor, the belt is in automatic locking mode.
8. Check to make sure the child restraint is properly secured prior to each use. If the belt is not locked, repeat steps 4 through 7.

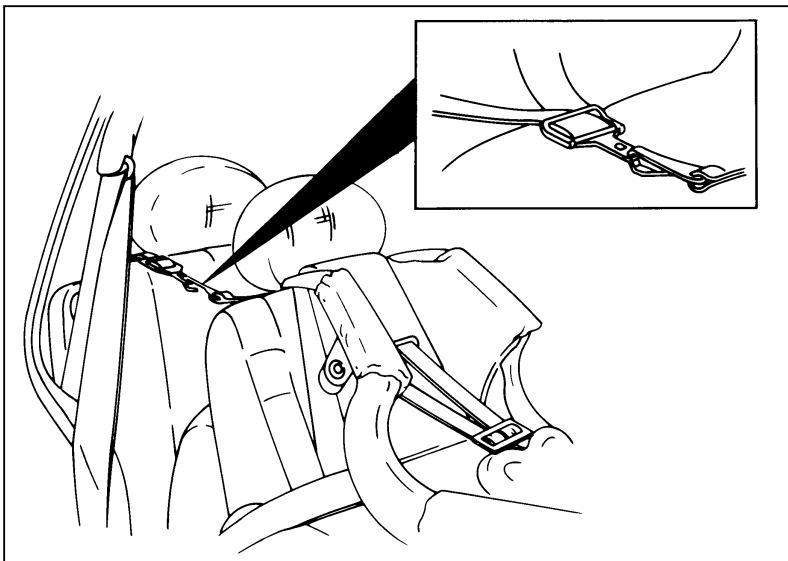

Safety Belts for Children

Children who are too large for child safety seats should always wear safety belts. (See instructions with your child seat, or contact its manufacturer, to determine maximum size of a child that will fit safely in the safety seat.)

R WARNING

If safety belts are not properly worn and adjusted as described, the risk of serious injury to the child in a collision will be much greater.
--

R WARNING

If the shoulder belt portion of one of the lap/shoulder belts can be positioned so that it does not cross or rest in front of the child's face or neck, the child should wear the lap/shoulder belt. Moving the child closer to the center of the vehicle may help provide a good shoulder belt fit.

To improve the fit of lap and shoulder belts on children who have outgrown child safety seats, Ford recommends use of a belt-positioning booster seat that is labelled as conforming to all Federal motor vehicle safety standards. Belt-positioning booster seats raise the child and provide a shorter, firmer seating cushion that encourages safer seating posture and better fit of lap and shoulder belts on the child. A belt-positioning booster should be used if the shoulder belt rests in front of the child's face or neck, or if the lap belt does not fit snugly on both thighs, or if the thighs are too short to let the child sit all the way back on the seat cushion when the lower legs hang over the edge of the seat cushion. You may wish to discuss the specific needs of your child with your pediatrician.

Safety Restraints

R WARNING

Do not use a belt-positioning booster with a lap-only belt.
--

R WARNING

The lap belt portion of combination lap/shoulder belts should always be worn snugly and below the hips, touching the child's thighs.

R WARNING

Children should always ride with the seatback in the fully upright position. When the seatback is not fully upright, there is a greater risk that the child will slide under the safety belt and be seriously injured in a collision.
--

Built-In Child Seats (If equipped)

The optional second row bench seat includes two built-in child seats. These child restraints are to be used only by children who:

■ are at least one year old

AND

■ weigh between 9 and 27 kilograms (20 and 60 pounds)

AND

■ whose shoulders are below the shoulder harness slots

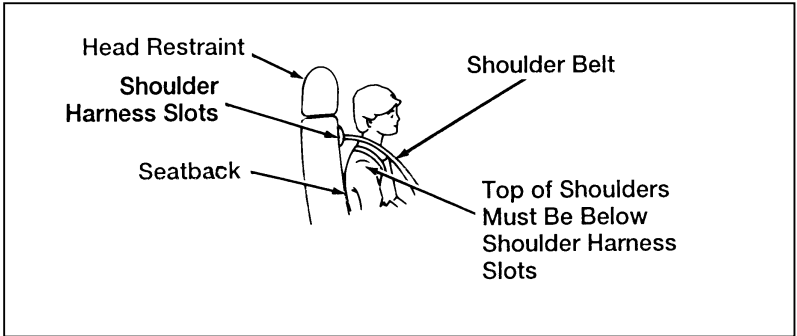

Children not meeting these requirements should be restrained in an approved aftermarket child safety seat. Follow the specific manufacturer's instructions for weight and height restrictions.

Children must be properly buckled before riding in the vehicle. It is the law in every state and province. These child seats conform to all Federal/Canadian motor vehicle safety standards.

R WARNING
The second row seatback must be fully locked before operating the child restraint system. Check the position of the seatback release lever.

Safety Restraints

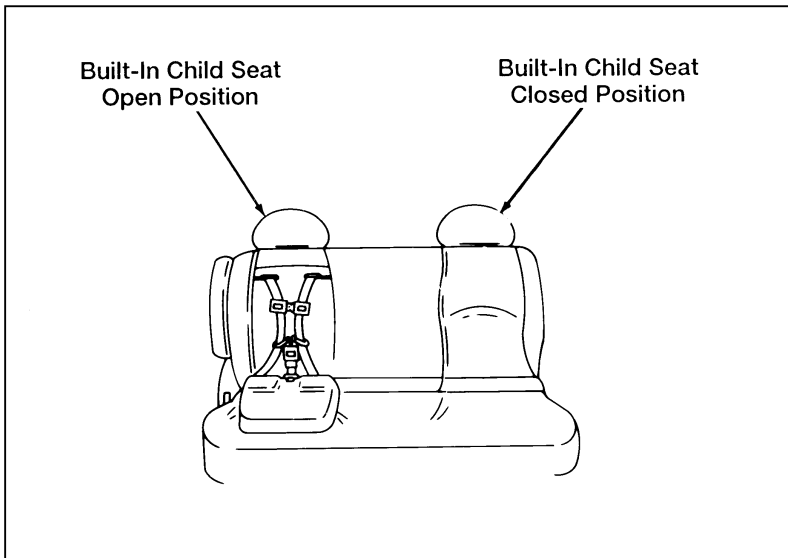

Second row bench built-in child seats

Built-In Child Seat Retractors

The retractor will switch from the emergency locking mode to the automatic locking mode when the right shoulder belt is pulled all the way out. The retractor will switch back to emergency locking mode when the belts are unbuckled and the shoulder belts retract completely.

The automatic locking mode must be used to hold small children in position, particularly sleeping children and those who may try to squirm out of the belts. The emergency locking mode is used while buckling the belts.

Always adjust the lap and shoulder harness belts provided with this child seat snugly around your child.

R WARNING

The child seats' metal and plastic parts can become very hot when left in the sun. These can cause burns to unprotected skin.

R WARNING

Failure to follow all of the instructions on the use of this child restraint system can result in your child striking the vehicle's interior during a sudden stop or crash.

How to Use the Built-In Child Seat

Read the following procedures and all of the labels on the built-in child seat before using the seat.

R WARNING

Never use the Built-In Child Seat as a booster cushion with the adult safety belts. A child using the adult belts could slide forward and out from under the safety belts.

1. Hold the tab from the lower outboard side of the child seat and lower the cushion completely.

Safety Restraints

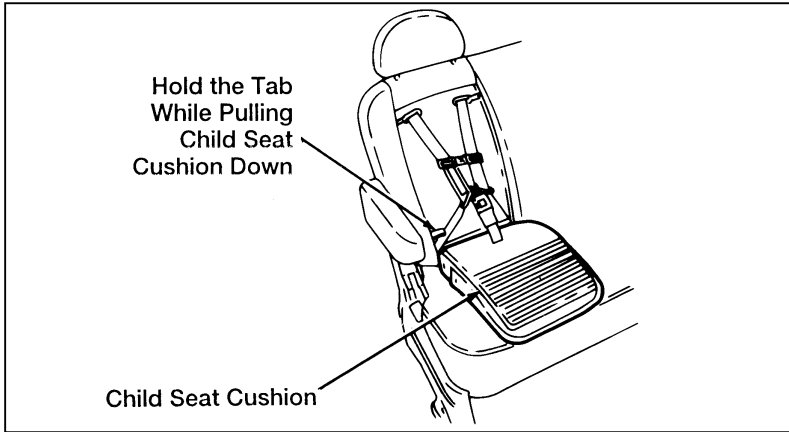

-
2. If connected, unbuckle the two safety belt tongues. Also detach the chest clip.

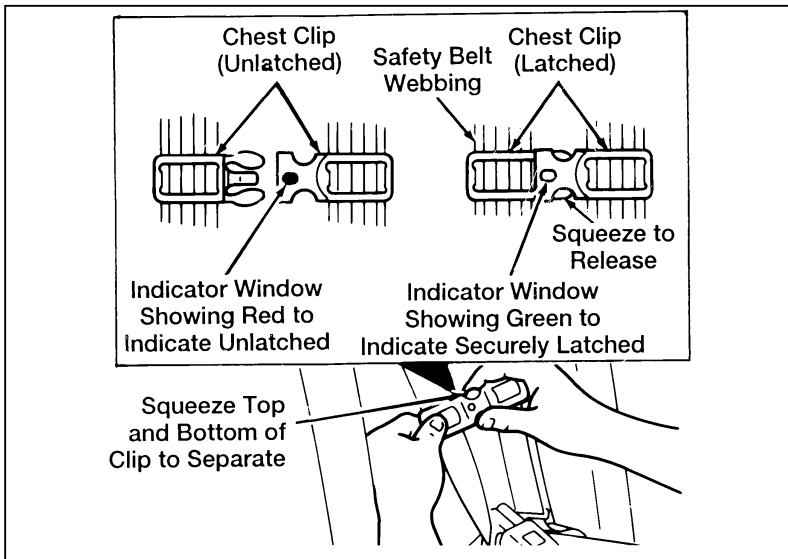

Safety Restraints

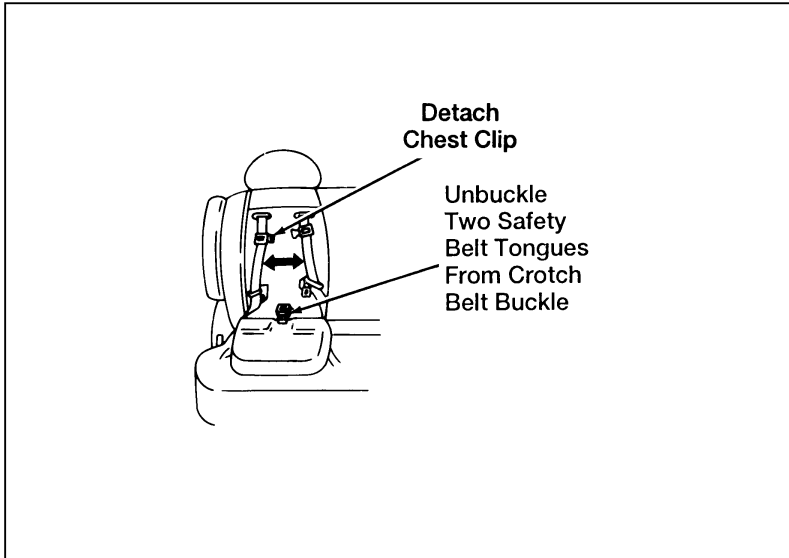

-
3. Place the child in the built-in child seat. Position the crotch belt buckle between the child's legs.

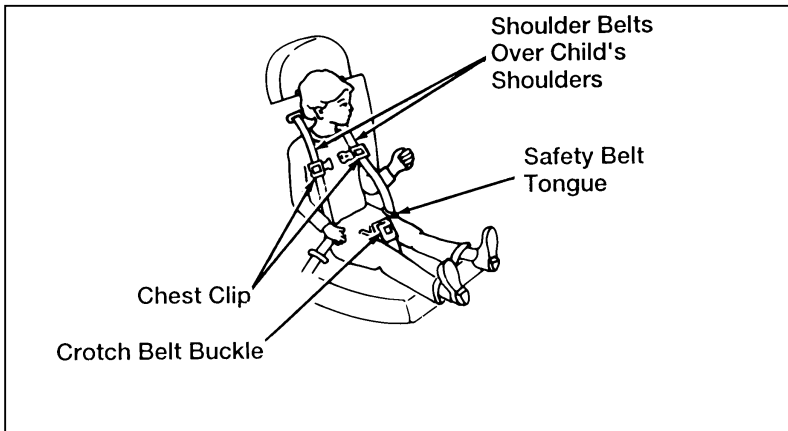

Safety Restraints

4. Place the left shoulder belt harness over the child's left shoulder. Insert the left shoulder harness tongue into the left side of the belt buckle. Confirm that the left shoulder harness tongue indicator is green.

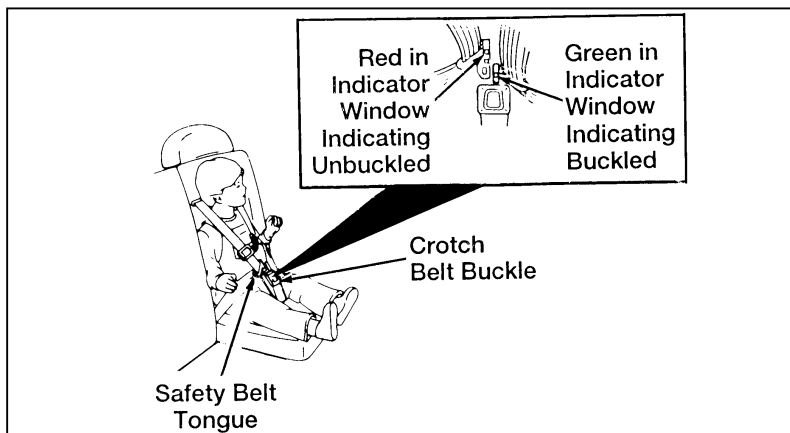

5. Place the right shoulder belt harness over the child's right shoulder. Insert the right shoulder harness tongue into the right side of the belt buckle. Confirm that the right shoulder harness tongue indicator is green.
6. Fasten the two halves of the chest clip below the child's shoulders. Adjust the clip to comfortably hold the shoulder belts in place on the child's chest. Confirm that the chest clip indicator is green.

NOTE: The chest clip can be easily pulled apart and is designed to separate during a collision.

-
7. Pull the right shoulder belt fully out to put the retractor into the locking mode. At this time, the shoulder belts are in an automatic locking mode. Allow the safety belts to tighten snugly against the child's shoulders. The belt will automatically lock and cannot be pulled out.

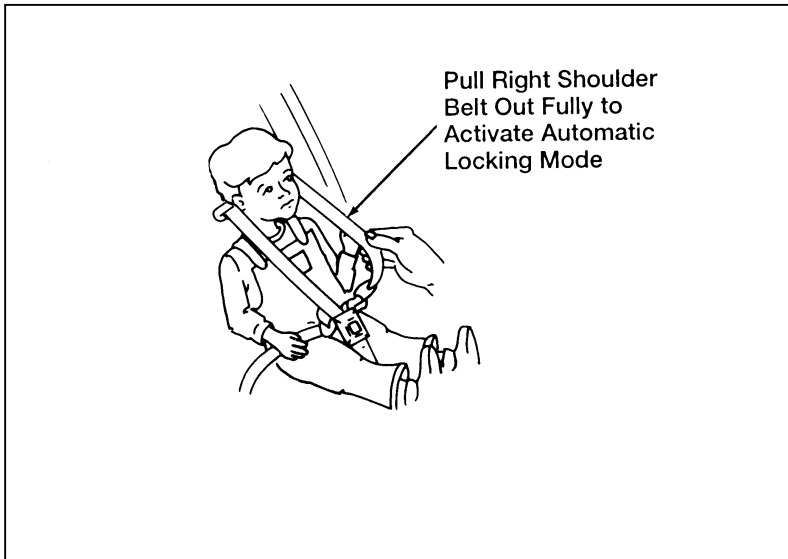

8. If the shoulder belts are too tight, unlatch the chest clip and unbuckle the child from the built-in child seat. Allow the shoulder belts to retract fully. Repeat the procedure from step 3 through step 7.

Safety Restraints

Removing the child from the built-in child seat

1. Open the chest clip by squeezing together the release tabs on the top and bottom edges of the center of the chest clip. Pull the two halves apart.
2. Press the release button on the crotch belt buckle.
3. Slide the shoulder belts off the child's shoulders. Remove the child from the built-in child seat.
4. Confirm that the shoulder belts are fully retracted and resting inside the built-in child seat recess. It is unnecessary to reconnect the shoulder harness and belt buckle prior to storing the built-in child seat.

-
5. While holding the cushion release strap, rotate the cushion upward until it fits flush with the second row seatback pad.

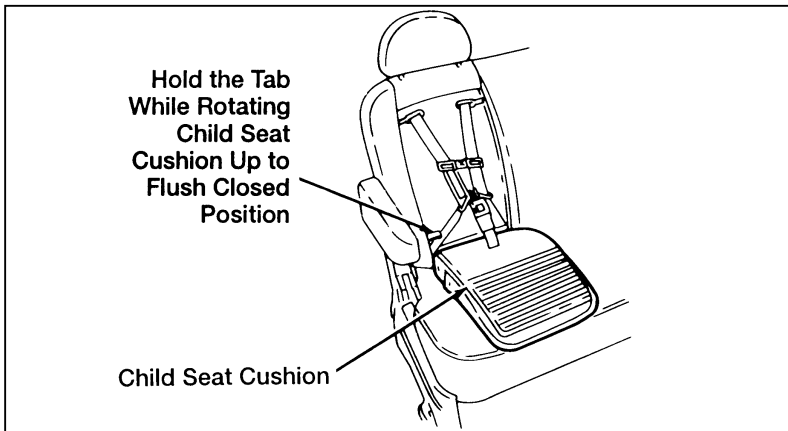

6. Confirm that the built-in child seat is locked in the stowed position by grasping the safety seat cushion and attempting to lower it without pulling the cushion release strap.
7. If the built-in child seat is not locked in the stowed position, repeat steps 4 through 6.

Starting Your Villager

Ignition

Understanding the Positions of the Ignition

Your vehicle's ignition has four positions. They are:

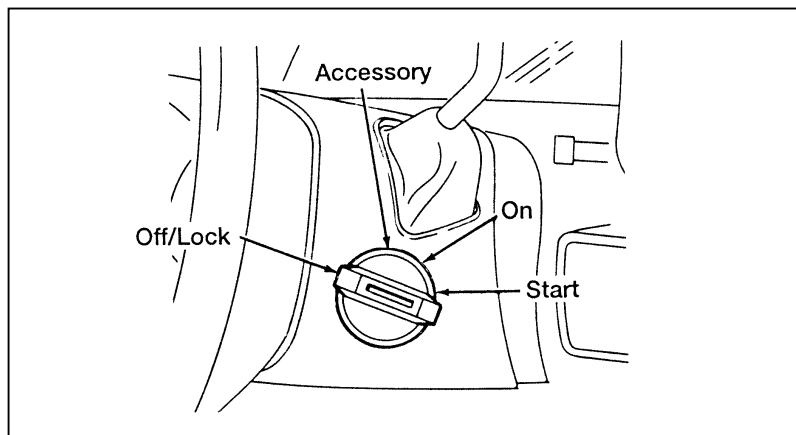

The ignition positions

ON allows you to test your vehicle's warning lights to make sure they work before you start the engine. The key returns to the ON position once the engine is started and remains in this position while the engine runs.

START cranks the engine. Release the key once the engine starts so that you don't damage the starter. The key should return to the ON position when you release it.

OFF/LOCK allows you to shut off the engine and all accessories and locks the gearshift lever. Removing the key then locks the steering wheel.

ACCESSORY allows you to operate some of your vehicle's electrical accessories while the engine is not running. For example, you can use ACCESSORY to turn on the radio, windshield wipers, or operate the cigarette lighter without starting the engine.

Ignition Key Chime

The chime will sound if you open the driver's door while the key is in the ignition. Never leave your vehicle unattended with the key in the ignition.

Removing the Key From the Ignition

OFF/LOCK is the only position that allows you to remove the key from the ignition. The LOCK feature helps to protect your vehicle from theft, because it also locks the steering wheel and the gearshift lever when the key is removed.

If your key is stuck in the LOCK position, and you are unable to turn it, move your steering wheel left or right until the key turns freely.

To remove your key from the ignition:

1. Put the gearshift lever in P (Park).
2. Set the parking brake fully.
3. Turn the ignition key to LOCK.
4. Remove the key.

 WARNING
--

<p>When you leave your vehicle, place the gearshift lever in P (Park). Set the parking brake fully, and shut off the engine. Never park your vehicle in N (Neutral). If you do not take these precautions, your vehicle may move suddenly and injure someone.</p>
--

Starting Your Villager

WARNING

Do not leave children, unreliable adults, or pets alone in your vehicle. They could accidentally injure themselves or others through inadvertent operation of the vehicle. Further, on hot, sunny days, temperatures in a closed vehicle could quickly become high enough to cause severe and possibly fatal injuries to people as well as animals.

Fuel-Injected Engines

When starting a fuel-injected engine, **the most important thing to remember is to avoid pressing down on the accelerator before or during starting.** Only use the accelerator when you have problems getting your vehicle started. See *Starting Your Engine* in this chapter for details about when to use the accelerator while you start your vehicle.

Starting Your Vehicle

Preparing to Start Your Vehicle

WARNING

Do not start your vehicle in a closed garage or other enclosed area. Never sit in a stopped vehicle for more than a short period of time with the engine running. Exhaust fumes are toxic. See *Guarding Against Exhaust Fumes* in this chapter for more instructions.

Before you start your vehicle, always:

1. Make sure you and all your passengers buckle your safety belts. See *Safety belts* in the Index for more details.
2. Make sure the headlamps and other accessories are turned off when starting.

-
3. Make sure that the gearshift is in P (Park) and the parking brake is set before you turn the key.
 4. Test the warning lights on the instrument cluster to make sure they work. Refer to the *Warning Lights and Gauges* chapter.

Starting Your Engine

To start your engine:

1. Follow the steps under *Preparing to Start Your Vehicle* at the beginning of this section.
2. Keep your foot on the brake pedal and turn the ignition key to ON.
3. DO NOT depress the accelerator pedal when starting your engine. DO NOT use the accelerator while the vehicle is parked.
4. Turn the key to the START position (cranking) until the engine starts. Allow the key to return to the ON position after the engine has started.

If you have difficulty in turning the key, rotate the steering wheel slightly because it may be binding.

For a cold engine:

- At temperatures **10°F (-12°C) and below**: If the engine does not start in **fifteen (15) seconds** on the first try, turn the key to OFF, wait approximately ten (10) seconds so you do not flood the engine, then try again.
- At temperatures **above 10°F (-12°C)**: If the engine does not start in **five (5) seconds** on the first try, turn the key to OFF, wait approximately ten (10) seconds so you do not flood the engine, then try again.

Starting Your Villager

For a warm engine:

- Do not hold the key in the START position for more than **five (5) seconds** at a time. If the engine does not start within five (5) seconds on the first try, turn the key to the OFF position. Wait a few seconds after the starter stops, then try again.

Whenever you start your vehicle, release the key as soon as the engine starts. Excessive cranking could damage the starter or flood the engine.

After you start the engine, let it idle for a few seconds. **Keep your foot on the brake pedal** and release the parking brake. Put the gearshift lever in gear, slowly release the brake pedal and drive away in the normal manner.

NOTE: Your vehicle has an interlock that prevents you from shifting out of Park (P) unless your foot is on the brake pedal.

If the engine does not start after two attempts:

1. Turn the ignition key to the OFF position.
2. Press the accelerator all the way to the floor and hold it.
3. Turn the ignition key to the START position.
4. Release the ignition key when the engine starts.
5. Release the accelerator gradually as the engine speeds up. Then drive away in the normal manner.

If the engine still does not start, the fuel pump shut-off switch may have been triggered. For directions on how to reset the switch see *Fuel Pump Shut-Off Switch* later in this chapter.

A computer system controls the engine's idle speed. When you start your vehicle, the engine's idle speed normally runs high. These faster engine speeds will make your vehicle move slightly faster than its normal idle speed. It should, however, slow down after a short time. If it does not, have the idle speed checked.

If the engine idle speed does not slow down automatically, do not allow your vehicle to idle for more than 10 minutes. Have the vehicle checked.

 **WARNING**

Extended idling at high engine speeds can produce very high temperatures in the engine and exhaust system, creating the risk of fire or other damage.

 **WARNING**

Do not park, idle, or drive your vehicle in dry grass or other dry ground cover. The emission system heats up the engine compartment and exhaust system, which can start a fire.

If you consistently start your vehicle in subzero temperatures, use an engine block heater (if your vehicle has this option).

Engine Block Heater (If equipped)

Engine block heaters are strongly recommended if you live in a region where temperatures reach -10°F (-23°C) or below. An engine block heater warms the engine coolant, which improves starting, warms up the engine faster, and allows the heater-defrost system to respond more quickly.

 **WARNING**

To prevent electrical shock, do not use your heater with ungrounded electrical systems or two-pronged (cheater) adapters.

Starting Your Villager

For best results, plug the heater in at least three hours before you start your vehicle. Using the heater for longer than three hours will not damage the engine, so you can leave it plugged in all night to start your vehicle the following morning.

What To Do If The Engine Does Not Start

Fuel Pump Shut-Off Switch

If the engine cranks but does not start or does not start after a collision, the fuel pump shut-off switch may have been triggered. The shut-off switch is a device intended to stop the fuel pump when your vehicle has been involved in a substantial jolt.

Once the shut-off switch is triggered, you must reset the switch by hand before you can start your vehicle.

The fuel pump shut-off switch reset button is located below the hood release handle.

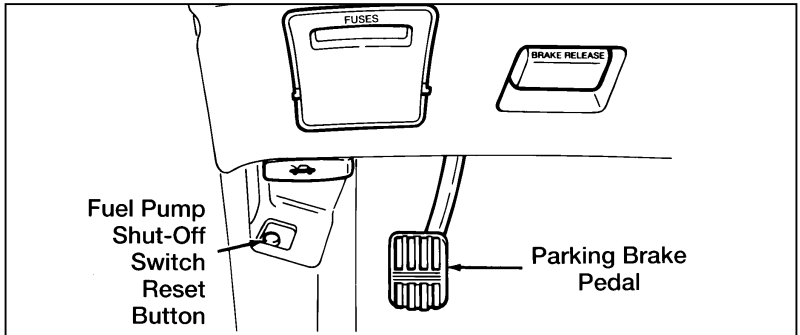

Fuel pump shut-off switch reset button location

⚠ WARNING

If you see or smell fuel, do not reset the switch or try to start your vehicle. Have all the passengers get out of the vehicle and call the local fire department or a towing service.

If your engine cranks, but does not start after a collision:

1. Turn the key in the ignition to the OFF position.
2. Check under the vehicle for leaking fuel.
3. If you do not see or smell fuel, push the fuel pump shut-off reset button down. If the red button is already set, you may have a different mechanical or electrical problem.
4. Turn the ignition key to the ON position for a few seconds, then turn it to the OFF position.
5. Check under the vehicle again for leaking fuel. If you see or smell fuel, do not start your vehicle again. If there is no fuel, you can try to start your vehicle again.
6. Check all vehicle warning lights before driving your vehicle.

Guarding Against Exhaust Fumes

Carbon monoxide, although colorless and odorless, is present in exhaust fumes. Take precautions to avoid its dangerous effects.

⚠ WARNING

Never let your vehicle idle in an enclosed area, and do not sit in a parked vehicle, (with the engine running) for more than a short period of time. Exhaust fumes, particularly carbon monoxide, might build up. These fumes are harmful and could kill you.

Starting Your Villager

WARNING

If you ever smell exhaust fumes of any kind inside your vehicle, have your dealer inspect and fix your vehicle immediately. Do not drive if you smell exhaust fumes. These fumes are harmful and could kill you.

Have the exhaust and body ventilation systems checked by a qualified technician whenever:

- your vehicle is raised for service
- the sound of the exhaust system changes
- your vehicle has been damaged in an accident

Improve your ventilation by keeping all air intake vents clear of snow, leaves, and other objects.

If the engine is idling while you are stopped in an open area for long periods of time, open the windows at least one inch (2.5 cm). Also, adjust the heating or air conditioning to bring in outside air.

Read the section *Climate Control Systems* for instructions on bringing fresh outside air into your vehicle. Refer to the Index.

Warning Lights and Gauges

Warning Lights and Gauges

The instrument panel (dashboard) on your vehicle is divided into several different sections. The illustrations on the following pages show the major parts of the instrument panel described in this chapter. Some items shown may not be on all vehicles.

To clean the lenses on your instrument panel, use Ford Glass Cleaner and a soft cloth. Never use paper towels or abrasive cleaners; they can scratch the lenses.

In your vehicle, the warning lights and gauges are grouped together on the instrument panel. We call this grouping a cluster. Your vehicle may have a mechanical cluster or an electronic cluster.

If you are not sure which cluster your vehicle has, check the diagrams on the following pages.

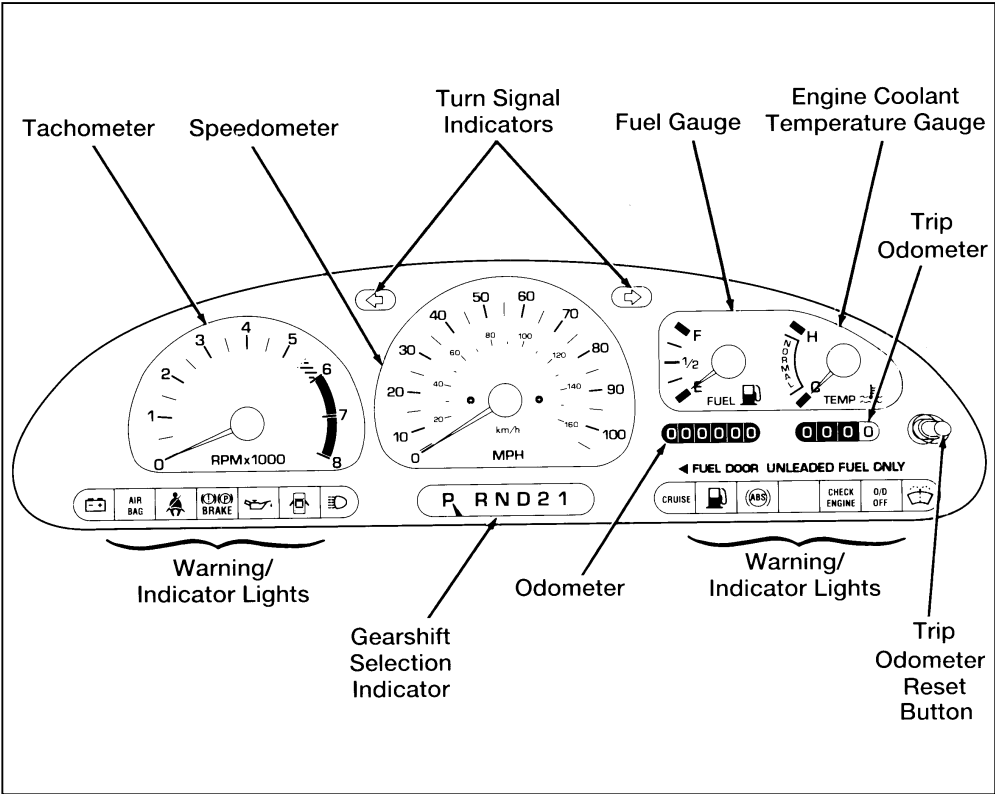

Warning Lights and Gauges

The following warning lights and gauges are on the mechanical cluster. All of the warning lights and gauges alert you to possible problems with your vehicle. Some of the lights listed are optional. The following section explains what each of these indicators means.

Indicator Lights and Chimes

Brake System Warning Light

The warning light for the brakes can show two things — that the parking brake is not fully released, or that the brake fluid level is low in the master cylinder reservoir. If the fluid level is low, the brake system should be checked by your dealer or a qualified service technician.

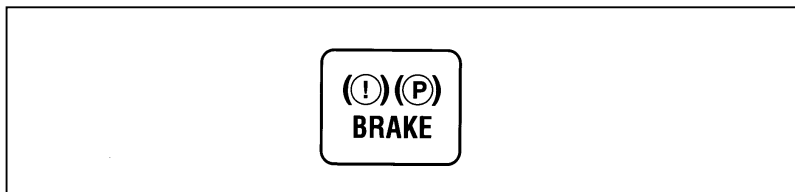

Brake system and parking brake light

The BRAKE light normally comes on when you turn the ignition key to the ON position to verify that the indicator bulb is working. If the light stays on or comes on when the engine is running and after you have released the parking brake fully, have the hydraulic brake system serviced.

WARNING

The BRAKE light indicates that the brakes may not be working properly. Have the brakes checked immediately.

Anti-Lock Brake System Warning Light (If Equipped)

To check the anti-lock brake warning light, turn the ignition key to the ON position. The ABS warning light should glow momentarily.

NOTE: If it does not glow at all or stays on for a long time, have your vehicle's electrical system checked immediately.

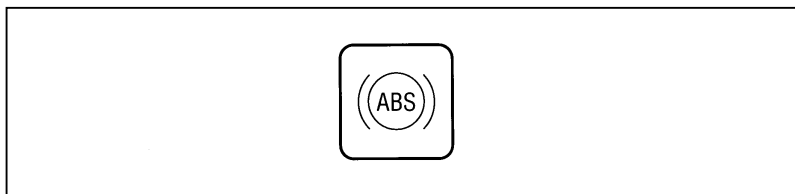

Anti-lock brake system warning light

WARNING

If the anti-lock brake system warning light remains on or comes on while driving, have the braking system checked by a qualified service technician as soon as possible.

NOTE: If a fault occurs in the anti-lock system, and the brake warning light is not lit, the anti-lock system is disabled but normal brake function remains operational.

Safety Belt Warning Light and Chime

This warning light and chime remind you to fasten your safety belt.

- If the safety belt is not buckled when the ignition is turned to the ON position, the chime will turn on for four (4) to eight (8) seconds and the light will remain on continuously, or until the safety belt is fastened.

Warning Lights and Gauges

- If the safety belt is buckled while the light is on and the chime is sounding, both the light and chime will turn off.
- If the safety belt is buckled before the ignition is turned to the ON position, the chime does not sound, and the warning light will not illuminate.



Safety belt warning light

Air Bag Readiness Light

The supplemental air bag system uses a readiness light to indicate the condition of the system. If the system is functioning properly, the light will stay on for about six (6) seconds when the ignition switch is turned to the ON position.

If there is a problem with the system, the readiness light may fail to illuminate, continue to flash, or remain on. If any of these conditions occur, have the system serviced as soon as possible. Unless the system is serviced, the supplemental air bag system may not function properly in the event of a collision.

A problem with the system is indicated by one or more of the following: the readiness light will either flash or stay lit, or it will not light, or a group of five beeps will be heard.

⚠ WARNING

If any of these things happen, even intermittently, have the air bag system serviced at your Ford or Lincoln-Mercury dealer immediately.

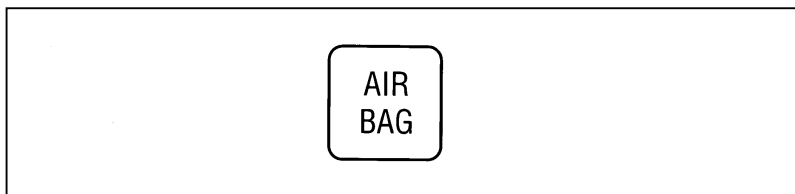

Supplemental air bag readiness light

Check Engine Warning Light

This light comes on when the electronic engine control system is not working properly. This is the computer that controls the operating conditions of the engine.

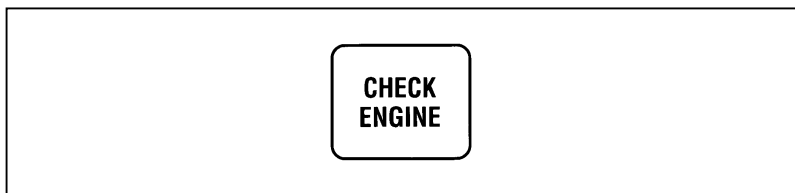

Check engine warning light

This light comes on briefly when you turn the ignition key to ON, but should turn off when the engine starts. If the light does not come on when you turn the ignition to ON or if it comes on and stays on when you are driving, have your vehicle serviced as soon as possible. This indicates a possible problem with one of the engine's emission control systems. You do not need to have your vehicle towed.

If the light turns on and off briefly while you are driving, it means that the condition is no longer present.

Warning Lights and Gauges

Charging System Light

This light, shown as a battery symbol on your cluster, indicates that your battery is not being charged and that you need to have the electrical system checked.

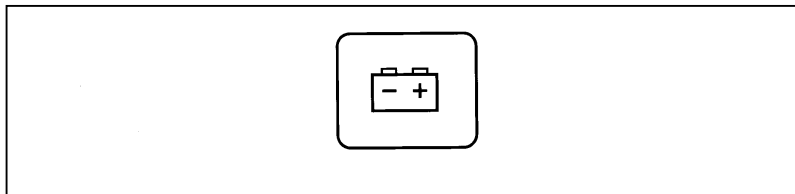

Charging system light

This light comes on every time you turn your ignition key to the ON or START position. The light should go off when the engine starts and the alternator begins to charge.

If the light stays on or comes on when the engine is running, have the electrical system checked as soon as possible.

Engine Oil Pressure Warning Light

The oil pressure light is represented by an oil can symbol. It indicates the engine's oil pressure, not oil level. However, if your engine's oil level is low, it could affect the oil pressure. The oil can symbol will flash if the oil pressure drops below the normal operating level. When you turn the key to the ON position, the light will illuminate.

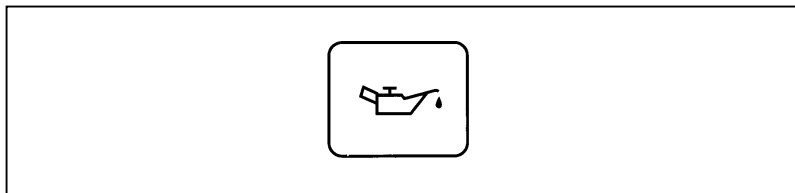

Oil pressure light

The light should turn off after a few seconds. If the light stays on or illuminates when the engine is running — you have lost oil pressure and continued operation will cause severe engine damage.

If you lose engine oil pressure:

1. Pull off the road as soon as safely possible.
2. Turn off the engine. If you do not stop the engine as soon as safely possible, severe engine damage could result.
3. Check the oil level following the instructions on checking and adding engine oil in this owner guide. (See *Engine oil* in the index.) Make sure your vehicle is on level ground.
4. If the level is low, add as much oil as necessary before you drive your vehicle again. Do not drive your vehicle if the oil pressure light is on, even if the oil level is correct. For more information about adding oil, see *Engine oil, checking and adding* in the Index.

Door Ajar Warning Light

If the ignition switch is in the ON position and any door or the liftgate is not completely closed, the light will illuminate.

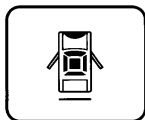

Door ajar warning light

Warning Lights and Gauges

Cruise Indicator Light

The CRUISE indicator light will illuminate when the speed control system is activated.

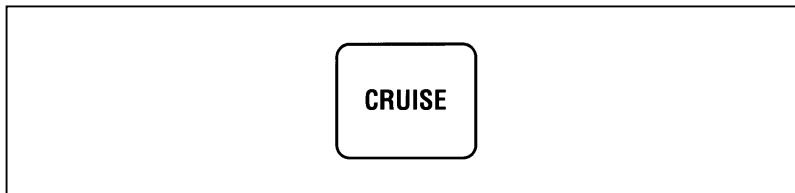

Cruise indicator light

Overdrive Off Indicator Light

If you choose to drive in the D (Drive) gear position instead of in **D** (Overdrive), you can use the OVERDRIVE OFF/ON button on the gearshift selector lever. When you drive with the vehicle in the Overdrive Off position, the O/D OFF indicator light will illuminate. The light also illuminates briefly when the key is turned to the ON position.

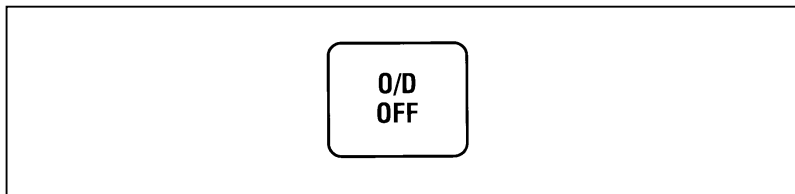

Overdrive off indicator light

If the light flashes for about 8 seconds when the ignition is turned to ON, it means the transaxle control unit received an improper signal the last time the vehicle was operated. It may be necessary to have your dealer check the transaxle.

Low Fuel Light

The low fuel light illuminates when the fuel sensor indicates approximately 1/8 of a tank. It will remain illuminated until the tank is filled with enough fuel to pass the 1/8 full level.



Low fuel light

Low Washer Fluid Light

The low washer fluid light will remain illuminated when the washer fluid sensor indicates that the washer fluid level is low.

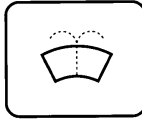

Low washer fluid light

Warning Lights and Gauges

High Beam Light

This light comes on when the headlamps are turned to high beam or when you flash the lights.

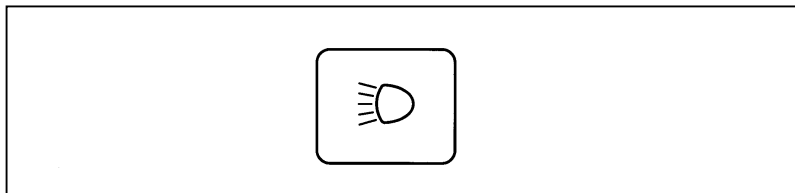

High beam light

“Headlamps On” Alert Chime

This chime will sound if you open the door while the headlamps or parking lamps are on.

Gauges

Fuel Gauge

The fuel gauge displays approximately how much fuel you have in the fuel tank. The fuel gauge indicator may vary slightly while the vehicle is in motion. This is the result of fuel movement within the tank. An accurate reading may be obtained when the vehicle is on smooth, level ground.

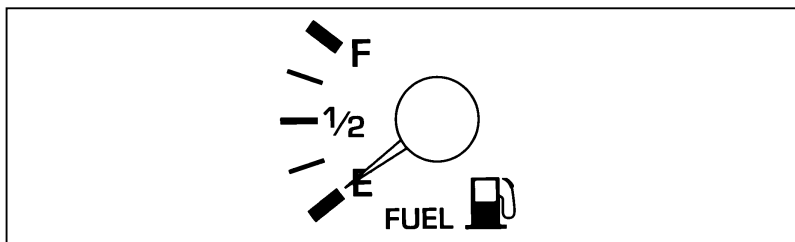

Fuel gauge

Engine Coolant Temperature Gauge

This gauge is accompanied by a thermometer symbol. It will show you the temperature of the engine coolant when the ignition is in the ON position.

As the engine warms up, the pointer will move to the NORMAL band. When you are driving in heavy traffic or experiencing stop-and-go conditions in hot weather, the pointer may move to the very top of the normal band.

Under any circumstances, if the pointer moves past the upper limit of the NORMAL band, the engine is overheating and engine damage may occur.

If your engine overheats:

1. Pull off the road as soon as it is safely possible.
2. Turn off the engine. If you do not stop the engine as soon as safely possible, severe engine damage could result.
3. Let the engine cool. **DO NOT REMOVE COOLANT SYSTEM FILL CAP UNTIL THE ENGINE IS COOL.**
4. Check the coolant level following the instructions on checking and adding coolant to your engine, see *Engine coolant* in the Index. If you do not follow these instructions, you or others could be injured.
5. Add as much coolant as your engine needs. If the engine continues to overheat, have the coolant system serviced.

Warning Lights and Gauges

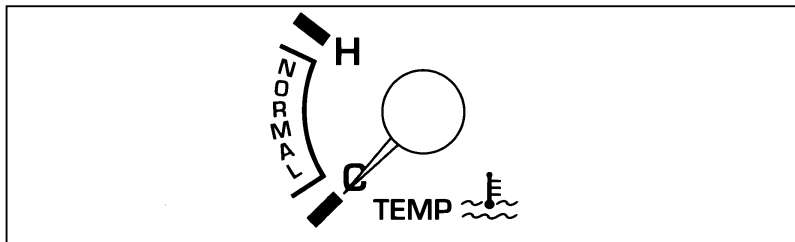

Engine coolant temperature gauge

Speedometer

The speedometer tells you how many miles (kilometers) per hour your vehicle is moving.

Odometer

The odometer records the total distance the vehicle has been driven.

Trip Odometer

The trip odometer records the distance of individual trips. Before each trip, set the trip odometer to zero by pushing the reset button.

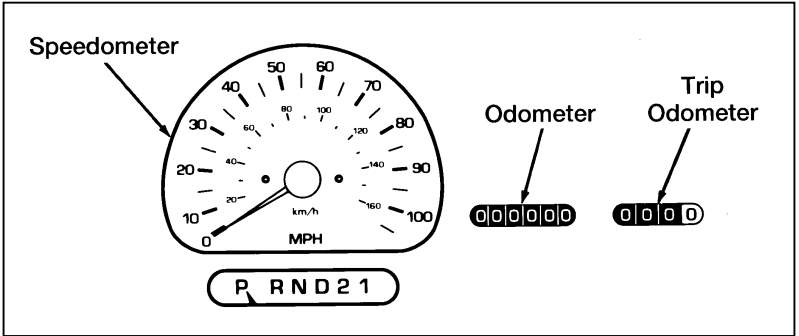

Speedometer, odometer and trip odometer

Tachometer

The tachometer tells you how fast the engine is running by indicating approximate engine revolutions per minute. Driving with the pointer in the red zone may cause engine damage.

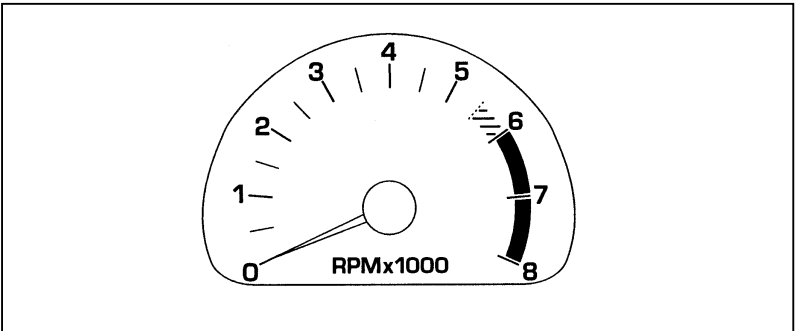

Engine coolant temperature gauge

Warning Lights and Gauges

Electronic Cluster (If equipped)

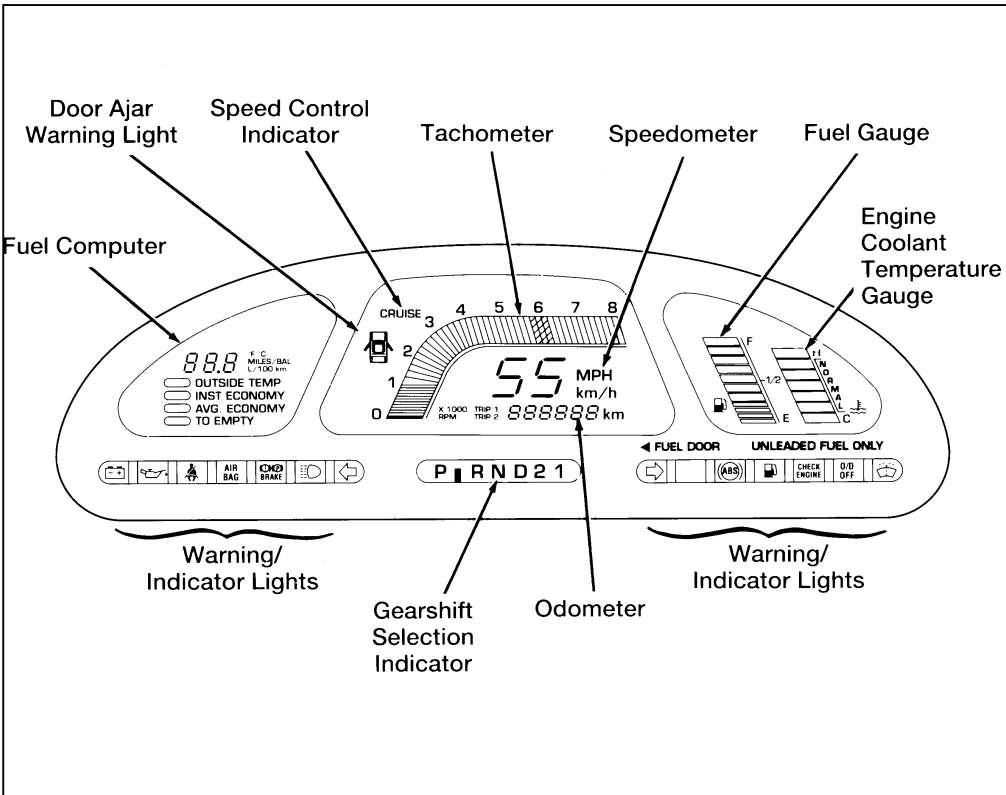

The electronic cluster has all of the same warning lights as the mechanical cluster, however, some of the gauges will be electronic instead of analog. In addition, the electronic cluster has a fuel computer for measuring fuel economy, distance to empty and outside air temperature.

Engine Coolant Temperature Gauge

This gauge shows you the temperature of the engine coolant and is identified by a thermometer symbol. The letter H means that the coolant is hot, C means that it is cold, and NORMAL means that the coolant is within the normal operating range.

The indicator bar on the graph will move into the normal operating range as the engine warms up. When you are in heavy traffic or stop-and-go driving in hot weather, the gauge may read at the very top of the NORMAL range. This is acceptable.

However, if the indicator bar on the graph moves into the H (hot) position, the engine is overheating and may cause engine damage. If this happens, you should stop your vehicle as soon as safely possible. Turn off the engine and let it cool. Check the coolant level to be sure that it is at the proper level. If your vehicle needs more coolant, see *Engine coolant, checking and adding* in the Index and read the section regarding adding coolant.

Warning Lights and Gauges

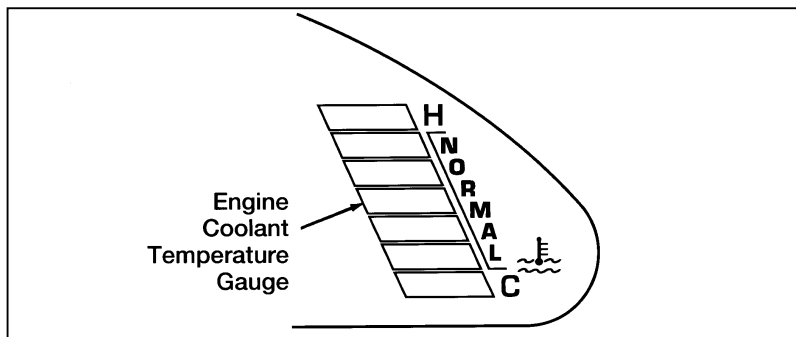

Engine coolant temperature gauge

Fuel Gauge

The fuel gauge displays approximately how much fuel you have in the fuel tank. The number of bars illuminated in the display indicates how much fuel is left. An accurate reading may be obtained when the vehicle is on smooth, level ground.

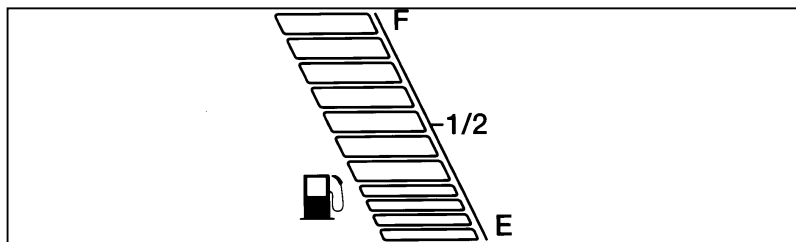

Fuel gauge

Fuel and Distance Computer

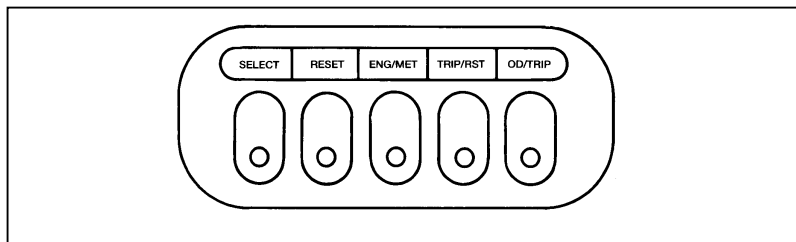

Fuel and distance computer

The fuel and distance computer has five buttons to operate the different functions.

SELECT — The SELECT button lets you choose the functions of the fuel computer. Each time you press the SELECT button, the computer advances to the next choice on the menu. After it reaches the last choice on the menu, it returns to the top of the menu.

RESET — The RESET button is used to reset the Average Economy function. Press the SELECT button until the Average Economy function is displayed. Then press the RESET button.

ENG/MET — The ENG/MET button allows you to change your gauges from English to metric units or from metric to English units. The displays remain in the units you choose until you change them again, even after you turn off the vehicle and start it again.

TRIP/RST — The TRIP/RST button is used to reset the trip odometer mileage. Press the OD/TRIP button until the trip odometer mileage is displayed. Then press the TRIP/RST button.

Warning Lights and Gauges

OD/TRIP — The OD/TRIP button lets you switch the display between the permanent odometer mileage and the trip odometer mileage.

Fuel computer functions

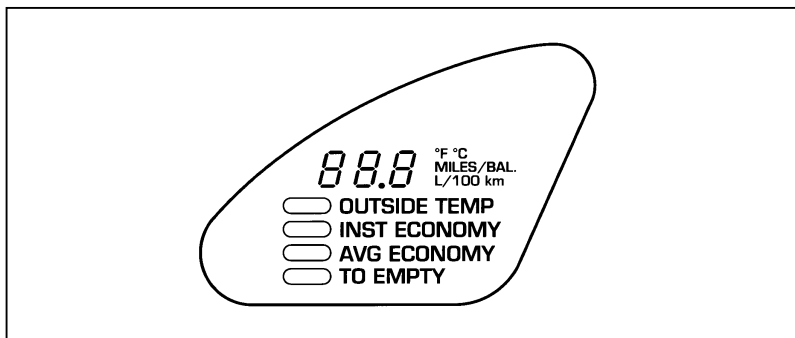

Fuel and distance computer display

OUTSIDE TEMP

This feature lets you display the temperature of the air outside of your vehicle.

The fuel and distance computer is designed to prevent inaccurate temperature display readings. For example, a sudden temperature change (such as driving out of a cool garage on a warm day), may show outside temperature display readings which are lower than expected. The accurate temperature will be displayed after the vehicle has reached the outside temperature and is driven at speeds of 30 mph (48 km/h) or greater.

In the event of a decrease in the outside air temperature, there will be no delay in an accurate temperature display.

INST ECONOMY

Your instantaneous fuel economy is the fuel economy you get at any particular moment. For example, you can see what your fuel economy is in heavy traffic or on the highway.

Factors such as braking, acceleration, and road terrain affect your fuel economy.

To display instantaneous fuel economy, press the SELECT button until the menu displays INST ECONOMY. Your vehicle must be moving for the computer to calculate a fuel economy greater than zero.

AVG ECONOMY

The average fuel economy is an overall average of your fuel economy taken from the last time the reset button was pushed. The computer takes an average of all the types of driving you have done since the RESET button was pressed (highway, city, heavy traffic), and figures out the average fuel economy. You can calculate your average fuel economy as often as you like. For example, you can calculate the average fuel economy for each tank of fuel or for every day.

To display the average fuel economy:

1. Press the SELECT button until the menu displays AVG ECONOMY.
2. You will probably display the average fuel economy for each tank of fuel or for each trip you take. Each time you want to recalculate the average fuel economy, you need to press the RESET button. The average fuel economy must be displayed to reset the fuel computer.

The best time to reset the AVG ECONOMY is when you fill the fuel tank or at the beginning of a trip.

Warning Lights and Gauges

TO EMPTY

The Distance to Empty function tells you approximately how many miles or kilometers you can drive until you run out of fuel.

To see the Distance to Empty, press the SELECT button until the menu displays TO EMPTY. The fuel computer displays approximate distance to empty until you select another function.

To ensure accuracy, turn the ignition to the OFF position when you fill the fuel tank.

Instrument Panel Controls

Instrument Panel

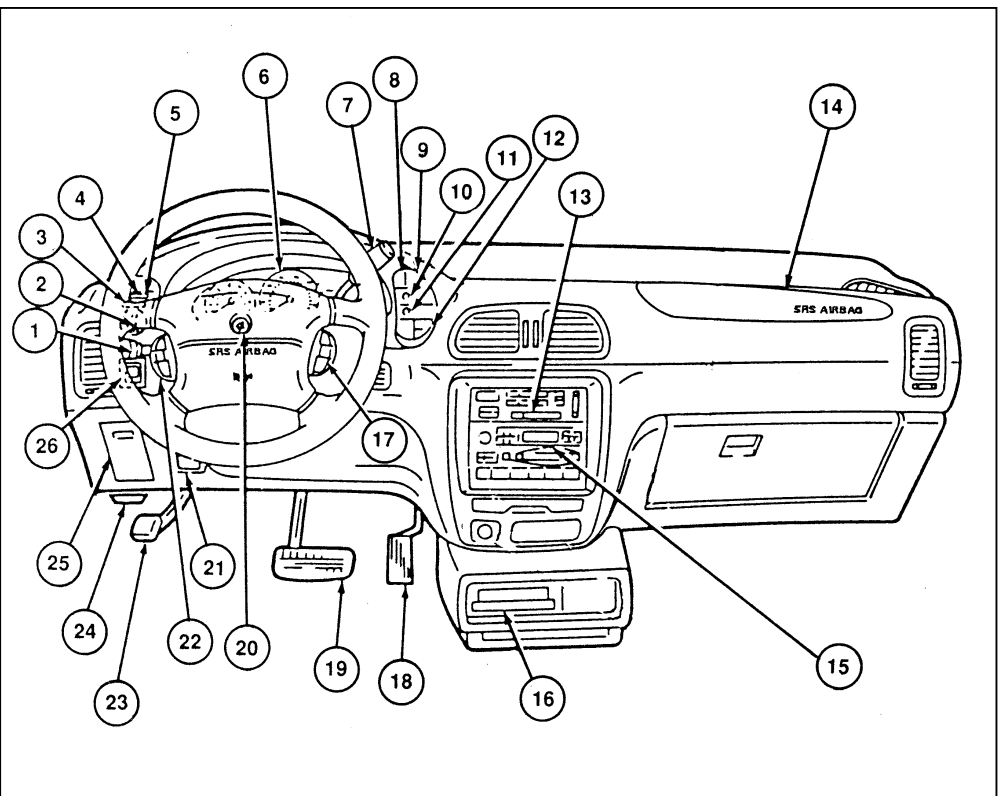

Instrument panel

The instrument panel (dashboard) on your vehicle is divided into several different sections. Illustrations are provided for the major parts of the instrument panel that are explained in this chapter. Some items shown may not be on all vehicles.

1. Turn Signal Lever
2. Headlamp Controls
3. Dim Switch
4. Speed Control Switches*
5. Auto Lamp Control*
6. Instrument Cluster
7. Gearshift Lever (with Overdrive Off Button)
8. Rear Washer Switch
9. Rear Wiper Switch
10. Rear Window Defogger Switch
11. Hazard Flasher Switch
12. Anti-Theft Indicator Light*
13. Climate Controls
14. Passenger-Side Air Bag Location
15. Audio System and Clock
16. CD Changer*
17. Audio Controls
18. Accelerator
19. Brake Pedal
20. Driver-Side Air Bag Location
21. Parking Brake Release
22. Speed Control Buttons*
23. Parking Brake Pedal
24. Hood Release
25. Fuse Panel
26. Power Mirror Controls*

*If equipped

Instrument Panel Controls

The controls for the climate control systems, headlamps, clock, radio, rear window washer and wiper, hazard flasher, power switch, and speed control are all on the instrument panel.

Climate Control Systems

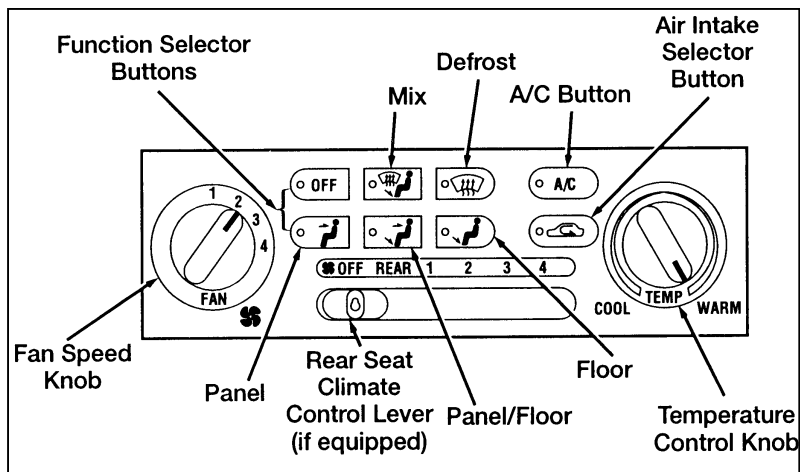

Climate control system panel

Function Selector Buttons

There are six function selector buttons: OFF, Mix, Defrost, Panel, Panel/Floor, and Floor. When you press a function selector button, the indicator light on the button will illuminate. If your vehicle is equipped with a rear passenger compartment climate control system, the instrument panel will also include a rear seat function selector lever.

- The OFF button shuts off the air supply to all outlets and stops all fan operations. Use this setting when driving through an area where outside air is unpleasant or dusty.

⚠ WARNING

Operating with the function selector button in OFF or in the recirculated air mode for extended periods of time in cold weather can result in fog buildup on interior glass surfaces. This fogging can make it difficult to see the road for safe driving. Operating the system with outside air (i.e., with the air intake selector button off) and with one of the five function selector buttons selected (Defrost, Mix, Floor, Panel/Floor, or Panel), will help prevent fogging. Adjust the temperature as necessary for comfort.

- The Mix (🌀) button directs approximately equal amounts of air to the windshield and floor outlets with a small amount to the side windows.
- The Defrost (🌬) button directs air to the windshield with a small amount going to the floor outlets.
- The Panel (📄) button directs air to the instrument panel outlets.
- The Panel/Floor (📄🌬) button directs approximately equal amounts of air to the instrument panel outlets and the floor outlets.
- The Floor (🌬) button directs most of the system's air supply to the floor outlets with a small amount going to the windshield and side window defrosters.

Instrument Panel Controls

Air Outlets

Air intake selector button

The typical air intake selection is outside air. However, for recirculated air, the air intake selector button may be activated. When the air intake selector button is activated (indicator light is on), it prevents the intake of outside air. This is the typical selection when using the air conditioner (if equipped). It recirculates interior air for faster cooling. The recirculated air function also helps to prevent the intake of dusty or unpleasant air.

There are several air outlets on the instrument panel. There are side outlets near the driver's window and passenger's window, two center outlets, floor outlets, and windshield outlets. The direction and amount of air flow from the center and side instrument panel outlets can be adjusted for personal comfort.

NOTE: Selection of the recirculated air mode under cold and humid conditions may result in window fogging due to entrapped humidity within the vehicle. To counteract this circumstance, switch to the Defrost mode and set fan speed to 3 or 4. Adjust air temperature to a "warm" instead of "hot" setting.

Heating Only System (Without air conditioning)

You can heat and ventilate the inside of your vehicle, or defrost the windshield with the function selector buttons, the fan speed knob and the temperature control knob.

An additional push-on/push-off air intake selector button provides for the selection of recirculated inside air (button lighted) or outside air (button not lighted).

Turning on the heat

Heat will be available when the engine has been running for a sufficient time as indicated by the engine coolant temperature gauge.

To heat the inside of your vehicle:

1. Press the function selector button for Floor.

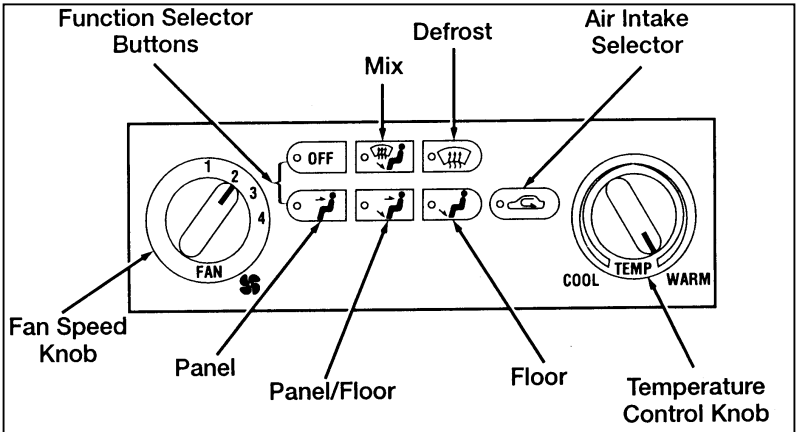

Heating only climate control system panel

2. Turn the temperature control knob toward the WARM (red) area.
3. Turn the fan speed knob to the speed of your choice. When your vehicle warms up, you may want to set the fan speed knob to a lower speed, or adjust the temperature control knob to a lower setting to maintain a comfortable temperature.

Instrument Panel Controls

To defrost the windshield and side windows:

- Press the Defrost button, turn the temperature control knob to the WARM (red) area and turn the fan speed knob to the position of your choice. The recirculated air feature will be automatically turned off in this setting (outside air will be provided).
- To reduce window fogging under extreme conditions, select defrost and high fan speed while reducing temperature to a “warm” instead of “hot” setting. Slightly opening the rear quarter windows may also help dry the interior window surfaces.

To heat and defrost at the same time:

- Press the Mix function selector button, turn the temperature control knob and the fan speed knob to provide the temperature and fan speed you prefer. The recirculated air feature will be automatically turned off in this setting (outside air will be provided).

Controlling the Temperature in Your Vehicle

- To ventilate your vehicle with outside air, make sure that the air intake selector button is set for outside air. Open the instrument panel registers enough to provide the amount of air desired for your comfort.
- To vary the temperature inside your vehicle, move the temperature control knob toward WARM (red) for warmer temperatures and toward COOL (blue) for cooler temperatures. The temperature control knob setting determines the temperature of the air being discharged from the system in all operating modes (heating or A/C).
- Do not place objects under the front seats unless your vehicle is equipped with an underseat storage compartment. Improperly stored objects will interfere with the flow of air to the back seats.

-
- Remove any snow, ice, or leaves from the area below the windshield on the outside of your vehicle. They could block the air intake.

Heating and Air Conditioning System (If equipped)

Turning on the heat

You can heat the inside of your vehicle and defrost the windshield using the function selector buttons located in the control assembly in the instrument panel.

The six function selector buttons are: OFF, Mix (🌀), Defrost (🌀) Panel (🌀), Panel/Floor (🌀), and Floor (🌀). If your vehicle is equipped with a rear seat climate control system, the instrument panel will also include a rear seat climate control lever. To turn on the rear passenger compartment control system, select REAR, 1, 2, 3, or 4. With the lever set to REAR, rear seat passengers will have control of rear fan speed on the rear seat climate control panel. Positions 1, 2, 3, or 4 will control rear fan speed from the front control panel. The temperature of the air from the rear system is controlled by the rear passenger compartment climate control system.

Instrument Panel Controls

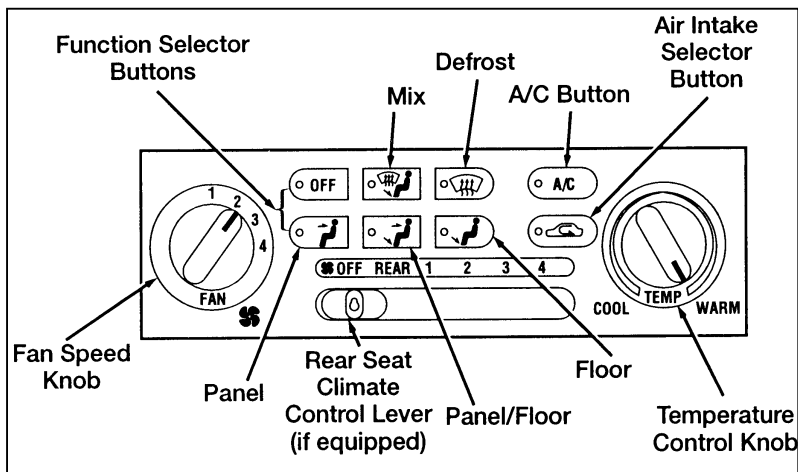

Heating and air conditioning climate control system panel

The standard heating system and the heating portion of the heating and air conditioning system are essentially identical. There is one exception, however; the air conditioning compressor may automatically engage when the Defrost position is selected to aid in defogging and defrosting the inside glass. When Defrost is selected, the A/C compressor will automatically operate when the outside temperature is above approximately 40°F (4°C), whether or not the A/C button is illuminated. Manual selection and illumination of the A/C button in defrost mode does not override the automatic compressor operation discussed above. Refer to the heating system operating instructions covered previously for a more detailed explanation of heating system operation.

Turning on the air conditioner

To cool your vehicle quickly in warm weather:

1. Press one of the function selector buttons (typically Panel, but Panel/Floor, Floor or Mix can be selected).

-
2. Turn the temperature control knob to COOL.
 3. Press the A/C button. The indicator light on the A/C button will illuminate.
 4. The air intake selector button may be in the outside air mode or the recirculated air mode. The recirculated air mode is recommended for best A/C performance when the vehicle interior is very warm. As interior air comfort is reached, you may decide to switch to the outside air mode.
 5. Turn the fan speed knob to the position of your choice.
 6. If your vehicle is equipped with the rear passenger compartment air conditioning unit, it will be on when the front A/C is on and the rear climate control lever is set to REAR, 1, 2, 3, or 4. Refer to the previous section for an explanation of the heating system.
 7. Adjust your instrument panel registers.
 8. If the inside of your vehicle is very warm, you may want to drive for a few minutes with the windows down and the air conditioner on. This forces most of the hot, stale air out of the vehicle and allows the air conditioner to cool down the interior more quickly.

The air conditioner may be used to cool the outside air being drawn into your vehicle, but using recirculated air is more economical and cools your vehicle more quickly.

NOTE: The A/C button independently toggles the A/C system's compressor signal and indicator light ON and OFF in the Panel, Panel/Floor, Floor, Defrost and Mix functions. The A/C button will not operate or light when the system is set in the OFF position. The A/C button will operate in defrost but will not override previously discussed automatic operation.

Instrument Panel Controls

Cooling your vehicle with outside air

Cooling your vehicle with air conditioned outside air is quieter but less economical than using recirculated air. It also has less cooling capacity.

To cool your vehicle using outside air:

1. Turn the air intake selector button off (the outside air position). The air conditioning unit directs outside air through the instrument panel registers.
2. Press one of the function selector buttons.
3. Press the A/C button. The indicator light on the A/C button will illuminate.
4. Turn the temperature control knob to COOL.
5. Turn the fan speed knob to the position of your choice.
6. Make sure the registers in the instrument panel are open.

During periods of high humidity, vapor may be emitted from the air outlets when using the A/C with outside air. Correct this by switching to recirculated air with the A/C button.

Ventilating your vehicle with outside air

In mild weather, you can ventilate your vehicle with outside air. If the outside temperature is less than 70°F (21°C), you can add cool air to your vehicle without using air conditioning. You will get better fuel economy this way.

The procedure for ventilating your vehicle with the standard heating system or with the air conditioning system is the same. Refer to the previous section for instructions on how to ventilate with outside air.

Improving fuel economy

Whenever you turn on the air conditioning, your vehicle uses more fuel because the air conditioning compressor is running. To get better fuel economy while cooling your vehicle, do not use the air conditioner on mild days. Instead, set the air intake selector button in the outside air position and turn the temperature control knob to the COOL position.

Operating tips

When stopped in traffic for long periods of time in hot weather, place the automatic transaxle gearshift selector lever in P (Park) or in N (Neutral) to increase the engine idle speed. This aids in engine cooling and air conditioner efficiency. If the engine overheats, choose the outside air position and turn off the A/C to stop the compressor for a short time.

When your vehicle's engine is operated at full throttle, the air conditioner compressor will automatically be turned off to allow maximum engine power. This may occur during passing or when climbing steep grades. The compressor will return to normal operation within a few seconds after full throttle is no longer needed.

NOTE: The compressor will not operate when the outside temperature is less than about 40°F (4°C).

Instrument Panel Controls

Rear Passenger Compartment Climate Control System for Vehicles with Non-Automatic Temperature Control Systems (If equipped)

If your vehicle is equipped with rear passenger compartment climate controls, the rear seat occupants can select their own personal climate comfort level.

The rear seat climate control system is controlled from the main climate control system on the instrument panel. If the main system is off, the rear system will also be off. If the rear passenger compartment climate control lever is set in OFF, the rear climate controls are turned off. If the lever is set in any of the fan speed positions (1-4), air will be discharged from the rear seat vents at the corresponding speed. However, when the lever is set at REAR, rear seat passengers can control their own fan speed.

The rear passenger compartment climate control system has a fan speed knob which controls the speed at which air is discharged from the vents. The vent selection switch determines whether the air is discharged from the upper vents or the lower (floor) vents. The temperature control knob controls the air temperature.

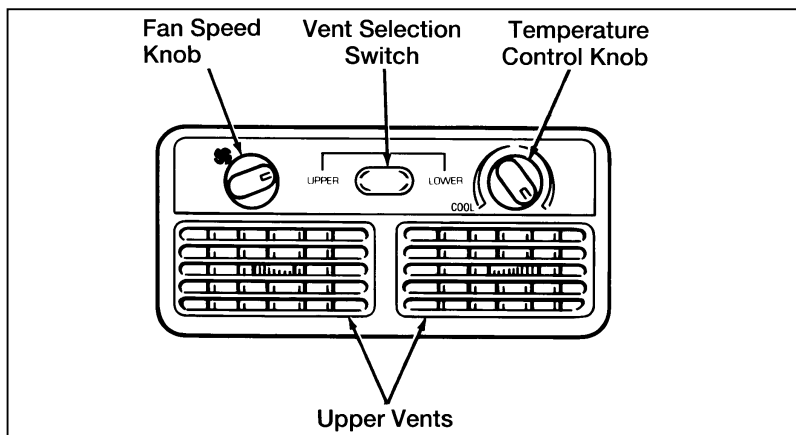

Rear seat climate control system panel





NOTE: For maximum heating and cooling for front seat passengers, set the rear fan switch to the OFF position.

Instrument Panel Controls

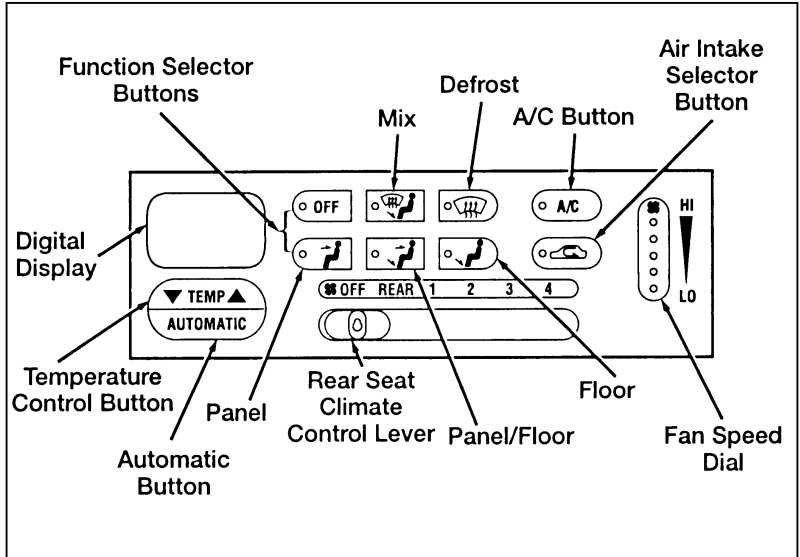
Automatic Temperature Control System

The control for your Automatic Temperature Control (ATC) is located at the center of the instrument panel above the radio. The ATC operates only when the ignition key is turned to the ON position and the vehicle is running.



To turn the ATC on, push the **AUTOMATIC** button or any of the five airflow function selector buttons: , , , , or .

To turn the ATC off, press the **OFF** button.

To change the temperature in the display window, select any temperature between 65°F (18°C) and 85°F (29°C) using the **▼ TEMP ▲** button.

The ATC maintains the temperature you select and automatically controls the airflow for your comfort. It also allows you to override the automatic operation of airflow and fan speed with manual function selector buttons and the fan speed dial.

When you select the AUTOMATIC button, the system determines airflow location and fan speed automatically. It also automatically determines whether you will be receiving fresh outside airflow, recirculated interior airflow, or a combination of both. You can manually override the airflow source (outside or recirculated air) and airflow location by selecting one of the function selector buttons. You can also manually override the fan speed by rotating the fan speed dial.

Whether you operate in the AUTOMATIC mode or manually override the AUTOMATIC mode settings, the ATC will continue to maintain the air temperature you have selected. However, if you choose to manually override the airflow location by selecting one of the function selector buttons, you will also need to select the A/C button if you desire cool air-conditioned air. (Your ATC automatically operates the air conditioning [if required] when you are in the AUTOMATIC mode without illuminating the A/C button, but the system requires you to manually select the A/C button if you desire A/C operation when you manually override airflow location.)

If you want continuous maximum cooling, push the ▼ side of the TEMP button until 60°F (16°C) shows in the display window. The ATC will cool at its maximum level and disregard the 60°F (16°C) setting until a warmer temperature is selected. If you want continuous maximum heating, push the ▲ side of the TEMP button until 90°F (32°C) shows in the display window. The ATC will provide maximum heat regardless of the 90°F (32°C) setting until a cooler temperature is selected.

Instrument Panel Controls

The display window and the function selector buttons indicate how the system is operating. The display window shows the selected temperature and displays AUTO if you are operating in the AUTOMATIC mode. If you override the automatic mode by selecting any of the function selector buttons, AUTO no longer appears in the display window and the appropriate function selector button(s) illuminate. The display window also indicates manual (thumbwheel) control of the fan speed when a  is shown.

Automatic Operation

Push the AUTOMATIC button and select the desired temperature. The selected temperature and AUTO appear in the display window. The ATC heats or cools to achieve the set temperature. It is important to note that if the ATC engages your vehicle's air-conditioning, it will do so automatically without illuminating the A/C button.

When in AUTOMATIC and weather conditions require heat, air is sent to the floor. However, a feature is included in the ATC to prevent blowing cold air to the floor if the engine coolant is not warm enough to provide heating. Within three or four minutes (of determining the engine coolant is not warm enough) the fan speed gradually increases and airflow changes to the floor.

If specific conditions exist (such as window fogging) the five override buttons allow specific airflow selection. The thumbwheel allows you to adjust the fan speed to suit your needs.

Temperature Selection

The ▼ TEMP ▲ button on the left side of the control panel is for temperature selection. The ▼ side lowers the set temperature, and the ▲ side raises the set temperature. Press and hold either side of the button to rapidly change the temperature setting in one degree increments to either 65°F (18°C) or 85°F (29°C). Then, the set temperature jumps 5°F and stops at either 60°F (16°C), which is maximum cooling, or 90°F (32°C), which is maximum heating.

Changing the Display Mode (English/Metric)

To switch between the English and Metric display mode, press the DEFROST and A/C buttons simultaneously while rotating the fan speed dial upward until it stops moving. After one second, the display will begin to toggle between English and Metric.

Fan Speed and Thumbwheel

The ATC automatically adjusts the fan speed to the existing conditions. To control the fan speed yourself, use the thumbwheel located at the extreme right side of the ATC control panel. Using the thumbwheel cancels the automatic fan speed control, and causes a  to appear in the display window. Rotate the thumbwheel up for HI speeds and down for LO speeds.

To return to auto fan control, press the AUTOMATIC button.

Airflow Function Selector Buttons

Your ATC has five buttons which allow you to make special selections for airflow. The buttons are grouped in the middle of the ATC panel and allow you to determine airflow location. Pressing any of the function selector buttons illuminates the button pushed and directs airflow to the appropriate location. The temperature of the airflow will still be automatically controlled. Return to fully automatic operation by pushing the AUTOMATIC button.

Instrument Panel Controls



Push this button for airflow to the floor and windshield at the same time. The  indicator light illuminates, and the display window shows the set temperature. However, the air is not cooled regardless of the temperature setting unless the A/C button is pushed.



Press this button to obtain maximum airflow to the windshield. Adjust the temperature setting as required for defrosting. The  indicator light illuminates and the display window shows the set temperature. When the outside temperature is about 50°F (10°C) the air conditioning functions in order to dehumidify the air to prevent window fogging.



Push this button to select airflow through the instrument panel registers. The  indicator light illuminates and the display window shows the set temperature. The ATC heats the air if the selected temperature is warmer than the outside air coming into the vehicle. However, the air is not cooled regardless of the temperature setting unless the A/C button is pushed.



Push this button for air from the floor and instrument panel registers at the same time. The  indicator light illuminates and the display window shows the set temperature. The ATC heats the air if the selected temperature is warmer than the outside air coming into the vehicle. However, the air is not cooled regardless of the temperature setting unless the A/C button is pushed.



Push this button to direct airflow to the floor. The  indicator light illuminates and the display window shows the set temperature. The ATC heats the air if the selected temperature is warmer than the outside air coming into the vehicle. However, the air is not cooled regardless of the temperature setting unless the A/C button is pushed.

Air Conditioning and Air Recirculation

Activate the air conditioning in any of the function selector override modes by pressing the A/C button. The A/C indicator light on the button illuminates to verify activation, and cooled air flows from the vents. Fan speed continues to be controlled by the ATC unless the fan speed thumbwheel is used to override the ATC.

Press the  button to choose air recirculation. In this mode the ATC system recirculates the air inside the vehicle rather than drawing air from outside. Use this mode together with the air conditioning to rapidly cool the inside of the vehicle or to dehumidify the air inside the vehicle.

Rear Passenger Compartment Climate Control System with Front Passenger ATC

If your vehicle is equipped with ATC, the rear passenger compartment will also have climate controls so that rear seat occupants can select their own personal climate comfort level.

The rear seat climate control system is controlled from the main ATC system on the instrument panel. If the front ATC system is off, the rear system will also be off. Also, if the rear seat climate control lever is set in OFF, the rear climate controls are turned off.

Instrument Panel Controls

If the rear seat climate control lever is set in any of the fan speed positions (1-4), air will be discharged from the rear seat vents at the corresponding speed. Rear seat passengers can choose airflow to be distributed out of the upper or lower vents by using the vent selection switch on the rear climate control panel. The air temperature from the rear climate control system will be automatically controlled by the front ATC system. Rear seat passengers cannot control fan speed or air temperature by using the temperature control knobs on the rear climate control panel.

If the rear seat climate control lever is set in the REAR position, the front ATC system will not control the rear climate control system. Rear seat passengers can control fan speed, upper or lower air distribution, and temperature control from the rear system by using the rear climate controls.

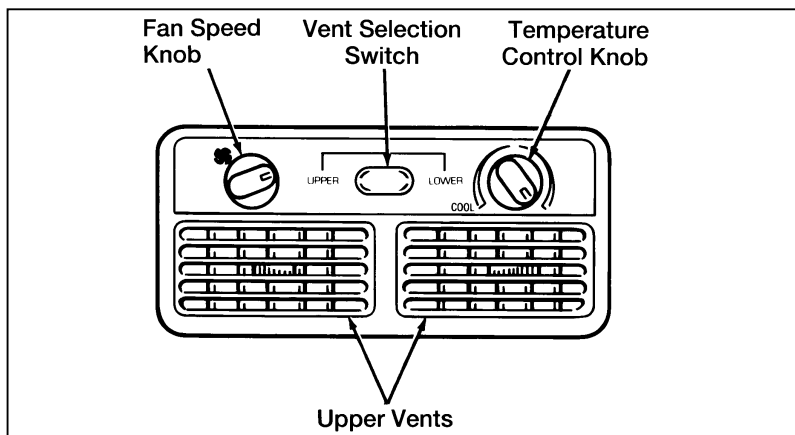

Rear seat climate control system panel

Liftgate Window Features

Rear Window Defogger (If equipped)

The defogger for the rear liftgate window clears frost, fog, or thin ice from both the inside and outside of the rear window. The defogger operates with the ignition in the ON position.

If your vehicle is equipped with heated exterior mirrors, they activate when the rear window defogger is switched on.

The control switch is located on the instrument panel to the right of the steering column.

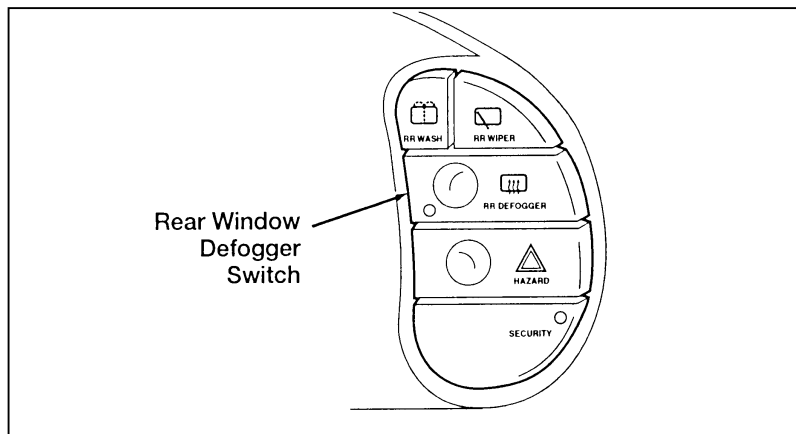

Rear window defogger switch location

Clear away any snow that is on the rear window and outside rearview mirrors before using the defroster. With the engine running, push the defroster button.

After approximately 10 minutes, the defroster will turn off. If the window or mirrors are still not clear, turn the defroster on again.

Instrument Panel Controls

The defroster will turn off when the ignition key is turned to the OFF or START position.

Never use sharp instruments or abrasive window cleaners to clean the inside of your rear window. If you do, you may damage the wires that are bonded to the inside of the rear window, and cause damage to the rear window defogger.

Rear Wiper and Washer

The controls for the rear wiper and washer can also be found on the instrument panel to the right of the instrument cluster. The rear wiper and washer controls operate with the ignition in the ACC and ON positions.

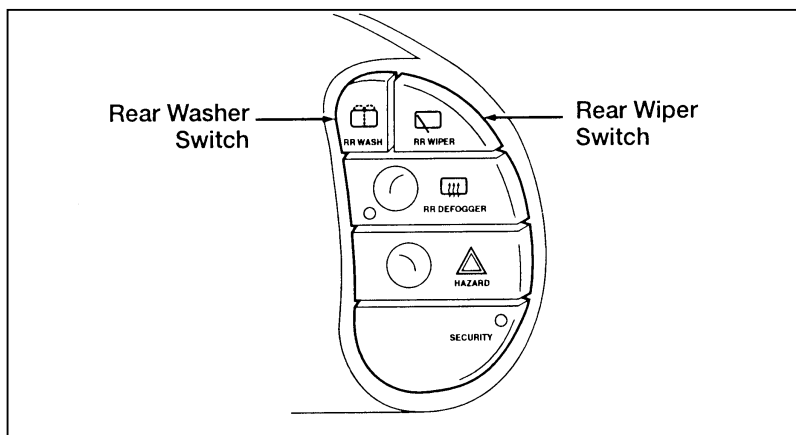

Rear wiper and washer switch locations

To turn on the rear wiper, press the RR WIPER switch. The wiper will operate until it is turned off. The wiper will complete one cycle every 10 to 15 seconds. To turn off the rear wiper, press the RR WIPER switch a second time.

To activate the rear washer, press the RR WASH switch. For a constant spray, hold the switch for a few seconds. For less washer fluid, press the switch once and release it. When you activate the washer, the wiper will cycle twice and then stop.

Do not activate the washer for longer than fifteen seconds continuously. This could damage the washer pump system.

Hazard Flasher Switch

The hazard flasher is used to alert other drivers to hazardous situations.

The hazard flasher switch operates the same lamps as the turn signal lever. When the hazard flasher is activated, all of these lamps will flash on and off. The turn signal indicators cannot be used when the hazard lamps are flashing. Operation of the hazard flashers does not affect operation of the brakelamps.

The flashers work even with the key out of the ignition. The flashers will work for up to two hours when the battery is fully charged and in good condition. They will not drain the battery excessively. If the flashers run for longer than two hours or if your battery is not fully charged, your battery may be drained to the point where the vehicle will not start.

The hazard flasher switch is located on the instrument panel to the right of the instrument cluster.

To use the hazard flasher:

1. Push the HAZARD switch; you will see the turn signal arrows flash.
2. To stop the hazard flashers, push the HAZARD switch again.

Instrument Panel Controls

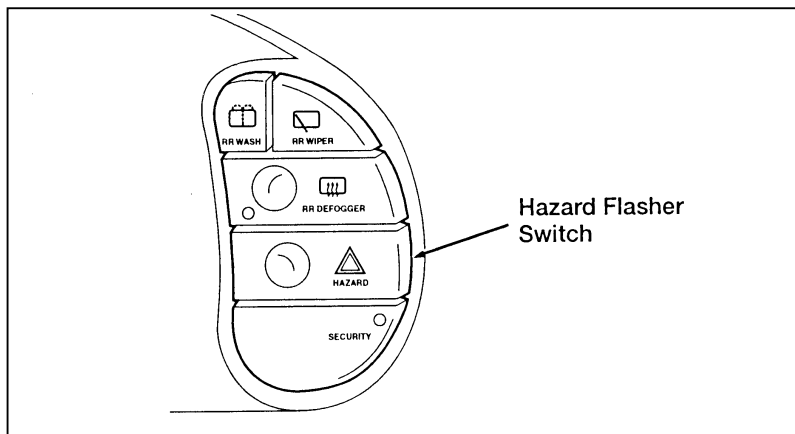

Hazard flasher switch location

Interior and Exterior Lights

To turn on the headlamps, parking lamps, marker lamps, tail lamps and instrument panel lights, use the headlamp control knob, to the left of the instrument cluster.

1. Turn the headlamp knob to the first position to turn on the parking lamps, tail lamps, license plate lamps, marker lamps and instrument panel lights.
2. Turn the headlamp knob to the second position to turn on the headlamps in addition to the parking lamps, tail lamps, license plate lamps, marker lamps and instrument panel lights.

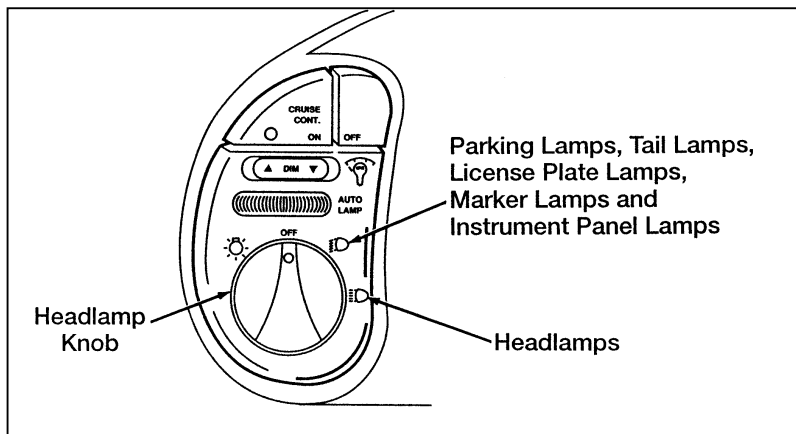

The headlamp control knob

A chime will sound if any of the exterior lamps are on when the driver's door is opened.

Cleaning the Exterior Lamps

Do not use dry paper towel, chemical solvents or abrasive cleaners to clean the lamps, as these may cause scratches or crack the lamps.

Daytime Running Light (DRL) System (Canadian vehicles only)

The Daytime Running Light (DRL) system turns the high beam headlamps on, with a reduced light output, when:

- the vehicle is "running"
- the vehicle has a fully released parking brake
- the headlamp system is in the OFF position

NOTE: You may notice that the lights flicker when the engine is turned on or off. This is a normal condition.

Instrument Panel Controls

WARNING

The Daytime Running Light (DRL) system will not illuminate the tail lamps and parking lamps. Turn on your headlamps at dusk. Failure to do so may result in a collision.

Lighting Up the Instrument Panel

The instrument panel lights can be turned on by turning the headlamp control knob to either the first or second position. You can brighten or dim the instrument panel lights with the DIM switch. The DIM switch is located near the headlamp controls.

Pushing and holding the right side of the switch will continue to brighten the lights until the maximum brightness is reached. Release the switch to maintain the desired brightness. The DIM feature works similarly to dim the instrument panel lights when the left side of the switch is pushed.

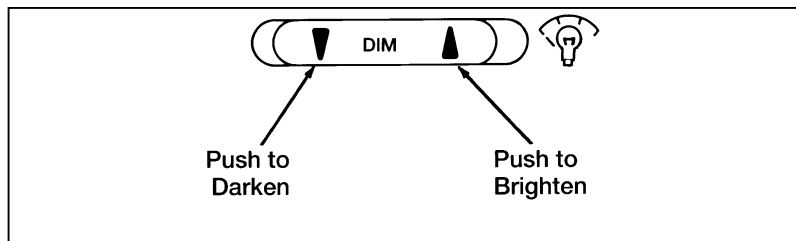

The instrument panel brightness control

Autolamp On/Off Delay System (If equipped)

The autolamp sets the headlamps to turn on and off automatically. You can use the autolamp to:

- turn on the headlamps automatically at night
- turn off the headlamps automatically during daylight
- keep the headlamps on for approximately three minutes after you turn the key to OFF.

To set the autolamp:

1. Make sure the headlamp control knob is in the OFF position. If the knob for the headlamps is on, the autolamp system is canceled.
2. Turn the ignition key to ON to start your vehicle.
3. Use the autolamp thumbwheel to activate the autolamp feature. It is located to the left of the instrument cluster. The white mark indicates the approximate center of the thumbwheel.

Instrument Panel Controls

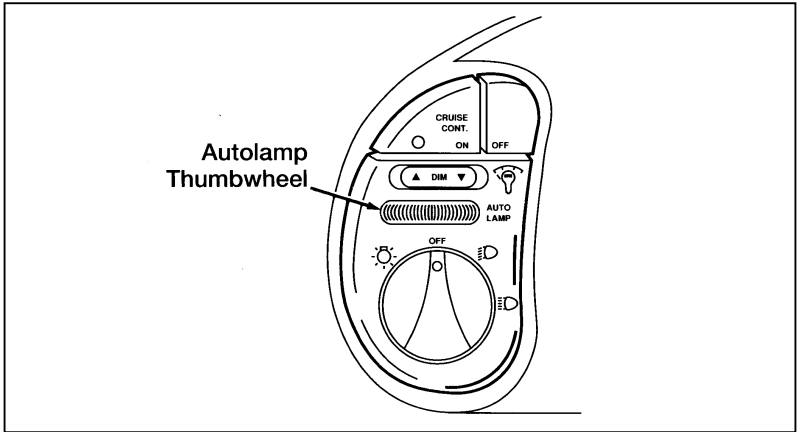

Autolamp thumbwheel location

4. Move the thumbwheel all the way to the right. The autolamp will automatically turn the lamps on and off.

NOTE: Be sure that you do not put anything on top of the photodiode located in the top right side of the instrument panel speaker grille. The photodiode controls the autolamp; if it is covered, the photodiode reacts as if it is nighttime, and the headlamps will be illuminated.

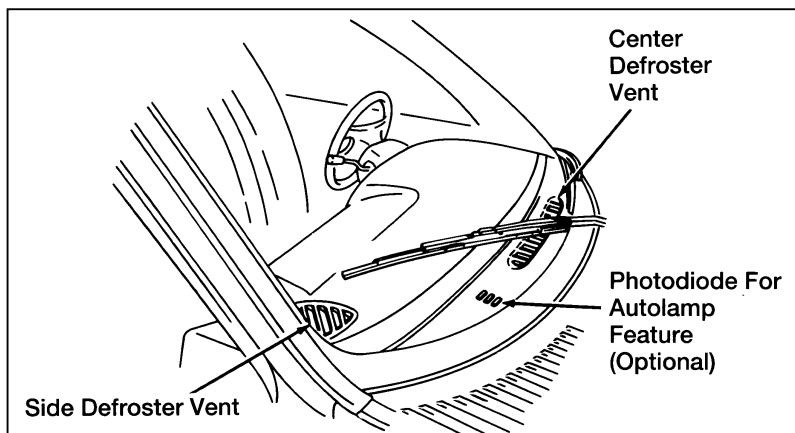

Autolamp photodiode location

To turn the autolamp off, move the thumbwheel all the way to the left.

You can set the autolamp so the headlamps stay on for approximately three minutes after you turn off your ignition. The farther the thumbwheel is moved to the right, the longer the headlamps stay on.

The chime will sound when the autolamp system turns the headlamps on and the driver's door is open.

Interior Lamps

The front dome lamp is located overhead between the driver and front passenger seats. However, if your vehicle is equipped with a power sun roof, the dome lamp is located behind the driver's seat.

The rear dome lamp is located overhead near the rear seating positions.

Instrument Panel Controls

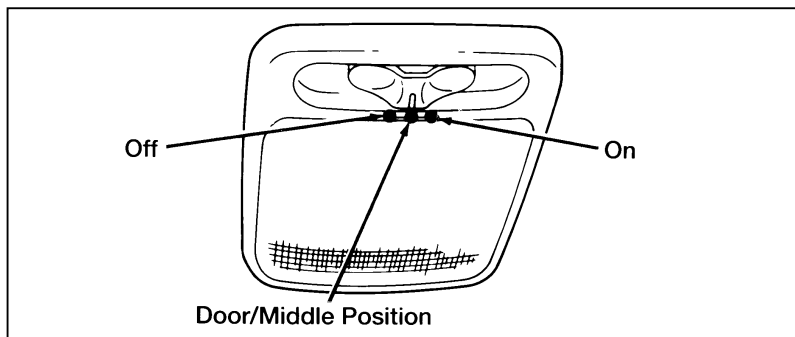

The dome lamp switch positions

Either dome lamp will stay illuminated if the switch is pushed to the ON position. The dome lamps will stay off if the switch is pushed to the OFF position. When the switch is positioned to the door/middle position, the dome lamps will come on when either of the front doors or the sliding door is opened. The front dome lamp, footwell lamps, and the sliding door step lamp have a time delay feature and will gradually dim within about 15 seconds.

The rear dome lamp also illuminates when the liftgate is opened and goes off when it is closed. However, the rear dome lamp will not remain lit in the ON position unless the ignition switch is in the ON position. This feature is intended to help avoid a run-down battery which can occur when a light is left on unintentionally.

If the vehicle doors are not fully closed and the interior lamps remain illuminated, they will eventually turn off automatically to prevent the battery from becoming discharged. Lamps that illuminate when the front doors and the sliding door are open will turn off after approximately 30 minutes. Lamps that are illuminated when the liftgate is open will turn off after approximately 60 minutes.

Illuminated Entry System (If equipped)

If your vehicle is equipped with this option, the interior courtesy lamps (footwell, stepwell, and dome lamps) will light when either of the front doors or the sliding door is opened. If you have the optional Keyless Entry System the lamps will also light whenever any keypad or remote keyless entry transmitter button is pressed. One of the stepwell lamps is located near the sliding door entrance and there is one on each front door. The footwell lamps are located below the instrument panel near the driver's and front passenger's feet. When the liftgate is opened, the optional liftgate lamp, rear dome lamp and sliding door stepwell lamp are illuminated.

The lamps that have the time delay feature will automatically dim until they turn completely off approximately 15 seconds after the doors are closed. When the key is placed in the ignition and turned to the ON position, the lamps will turn off.

Overhead Map Lamps (If equipped)

The power sunroof overhead console also contains the overhead map lamps.

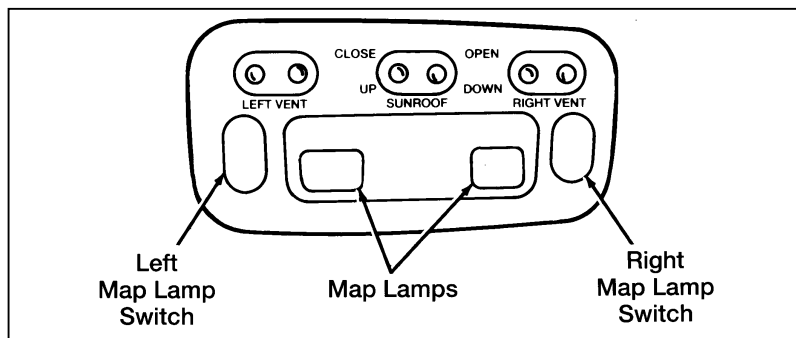

The overhead map lamps

Instrument Panel Controls

You can turn the map lamps on and off by pressing the switches next to the lamps.

Radio

For information about the radio in your vehicle, refer to the *Electronic Sound Systems* chapter in this owner guide.

Clock Controls on Electronic Radios

The electronic radios have a built-in clock. For complete operating instructions, refer to the *Electronic Sound Systems* chapter in this owner guide.

Radio Antenna

The fixed radio antenna is mounted on the front fender on the passenger's side of the vehicle.

Power Antenna (If equipped)

The power antenna is located on the front fender on the passenger's side of the vehicle. It will automatically raise when the radio is turned on and lower when the radio is turned off.

NOTE: The radio must be turned off so that the antenna will retract prior to entering a car wash. Failure to retract the antenna could result in damage to the antenna, antenna base, or vehicle.

Cleaning the Instrument Panel Lens

Clean the instrument panel lens with a soft cloth and a glass cleaner, such as Ford Ultra-Clear Spray Glass Cleaner, or equivalent. Do not use paper towel or any abrasive cleaner to clean the lens as these may cause scratches.

Steering Column Controls

The controls on the steering column and wheel are designed to give you easy access to the controls while you are driving.

Turn Signal Lever

You can use the turn signal lever on the left side of the steering column to:

- operate the turn signals.
- turn the headlamps to high beam.
- flash the headlamps.
- turn the windshield wipers and washer on/off.

Turn Signals

Move the lever up to signal a right turn. Move it down to signal a left turn. The corresponding indicator light in the instrument cluster will flash.

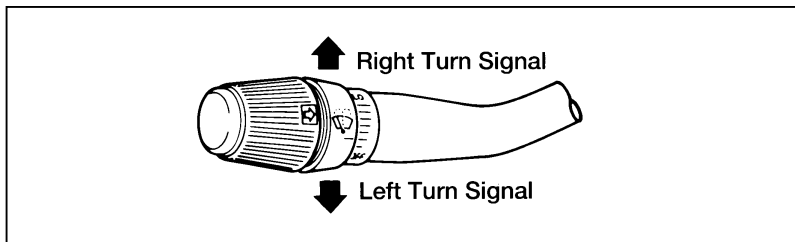

The turn signal lever

If the turn signal stays on after you turn, move the lever back to the center (off) position.

For lane changes, move the lever far enough to signal but not to latch. The lever will return to the off position when you release it.

If the turn indicator light in the instrument panel does not illuminate or remains on (does not flash) when you signal a turn, the turn signaling system is malfunctioning. Have this condition corrected as soon as possible, and use the accepted hand signals until the turn signal system is repaired.

Cornering Lights

Your vehicle is equipped with special cornering lights designed to provide additional illumination toward the direction you are turning. The corresponding light comes on when a turn is signaled.

High Beams and Flashing the Lamps

To turn on the high beams, turn the headlamps on and push the turn signal lever away from you until it latches. When the high beams are on, the high beam indicator light on the instrument panel is illuminated.

To return to the low beam setting, pull the turn signal lever toward you until it latches back into the neutral position. The high beam indicator light turns off.

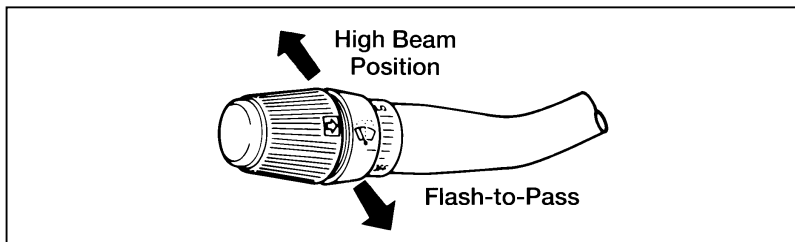

High beam and flash-to-pass operation

To flash the headlamps, pull the turn signal lever toward you for a moment and then release it. The high beam headlamps will flash whether the headlamps are on or off.

Steering Column Controls

Windshield Wipers and Washer

Variable Interval Wipers

Your vehicle has wipers that you can set to operate at varying intervals. For example, you can set the interval so they wipe less often in light rain or more often in heavier rain.

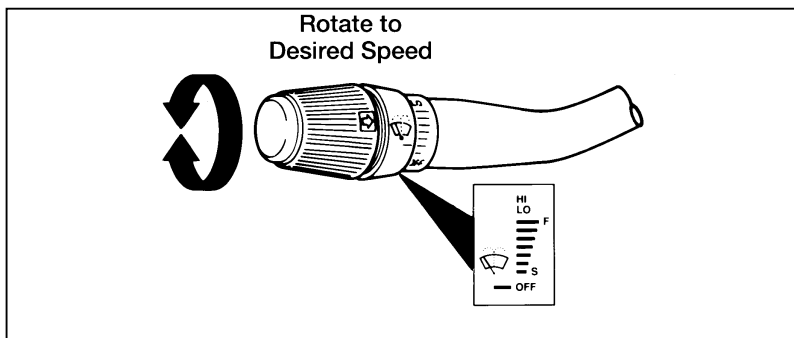

Variable interval wiper control

To set the interval wipers, rotate the knob at the end of the turn signal lever to the most effective interval. The farther the knob is from the OFF position, the faster the wipers move.

To clean the windshield, push in the end of the knob on the turn signal lever. For a constant spray, push and hold the end of the knob. If the windshield wipers are off, they automatically turn on for two wipe cycles after you squirt the washer fluid.

Do not try to clean the windshield when the washer fluid container is empty and never activate the washers for more than fifteen seconds continuously. This could damage the washer pump system.

⚠ WARNING

In freezing weather, the washer solution may freeze on the windshield and obscure your vision. Always warm up the windshield with the defroster before you use the washer fluid. If you cannot see through the windshield clearly, it can increase the risk of being involved in a collision.

For information about refilling the washer fluid or replacing your windshield wiper blades, see *Windshield washer fluid and Wipers* in the Index.

Gearshift Lever

The gearshift lever on your vehicle is mounted on the steering column. On the end of the gearshift lever is the Overdrive On/Off button. To learn about the operation of the gearshift lever and the Overdrive On/Off button, see the *Driving Your Villager* chapter.

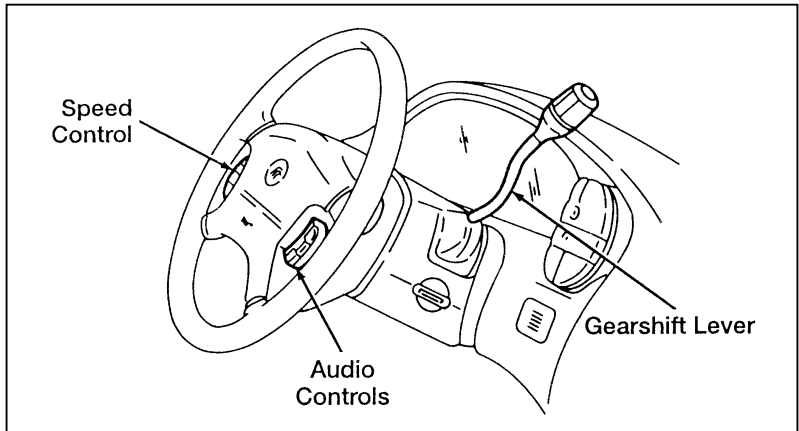

Gearshift lever location

Steering Column Controls

Tilt Steering

⚠ WARNING

Never adjust the steering wheel when the vehicle is moving. You could lose control of the vehicle and injure someone.

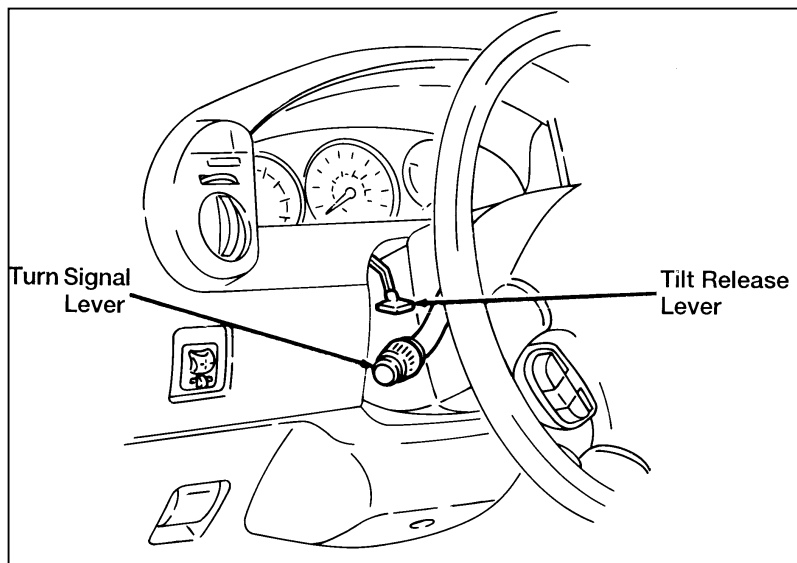

Tilt release lever location

To change the position of the steering column, pull the release lever on the column down. Move the steering wheel to the desired position and raise the lever to lock the steering wheel in place.

Speed Control (If equipped)

The speed control system allows your vehicle to maintain a set speed above 30 mph (48 km/h) without keeping your foot on the accelerator pedal.

Avoid using the speed control when driving under the following conditions:

- when it is not possible to keep the vehicle at a set speed
- in heavy traffic or in traffic that varies in speed
- on winding or hilly roads
- on slippery roads (rain, snow, ice, etc.)
- in very windy areas

To activate the speed control, push the main switch (CRUISE CONT. ON); the switch is located in the group of controls to the left of the steering wheel. The indicator light on the switch will come on.

Steering Column Controls

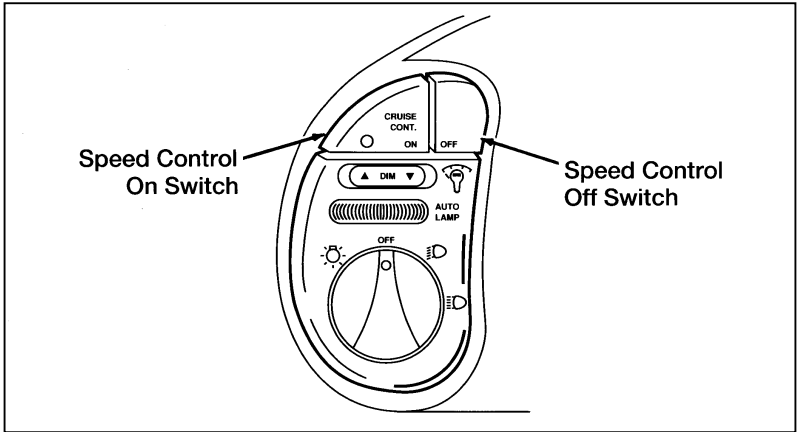

Speed control main switch location

Setting the Speed Control

To set the speed control, accelerate your vehicle to the desired speed (at least 30 mph [48 km/h]), push and release the COAST/SET button on the left side of the steering wheel. The CRUISE light in the instrument cluster will come on. Take your foot off the accelerator pedal. Your vehicle will maintain the set speed.

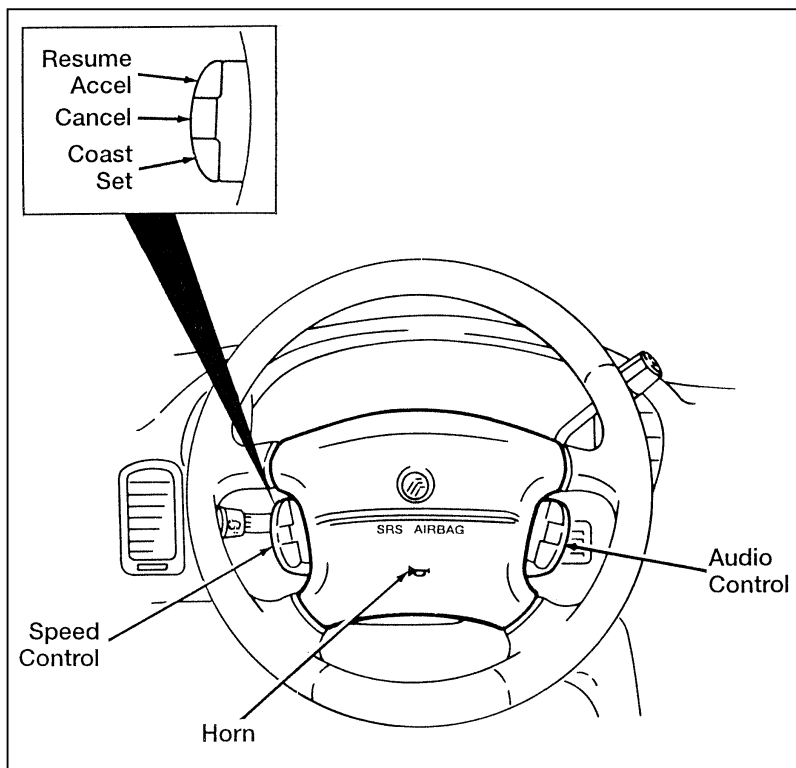

Speed control buttons on the steering wheel

Steering Column Controls

Accelerating With the Speed Control Operating

To pass another vehicle while the speed control is activated, press the accelerator pedal. When you release the pedal, the vehicle will return to the previously set speed.

Driving Uphill or on a Steep Grade

The vehicle may not maintain the set speed when going up or down steep hills. If this happens, drive without the speed control.

When driving uphill, especially with a heavy load, you may notice your speed decreasing, even if you have the speed control set. If the speed drops more than 8 mph (13 km/h), it is normal for the automatic speed control feature to be cancelled. You may need to help your vehicle maintain the selected speed by driving without the speed control when driving up steep grades.

Cancelling the Speed Control

To cancel the preset speed, follow one of these three methods:

- Push the CANCEL button on the left side of the steering wheel; the CRUISE light will go out.
- Tap the brake pedal; the CRUISE light will go out.
- Press the main OFF switch to the left of the steering wheel. Both the CRUISE CONT. ON switch indicator and the CRUISE light in the instrument cluster will go out.

If you unintentionally press the brake pedal while pushing the RESUME/ACCEL button to reset the cruising speed, press the OFF switch once and then reactivate the system by pressing the CRUISE CONT. ON switch.

The speed control will automatically be canceled if the vehicle slows down below approximately 8 mph (13 km/h).

Resetting the Speed Control

To reset at a higher speed, use one of the following methods:

- Press the accelerator pedal. When the speedometer indicates the desired speed, push and release the COAST/SET button.
- Push and hold the RESUME/ACCEL button. When the vehicle attains the speed you desire, release the switch.
- Push, then quickly release the RESUME/ACCEL button. Each time you do this, the set speed will increase by about 1 mph (1.6 km/h).

To reset at a lower speed, use one of the following methods:

- Lightly tap the brake pedal. When the speedometer indicates the desired speed, push the COAST/SET button and release it.
- Push and hold the COAST/SET button. Release the button when the vehicle slows down to the desired speed.
- Push, then quickly release, the COAST/SET button. Each time you do this, the set speed will decrease by about 1 mph (1.6 km/h).

Resuming a Set Speed

To resume the preset speed, push and release the RESUME/ACCEL button. The vehicle will resume the last set speed as long as the vehicle is traveling at a speed over 30 mph (48 km/h).

Steering Column Controls

Information About the Speed Control System

If the speed control system malfunctions, it will cancel automatically. The CRUISE indicator in the instrument cluster will then blink to warn the driver.

When the CRUISE indicator blinks, press the speed control OFF switch and have the system checked by your Ford or Lincoln-Mercury dealer.

The CRUISE indicator light may blink if the CRUISE CONT. ON switch is pressed while pushing the RESUME/ACCEL, COAST/SET, or CANCEL buttons located on the right side of the steering wheel.

Your vehicle has a variety of features designed for your comfort, convenience and safety. Read this chapter to find out about standard and optional features.

Doors

For information on the liftgate refer to the *Liftgate* section later in this chapter.

Exterior Locks

To unlock the door with the key, place the key in the door lock cylinder and turn it toward the rear of the vehicle. To unlock all the doors, turn the key toward the rear of the vehicle a second time within 2-3 seconds (if equipped). To lock the door with the key, turn it toward the front of the vehicle. Return the key to the neutral position (straight up in the lock cylinder) to remove it.

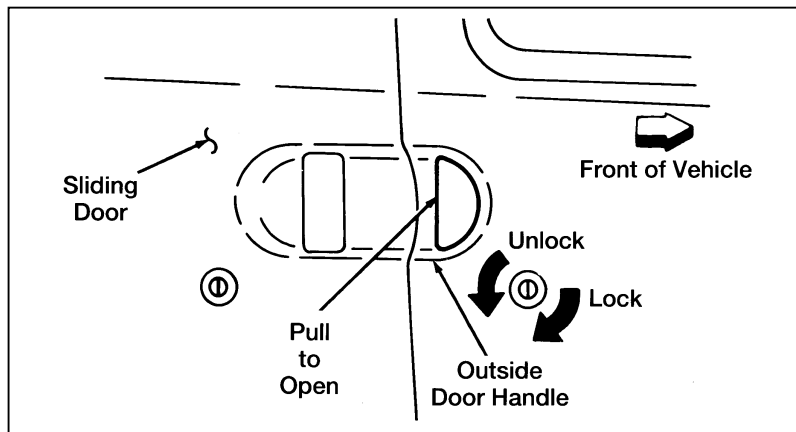

The exterior door lock — passenger side doors shown

Automatic Door Lock

If your vehicle is equipped with the optional power door locks, locking the driver's door with the key or with the manual rocker switch will also lock all other doors. However, when the driver's door is unlocked, with the key or with the manual rocker switch, other doors remain locked.

Anti-Lockout

Your vehicle is equipped with an anti-lockout feature which prevents the driver's side door from being locked while the key is in the ignition. To lock the driver's side door, remove the key from the ignition and then use either the manual rocker switch or the door lock cylinder.

Accessory Delay (If equipped)

Accessory Delay is a feature that allows vehicles equipped with power windows and the power sunroof to operate all power windows and the power sunroof for 15 minutes after the ignition is turned to OFF or until the driver's door is opened (after ignition is turned to OFF).

Sliding Door

The sliding door allows rear seat passengers to enter and exit easily.

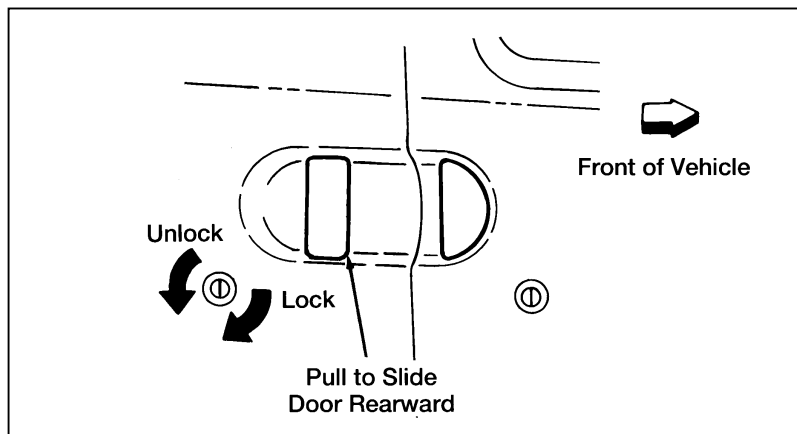

The sliding door exterior lock

To lock the sliding door, push the right side of the rocker switch. To unlock the sliding door, push the left side of the rocker switch.

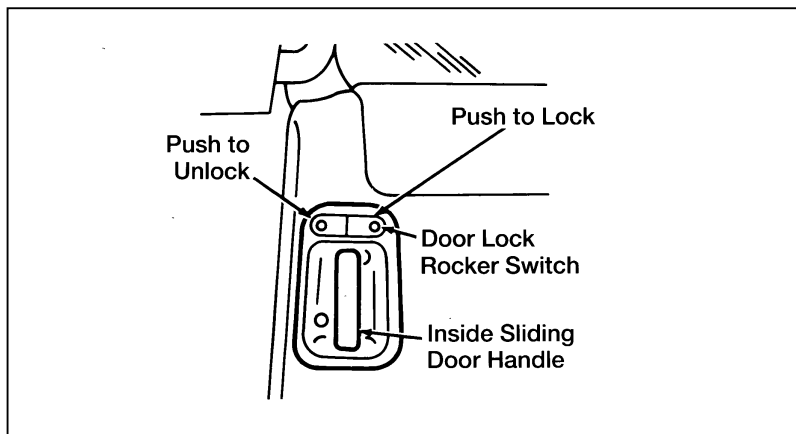

The sliding door interior lock

To open the sliding door from inside or outside of the vehicle, pull the handle toward the rear of the vehicle. The door will stay open if you slide it all the way back until the catch at the bottom of the door engages.

To release the catch and close the door, pull the handle toward the front of the vehicle. Be sure it is fully closed.

Childproof Lock for the Sliding Door

Your vehicle has a childproof lock for the sliding door. If you set the childproof lock, the sliding door cannot be opened from inside the vehicle.

This lock will keep children from opening the door from the inside; the door can still be opened from the outside if the door is unlocked.

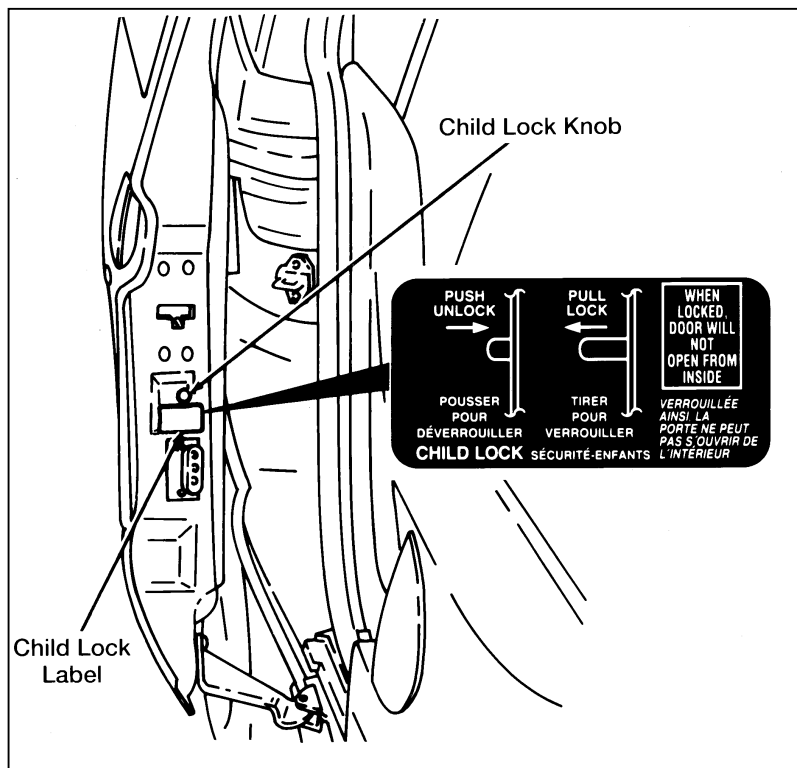

Childproof lock location

To set the childproof lock:

1. Open the sliding door.
2. Find the childproof lock knob above the label.
3. Pull the knob out.

To release the childproof lock:

1. Open the sliding door from the outside.
2. Push the childproof lock knob in.

Power Door Locks (If equipped)

The power door lock control switches are located in the panels of the front doors. They control the locks on both front doors, the sliding door and the liftgate.

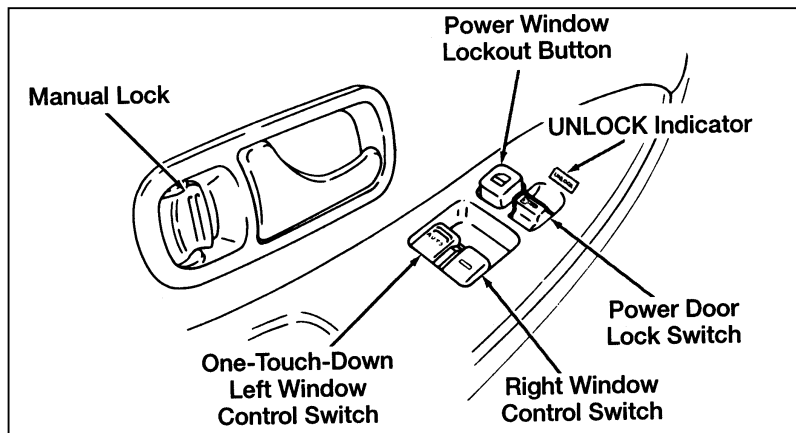

The power door lock switch

NOTE: If the sliding door is open when all doors are locked with the power door lock switch, the sliding door automatically locks when it is closed.

You can manually lock and unlock the doors using the manual door locks to override the power locks.

Keyless Entry System (If equipped)

If you have chosen the keyless entry system option for your vehicle, you can lock or unlock the doors and liftgate without using a key. The keypad is above the outside door handle on the driver's side. You can also use it to arm or disarm the anti-theft system (if equipped). For more information on the anti-theft system, refer to the Index.

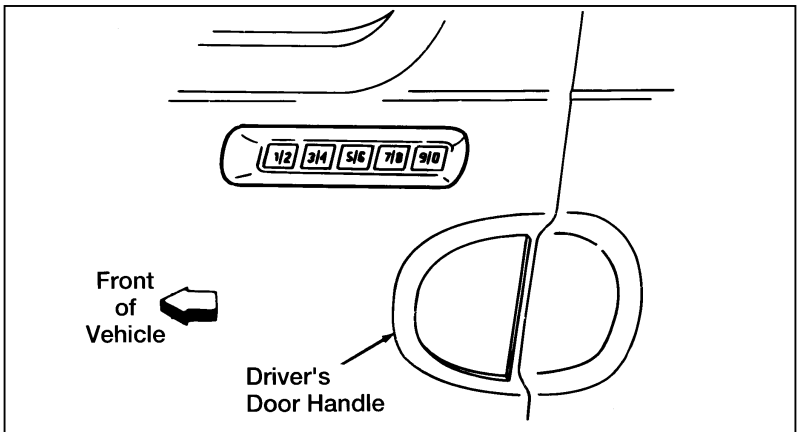

The keyless entry system keypad

The keypad will light when you push any of its buttons. In addition, pushing any of the buttons will also activate the illuminated entry system. For more information on the illuminated entry system, refer to the Index.

Do not push the keypad buttons with a key, ball-point pen, pencil, or any other hard object since they could damage the buttons.

Using the Keyless Entry System

To operate the Keyless Entry System, you must be familiar with the “personal code” and the “permanent code.” The personal code is a code number that you select that is easy for you to remember. This is the number that you enter on the keypad to unlock the door. The personal code can be changed as often as you like.

The permanent code is a number that is assigned to your vehicle. It does not unlock the door but is used to program your personal code into the system. Once you have programmed your personal code you will not need the permanent code again until you wish to change your personal code.

The permanent code is taped to the computer module behind the center console of your vehicle. It is also taped to your Keyless Entry System Owner’s Card. For your convenience, three additional pieces of tape with the permanent code have been included in the glove box. Place these additional pieces of tape in safe locations where you can refer to them when necessary. Do not put them in any location that is accessible to unauthorized persons, since this would allow them entrance to your vehicle.

Valid and Invalid Codes

To help protect your vehicle from theft, certain codes that are easily figured out cannot be registered for your personal code. Some of the codes that cannot be registered for your personal code include: the permanent code, five numbers consisting of the same button, five consecutive numbers and a sequential combination of numbers. The keyless entry system reads 1/2 and 9/0 as sequential numbers.

The following numbers cannot be entered as a personal code:

- Any number containing digits that are all on the same button. Example: 2-1-2-1-2
- Any number requiring sequential operation of the buttons. Example: 1-3-5-7-0 or 7-5-3-1-9
- Any number with fewer than five digits or more than five digits.

Programming your Personal Code

To program your own code:

1. Enter the permanent code.
2. A buzzer will sound for about six seconds or until your five-digit personal code is entered.
3. If you have programmed a valid number within five seconds of entering the permanent code, the buzzer will sound for about two seconds and the keypad light will shut off.
4. Test your personal code to see if it has properly registered. If it registered, any previously entered personal code has been erased from memory.
5. If you have successfully entered your personal code, the driver's door will unlock.

If the personal code you entered did not work, it may be that you entered an invalid personal code. See *Valid and Invalid Codes* in the previous section to select a valid personal code.

NOTE: If the battery is ever disconnected, the permanent code and your personal code will be retained in memory.

Changing Your Personal Code

To change your personal code, simply repeat the steps for entering your personal code using a new series of numbers; the previous personal code will be erased and replaced by the new code.

Unlocking the Doors with the Keyless Entry System

To unlock the driver's door, simply enter your personal code.

To unlock the passenger's door and the sliding door, enter your personal code and press the 3/4 button within five seconds.

To unlock the liftgate, press the 5/6 button within five seconds of unlocking the driver's door.

Locking the Doors

To lock all of the doors, press the 7/8 and 9/10 buttons at the same time. To prevent you from locking your keys in your vehicle, this feature will not operate if the key is in the ignition. It also will not operate if the front doors, sliding door or the liftgate are open.

Illuminated Entry System (Available with Keyless Entry System)

Refer to *Entry system, illuminated* in the Index for details.

Remote Keyless Entry System (If equipped)

Your vehicle may be equipped with a remote keyless entry system. This option will allow you to open your vehicle using a remote transmitter from distances of up to 49 feet (15 meters) away. The remote feature will operate only when the ignition is in the OFF position.

The transmitter can unlock the driver's door, unlock all doors, lock all doors, and activate the vehicle's anti-theft system (if equipped).

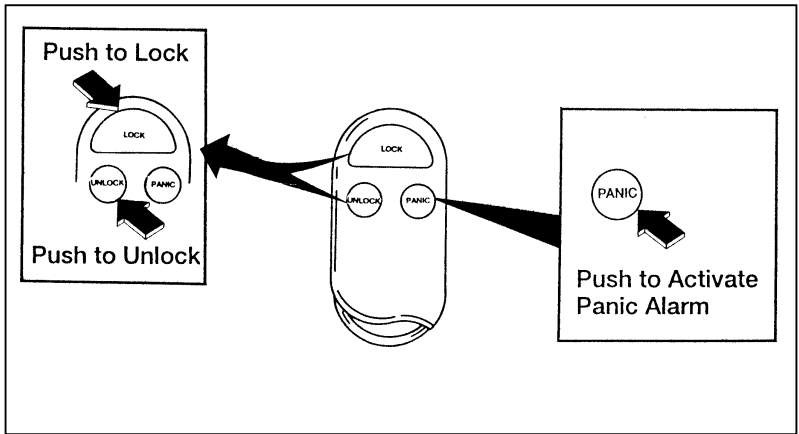

Remote keyless entry transmitter

By pressing the UNLOCK button on the transmitter once, you can unlock the driver side door. Pressing the UNLOCK button a second time within six (6) seconds of unlocking the driver's door will unlock the other doors. The interior lamp will turn on and stay on for thirty (30) seconds.

By pressing the LOCK button on the transmitter once, all the doors will lock, the parking lamps flash twice and the horn chirps. When the LOCK button is pushed with all the doors locked, the parking lamps flash twice and the horn chirps to confirm that the doors are already locked.

Using the Panic Alarm

If you are near your vehicle and feel threatened, you may activate the alarm to call attention to it.

To activate the PANIC alarm, push and hold the PANIC button on the remote for longer than 1.5 seconds. The horn will sound and the headlamps and tail lights will flash for thirty (30) seconds. To turn off the alarm, press the LOCK or UNLOCK buttons or hold the PANIC button down for longer than 1.5 seconds.

Replacing the batteries

The remote entry transmitter is powered by two coin type Sanyo CR2016 3 volt batteries (included). If you notice a significant decrease in operating range, the batteries should be replaced. Replacement batteries can be purchased at most pharmacies, watch stores or at your Ford or Lincoln-Mercury dealer.

NOTE: The operating range of the remote entry system can also be affected by weather conditions (such as very cold temperatures) or structures around the vehicle (buildings, other vehicles, radio and TV towers, etc.). Typical operating range will allow you to be up to 49 feet (15 meters) away from your vehicle.

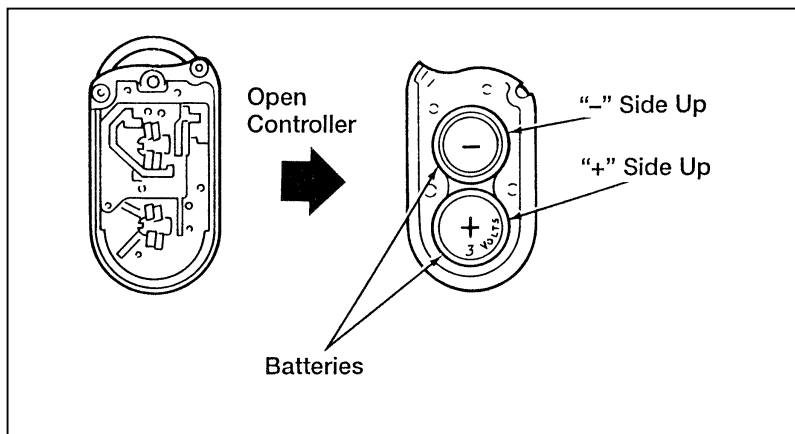

Replacing the batteries

Remove the two batteries by snapping open the lid of the remote transmitter. Replace the batteries with new ones as shown in the above illustration. Close the lid securely. Press both the LOCK and the UNLOCK button two or three times to test the remote transmitter operation.

If the batteries are removed for any reason other than replacement, repeat the steps in *Replacing the batteries* to test your remote transmitter(s).

- An improperly disposed battery can hurt the environment. Always confirm local regulations for battery disposal.
- The remote transmitter is waterproof; however, if it does get wet, immediately wipe it completely dry.
- The operational range of the remote transmitter extends to approximately 49 feet (15 meters) from the vehicle. This range may vary with conditions.

THIS DEVICE COMPLIES WITH PART 15 OF THE FCC RULES. OPERATION IS SUBJECT TO THE FOLLOWING TWO CONDITIONS: (1) THIS DEVICE MAY NOT CAUSE HARMFUL INTERFERENCE, AND (2) THIS DEVICE MUST ACCEPT ANY INTERFERENCE RECEIVED, INCLUDING INTERFERENCE THAT MAY CAUSE UNDESIRE OPERATION.

Replacement/Additional Transmitters

In the event a transmitter is lost or an additional remote transmitter needs to be set, you must change the ID code. Follow the steps below to change the ID code of your system, or return the remaining transmitter(s) to your dealer for reprogramming of your remote entry system. This is necessary to prevent unauthorized use of the lost transmitter.

ID Code Programming Procedure

NOTE: All transmitters must be programmed (or reprogrammed) at the same time. If the programming mode is entered and the transmitters are not programmed (or reprogrammed) at the same time, they will not operate with the system.

1. Enter vehicle and close and lock all doors.

-
2. Insert and remove key from ignition six times within ten (10) seconds. The instrument panel lights will flash twice.
 3. Turn ignition key to the ACC position.
 4. Press the LOCK button on the remote transmitter once.
 5. To enter additional remote controllers (including the original), unlock, then lock the driver's door using the power door lock switch.
 6. Press the LOCK button on a new remote transmitter. The instrument panel lights will flash twice, indicating code is entered.
 7. Repeat steps 5 and 6 as needed (up to four remote transmitters may be programmed).

Anti-Theft System (If equipped)

This system helps protect your vehicle against break-ins or theft by monitoring all doors and the liftgate lock cylinder.

When an unauthorized entry occurs, the system triggers and will:

- flash the headlamps and hazard lamps
- honk the horn
- disable the starting circuit to prevent the vehicle from being started

To arm the system

1. Remove the key from the ignition.
2. Lock the doors by using either the power door lock switch or by turning the key in either the driver or passenger door lock cylinder. The parking lights will flash and the horn chirps to let you know that the system has been armed. The anti-theft indicator light on the right side of the steering wheel will light and remain on.

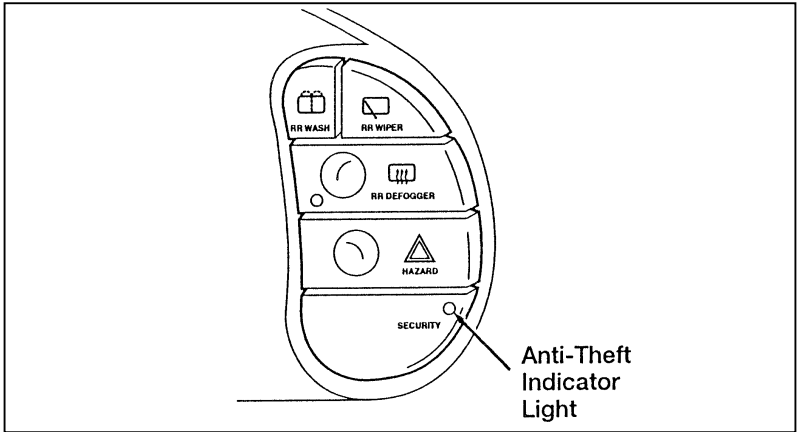

Anti-theft indicator light

NOTE: If your vehicle is equipped with a factory installed keyless entry system or remote keyless entry system (or both), the system can be armed by closing all the doors and pressing the LOCK button on the remote transmitter or by pressing the 7/8 and 9/10 buttons on the keyless entry keypad.

3. Close all doors. The anti-theft indicator light will stay on for approximately 30 seconds and then flash once every 2.5 seconds.

NOTE: Be sure to close all the doors completely. If the doors are not completely closed, the alarm indicator light will remain on steadily. The anti-theft system is armed only when the anti-theft indicator light remains on steadily for approximately 30 seconds after the last door is closed, and then flashes every 2.5 seconds.

Disarming an untriggered anti-theft system

Unlock either door with the door key or by pressing the UNLOCK button on the remote keyless entry transmitter (if equipped) or by entering your personal code on the keyless entry keypad (if equipped). This will disarm the system. When you unlock the door with the key, make sure you fully rotate the key in the lock. If you do not, the system may not disarm, and will trigger when a door is opened.

If the system is armed and you remain in your vehicle, simply insert the key into the ignition and turn it to ACC. This disarms the system and allows you to open the door to exit without triggering the system. Remember to rearm the system by using the power door lock, the remote transmitter (if equipped), or the keyless entry keypad (if equipped) to lock the doors.

The remote keyless entry system is designed to work with the factory installed anti-theft system. It may not work with other anti-theft systems.

Triggering the anti-theft system

The armed system will be triggered if:

- any door is opened without using the door key, the keyless entry keypad (if equipped), or the remote keyless entry transmitter (if equipped)
- the liftgate is opened or unlocked
- the hood is opened

Disarming a triggered anti-theft system

The alarm can be disarmed by using one of the following methods:

- unlocking the driver or passenger doors
- unlocking the doors using the keyless entry keypad (if equipped) or with the remote keyless entry transmitter (if equipped)
- putting the key in the ignition and turning it to the ACC position

NOTE: The flashing lights and honking horn will shut off automatically within 2 minutes 30 seconds after the system is triggered. It will trigger again if another intrusion occurs. However, the starter circuit remains disabled until the system is disarmed.

NOTE: Both remote keyless entry systems will only operate with the ignition in the OFF position.

Liftgate

Opening the Liftgate

To unlock the liftgate with the key, insert the key into the lock and turn it counterclockwise. To make the gate swing up to the fully opened position, pull back and upward on the handle. The liftgate will not unlock if the optional liftgate window is open.

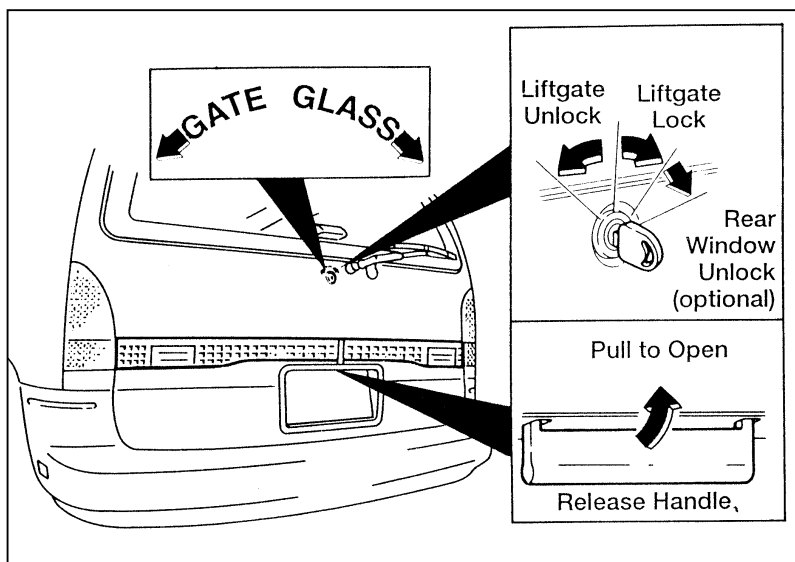

Opening the liftgate

You can also unlock the liftgate using the optional power door lock system, or the optional keyless entry system. However, it cannot be opened until you release the latch by reaching under the license plate light shield and lifting up on the handle.

Opening the Liftgate Window (If equipped)

To open the liftgate window only, turn the key clockwise. The window unlatches and the rear wiper falls out of the way. Do not force the wiper down by hand — it moves when the key is turned. To close, push downward until it latches.

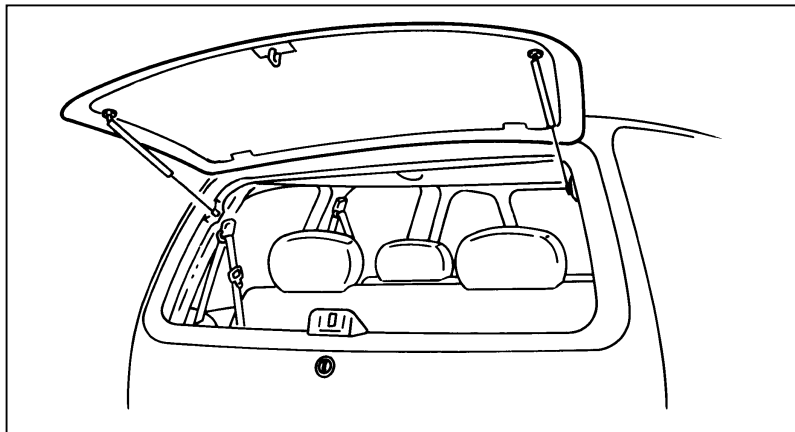

The liftgate window in the open position

WARNING

Never drive the vehicle with the liftgate window open. Dangerous exhaust fumes can be drawn into the vehicle with the window raised and the vehicle moving.

Closing the Liftgate

To close the liftgate, reach up and pull the handle on the inner trim panel downward.

When you have pulled down the liftgate enough so that you can reach the license plate light shield, push the shield down and forward to close the liftgate. At this point, the liftgate is not locked.

The liftgate has an intermediate and a fully closed position. Make sure the liftgate is fully closed before you drive your vehicle.

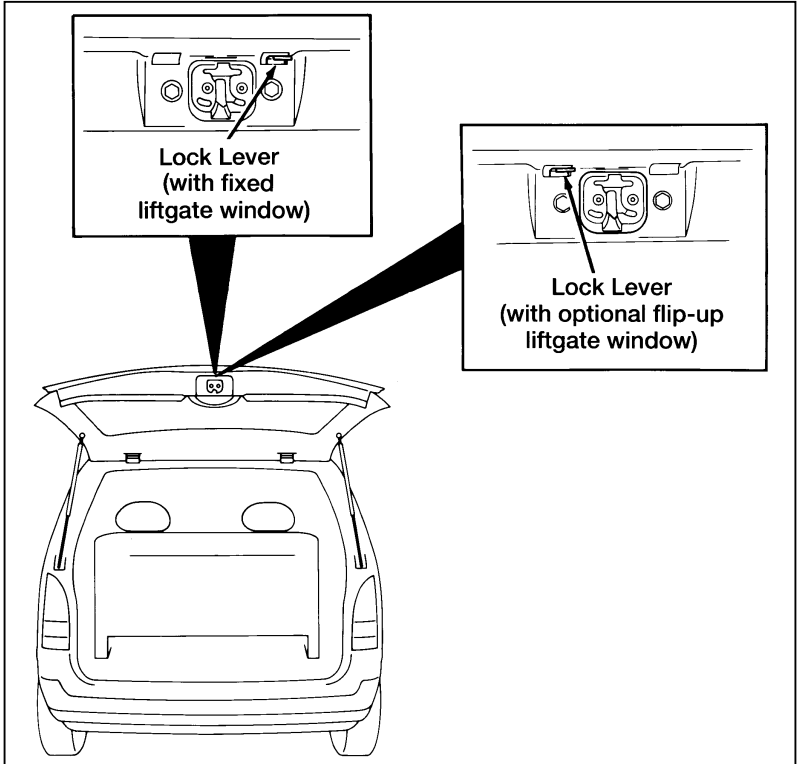

Locking the liftgate using the lock lever

You can lock the liftgate by pushing in the lock lever before you begin to close the liftgate. You can also lock the liftgate by closing the liftgate, inserting your key and turning it clockwise until you hear the lock lever engage. If you turn it too far, the optional liftgate window will open. The liftgate can also be locked with the optional power door locks.

The liftgate area is intended only for cargo, not passengers. It cannot be opened from inside the vehicle.

After the lock lever is depressed, the liftgate must be unlocked with the power door lock button or the key.

NOTE: The lock lever will be on the right side of the lock cylinder if your vehicle is equipped with the standard liftgate glass. The lock lever will be on the left side of the lock cylinder if your vehicle is equipped with the optional flip-up liftgate window.

Windows

Power Windows (If equipped)

Each of the front doors has a power control that opens and closes the window on that door. The driver's door has master controls that operate both front door windows. You must place the ignition in the ON position to use your power window controls. The driver's power window controls include a lockout button which prevents the operation of the passenger side window from either the passenger or driver side controls.

To open the window, press down on the switch; to close the window, lift up on the switch.

 WARNING
Do not let children play with the power windows. They may seriously hurt themselves. Make sure occupants are clear of the window(s) before closing.

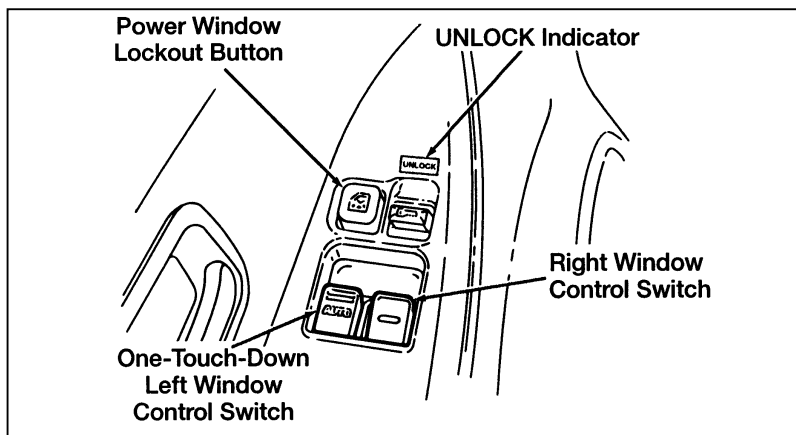

Driver side power window controls

One-Touch-Down Power Window (Included with optional power windows — driver side only)

The one-touch-down power window feature allows you to completely open the driver's window without holding down the window switch. To open the window completely, press the switch down for about one second, then release it. If the switch is momentarily lifted while the window is going down, the window will stop at that position.

To close the window you must lift and hold the switch until the window closes.

Manual Flip-Open Quarter Windows

To open the flip-open quarter windows in the second or third row, pull the rear portion of the latch toward you. Swing the latch forward and out, then lock it into the open position by pushing rearward until you hear a snap. To close the windows, reverse the procedure.

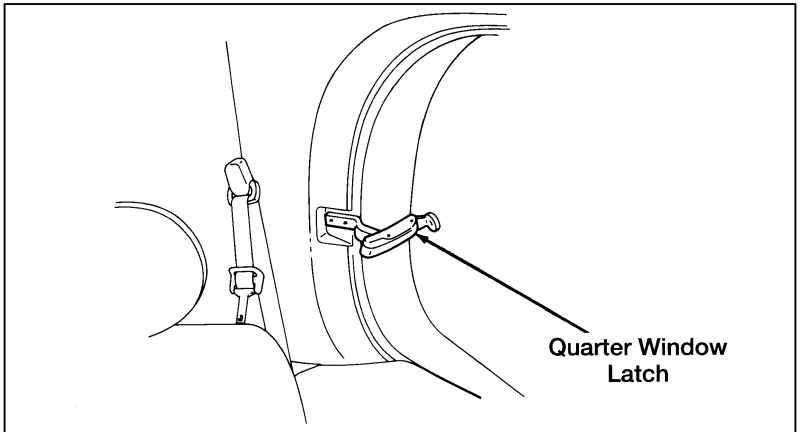

Manual flip-open quarter window latch location

NOTE: Optional third-row power windows must be opened with the overhead console controls.

Power Quarter Windows (If equipped)

The power quarter windows operate with the ignition in the ON position. The power-operated quarter windows in the third seat position are controlled by the RIGHT VENT and LEFT VENT switches on the overhead console. Press the indented side of the switch to open the windows; press the raised side of the switch to close the windows.

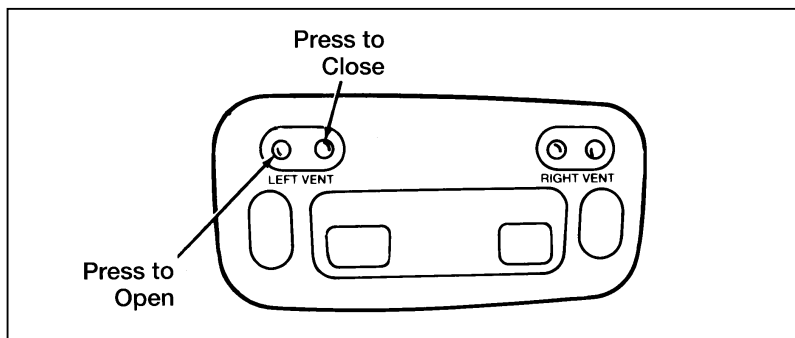

Power quarter window switch

Power Sunroof (If equipped)

The power sunroof controls are found in the overhead console. The power sunroof operates with the ignition in the ON position.

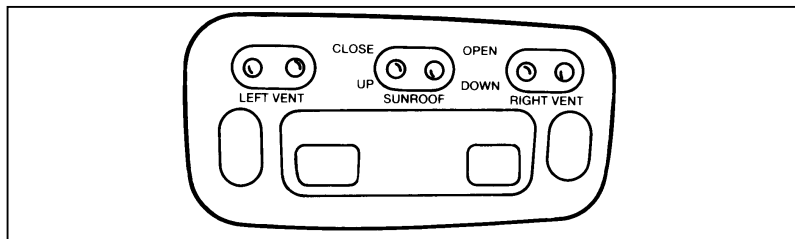

Power sunroof controls

To open the sunroof, press and hold the OPEN side of the switch. Release the switch when the sunroof reaches the desired position. To close the sunroof, press the CLOSE side of the switch.

When the sunroof panel is closed, you can raise the sunroof to the vent position by pressing the UP side of the switch. To lower the sunroof from the vent position, press the DOWN side of the switch.

 WARNING
--

Do not let children play with the sunroof. They may seriously hurt themselves.

Remove any snow, water or other foreign matter from the sunroof before you open it.

Sliding Shade

The sunroof has a sliding shade you can manually open or close to block the sun when the glass panel is shut. To close the sliding shade, pull the shade toward the front of the vehicle. The shade automatically opens when the sunroof is opened.

Seats

Head Restraints

If you use them properly, head restraints will help protect your head and neck in a collision.

The head restraints can be adjusted in four positions: fully raised, fully lowered and two intermediate positions. Press down on the head restraint adjustment button and move the restraint to the position that places the restraint directly behind your head.

A head restraint helps protect you best if you position it behind your head and not behind your neck.

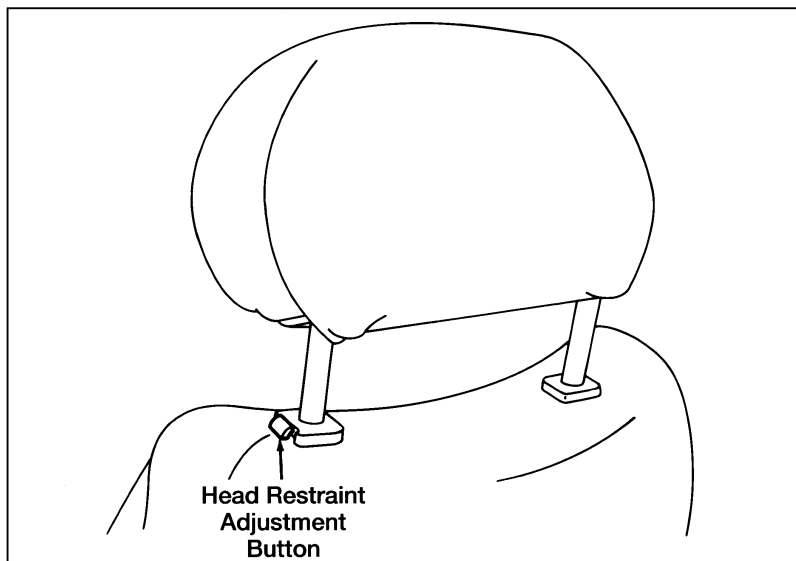

The adjustable head restraint

For more information on the seats in your vehicle, see the *Adjustable Rear Seating* chapter in this owner guide.

Adjusting the Front Seats Manually

If you have manually adjustable front seats, you can move your seat to a new position by lifting up on the seat adjustment lever and sliding the seat to the position of your choice. The lever is underneath the front of your seat.

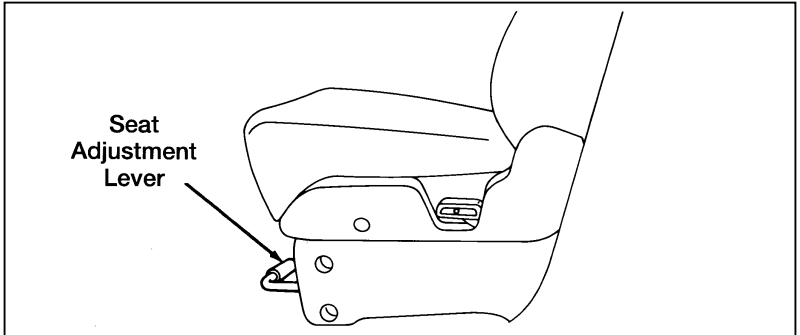

Seat adjustment lever location

⚠ WARNING

Never adjust the driver's seat or seatback when the vehicle is moving.

⚠ WARNING

Luggage or other cargo should not be piled higher than the seatbacks. Items can be thrown about and injure people in an accident or sudden stop.

Reclining Seats

You can tilt back the seats in your vehicle.

WARNING

All passengers riding in your vehicle should keep their seatbacks in the upright position. Lap belts should be snug and low across the hips. Failure to follow these precautions can increase the risk of injury to the abdomen and neck resulting from sliding under the safety belts in a collision.

To recline the seatbacks:

1. Lift up the release lever and hold it up while you lean against the back of the seat.
2. When the seatback is tilted to the position you chose, release the lever to lock the seatback in place.
3. To return the seatback to its upright position, lift the lever and lean forward.

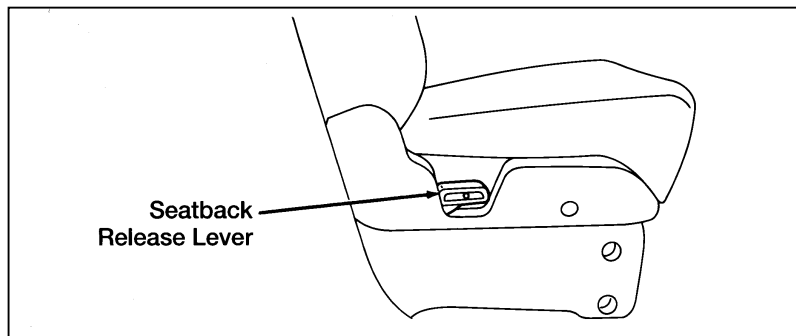

Seatback release lever location

Using Power Seats (If equipped)

If your vehicle has power front seats, you can adjust your seat in several directions. The driver's seat can be adjusted in six directions and the passenger's seat can be adjusted in four directions. The controls are located on the side of the seat closest to the door. The seat can be adjusted even without the key in the ignition.

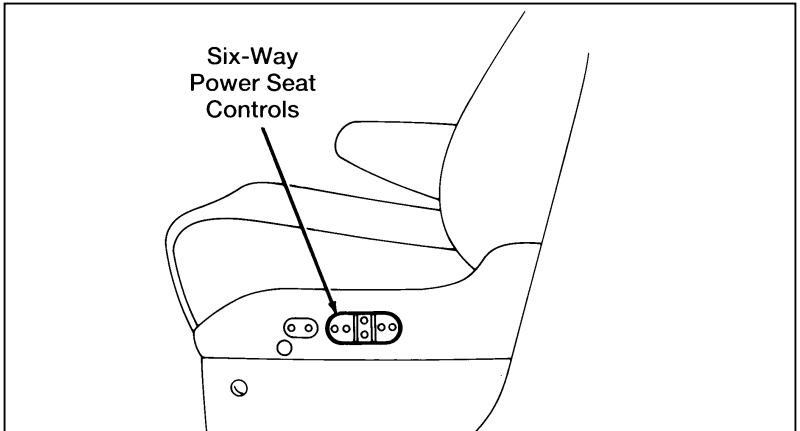

Six-way power seat controls location

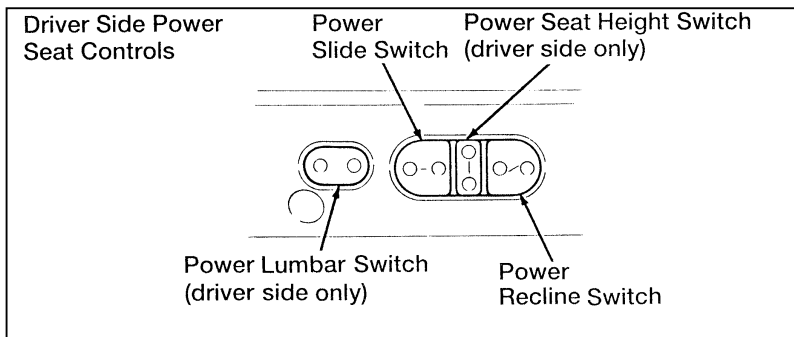

Six-way power seat controls

Power Lumbar Support (If equipped — driver's seat)

The controls for the driver's seat power lumbar support are on the side of the seat next to the door. This feature provides built-in support for the driver's lower back.

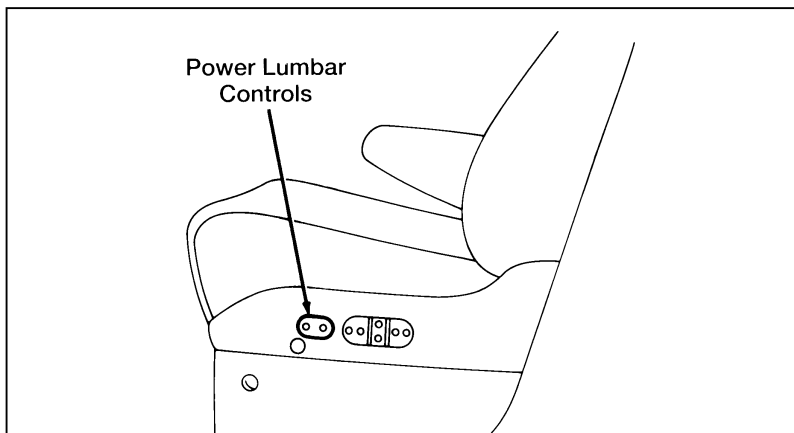

Power lumbar support controls location

To inflate the lumbar support pad, push the raised end of the switch. To deflate the lumbar support pad, push the indented end of the switch.

Cleaning the Seats

Leather

For routine cleaning, wipe the surface with a soft, damp cloth. For more thorough cleaning, wipe the surface with a leather and vinyl cleaner or a mild soap.

Fabric

Remove dust and loose dirt with a whisk broom or a vacuum cleaner. Remove fresh spots immediately. Follow the directions that come with the cleaner.

NOTE: Before using any cleaner, test it on a small, hidden area of fabric. If the fabric's color or texture is adversely affected by a particular cleaner, do not use it.

Storage Compartments

Underseat Storage Compartment (If equipped)

The underseat storage compartment is located underneath the front passenger seat. It can be opened by pulling it toward the instrument panel.

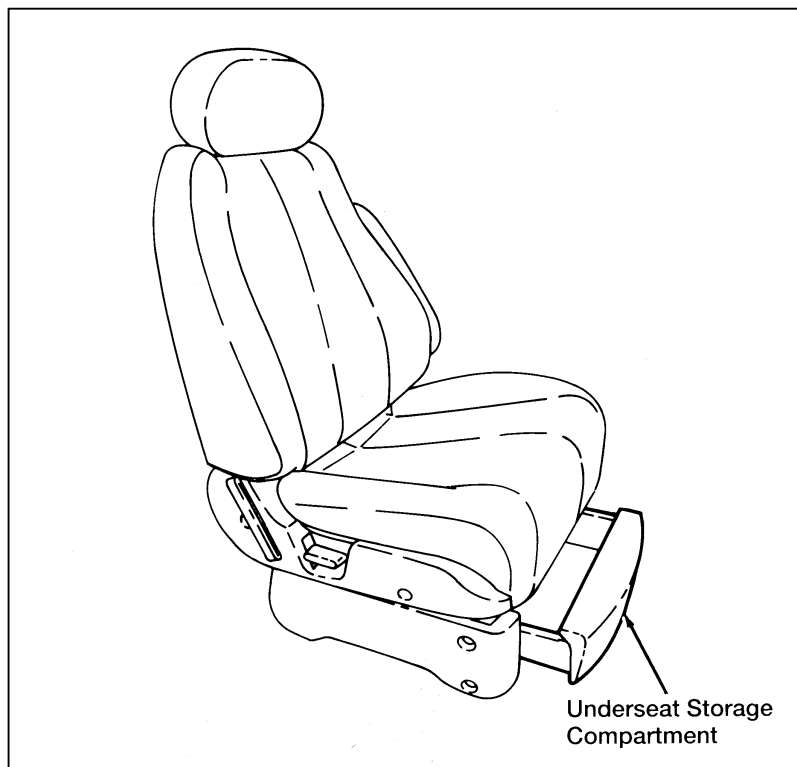

The underseat storage compartment

Coin Tray

The slide-out coin tray is located in the instrument panel for your convenience. It is located below the radio controls.

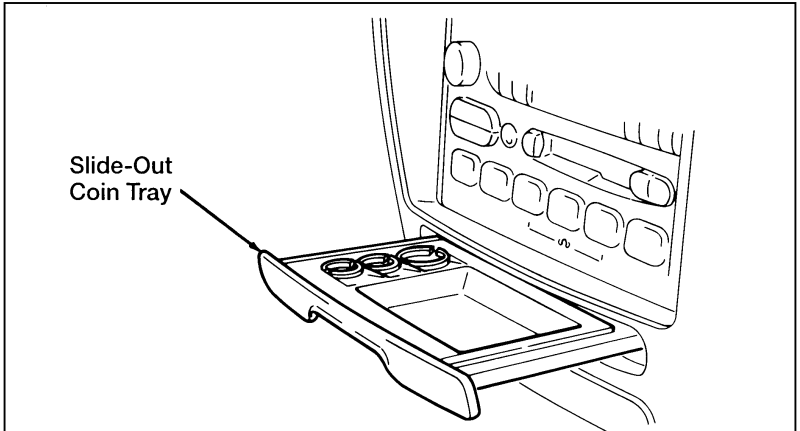

Coin tray

Front Seat Cupholders

The front seat cupholders are located on the side of the passenger's seat. Find the indented ledge and pull it down, away from the side of the seat, toward the driver's seat. When the cupholder is not in use, push the cupholders into the cover and lift the cover into its fully stored position.

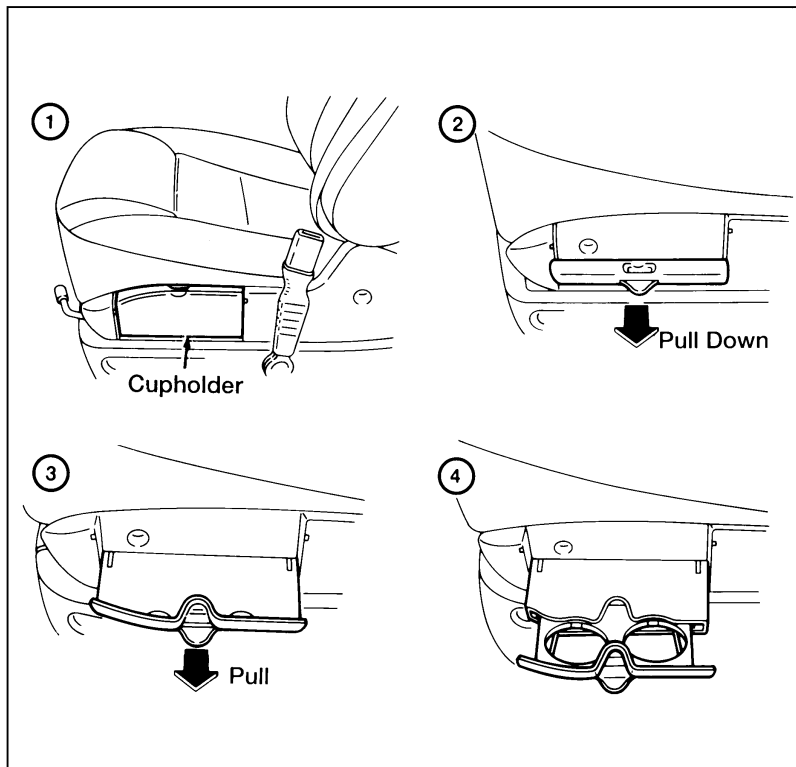

Using the front seat cupholders

NOTE: Do not place heavy objects in the cupholders.

Rear Seat Cupholders (available on some models)

Your vehicle may also have rear seat cupholders built into the side panels.

 WARNING
--

<p>Objects stored on the ledges below the rear side windows can become dangerous projectiles during a sudden stop or collision. Put small objects only in the storage compartments.</p>
--

Third Row Seat Storage Compartment (If equipped)

Your vehicle may come equipped with a folding cupholder/storage tray/storage compartment built into the passenger's side of the third row seat. Find the indented ledge on the right of the cupholder and pull it up to reveal the storage compartment.

Power Point Electrical Outlet (If equipped)

Your vehicle may be equipped with a 12 volt power point outlet located just below the rear seat audio controls. The power point can be used in place of the cigarette lighter for optional electrical accessories.

NOTE: Do not plug the cigarette lighter into the power point electrical outlet. Use the cigarette lighter.

Mirrors

 WARNING
--

<p>Make sure you can see clearly through the rearview mirror at all times. Do not allow anything to block your vision. If you can't see through the mirror, you could be involved in an accident and injure yourself or others.</p>
--

Side View Mirrors

Close your door and adjust the driver's seat to the most comfortable position before you adjust the side view mirrors.

NOTE: Be careful. The convex side view mirror on the right makes objects appear smaller and farther away than they actually are. Use the inside rearview mirror (or look behind you) to determine the actual size and distance of objects that appear in the convex mirror.

Dual Electric Remote Controlled Mirrors (If equipped)

If you have power side view mirrors, you can adjust them in any direction by using the mirror controls on the instrument panel. This switch operates with the ignition in ON or ACC.

The mirror control switch is on the instrument panel to the left of the steering wheel.

To adjust the remote controlled side mirrors:

1. Select the right or left mirror by rotating the selector switch to R or L.
2. Move the control knob in the direction you want to move the mirror.
3. Return the selector switch to the middle position to keep the mirror in place.

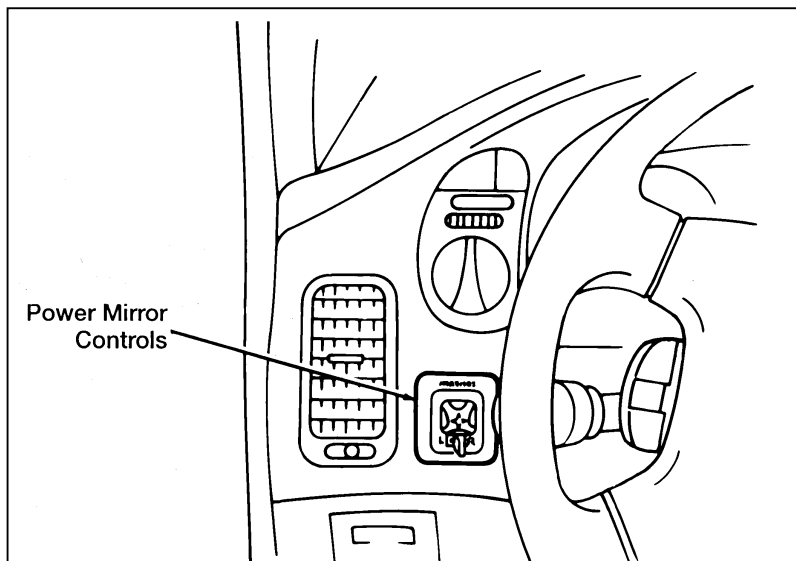

Dual electric remote controlled mirrors switch

Heated mirror feature (if equipped)

Both power mirrors are heated whenever the rear window defroster is turned on. Do not remove ice from the mirrors with a scraper or you could damage them.

Cargo Net (If equipped)

The cargo net is designed to hold your cargo upright between the third row bench seat and the liftgate to prevent it from moving around the cargo area.

To install the cargo net:

Attach the loops on the four corners of the net to the four retainers on the cargo area rear quarter panels. Pull on the net to be sure that it is fastened securely.

⚠ WARNING

Be sure to secure all four loops into the retainers. The cargo restrained in the net must not exceed 50 lbs. (22.5 kg) or the net may not stay secured.

To remove the cargo net, remove the loops from the four retainers.

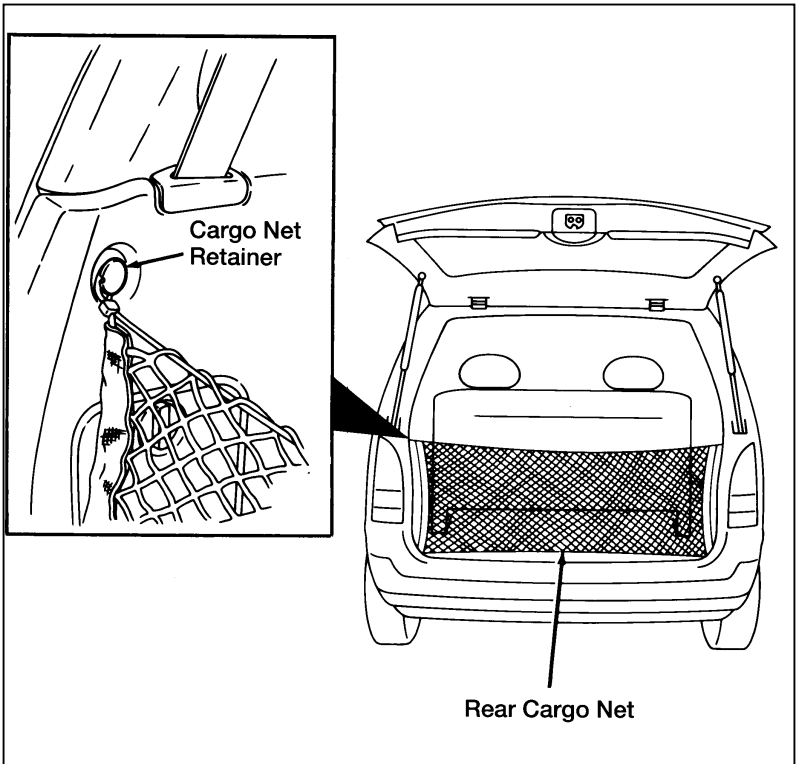

The rear cargo net

Four Season Roof Rack (If equipped)

Always load your luggage as far back as it will safely go on the four season roof rack. Do not load more than 100 pounds (45 kg). Be careful that your vehicle does not exceed the Gross Vehicle Weight Rating (GVWR) or its Gross Axle Weight Rating (GAWR front and rear). The GVWR and GAWR are located on the Safety Compliance Certification Label (located on the driver's door pillar).

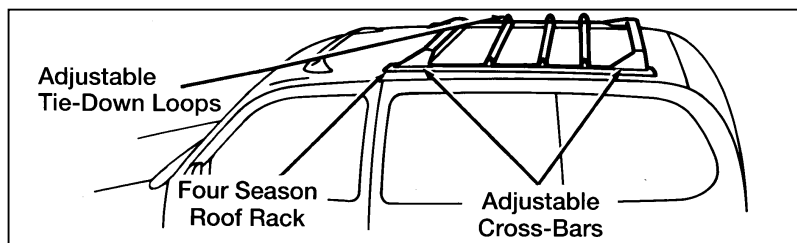

The four season roof rack

The front and rear cross-bars can be adjusted forward and backward. Place your luggage between the bars, adjust the bars, and secure the luggage with rope to the bars. There are also adjustable loops on the side bars for the rope attachment.

WARNING

Be sure that items on the roof rack are securely fastened.

Adjustable Rear Seating

The removable and adjustable seats are a convenient feature of your vehicle. Reading this chapter will help you learn about the various ways the seats in your vehicle can be arranged to suit your different needs.

Your vehicle is a five or seven-passenger vehicle. As a seven-passenger vehicle, it will have either a two-passenger bench seat or two second-row bucket seats and the sliding three-passenger bench seat in the third row. Read the section that describes the type of second-row seat in your vehicle. To make your vehicle a five-passenger vehicle, remove the second-row seats.

NOTE: When adjusting or moving any of the seats in your vehicle, do not use any of the buckles, tongues, or safety belt webbing to carry or move the seats. Lifting the seats by any of the safety restraint equipment could decrease their effectiveness.

NOTE: Your vehicle has five different kinds of floor mats: front seat mats, a cargo area mat, a sliding door area mat, and second and third row passenger area mats. Whenever you remove the mats to remove or adjust any of the seats always remember that the mats must be reinstalled before passengers ride in your vehicle. The floor mats are specifically designed to keep objects out of the seat tracks.

 WARNING
--

<p>It is important to replace the floor mats whenever they are removed for any reason. The floor mats are intended to help prevent the possibility that high-heeled shoes might become stuck in the seat tracks. Failure to replace the floor mats might result in personal injury.</p>
--

Floor Mats

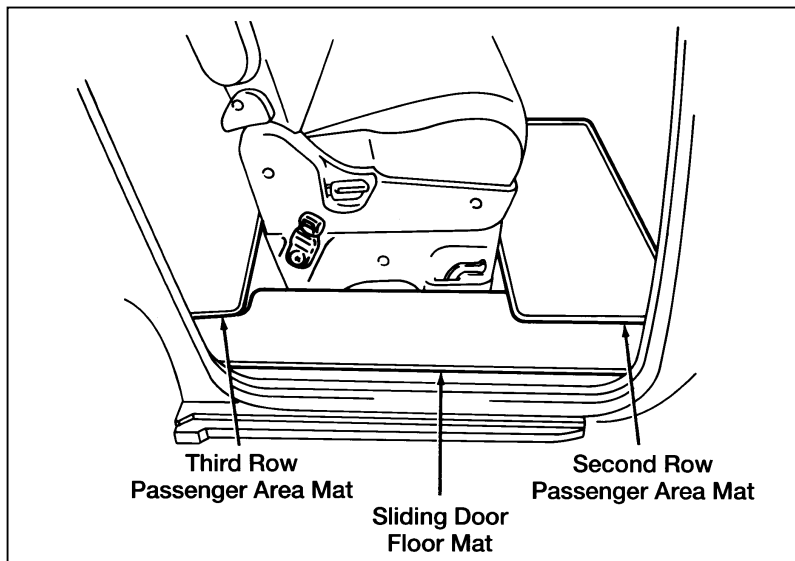

The removable floor mats

Removable Floor Mats

Whenever you remove the mats to remove or adjust any of the seats, always remember that the mats must be reinstalled before passengers ride in your vehicle. The floor mats are specifically designed to keep objects out of the seat tracks.

Be sure to keep the seat tracks clear of debris by cleaning them periodically.

Vacuum any particles from the inside of the tracks where the roller units are enclosed using a small crevice tool attached to a high-powered vacuum. This will ensure that the sliding seat will continue to slide properly during the life of your vehicle.

Adjustable Rear Seating

Review the following illustrations so you will know the proper way to place the floor mats with the various seating arrangements available in your vehicle.

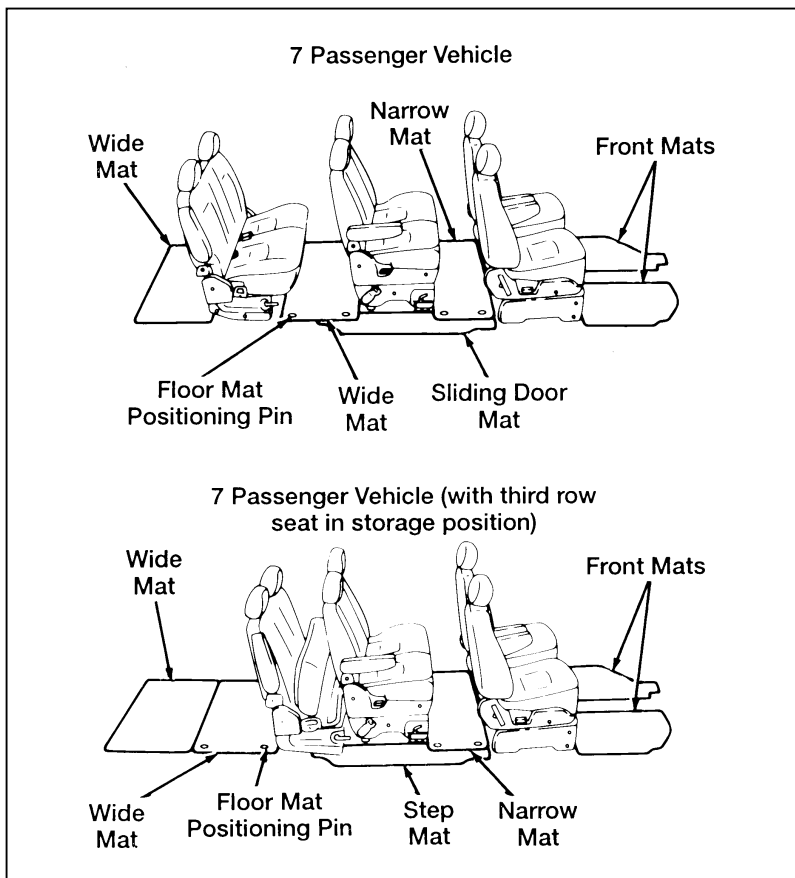

**5 passenger vehicle
(second row seats removed)**

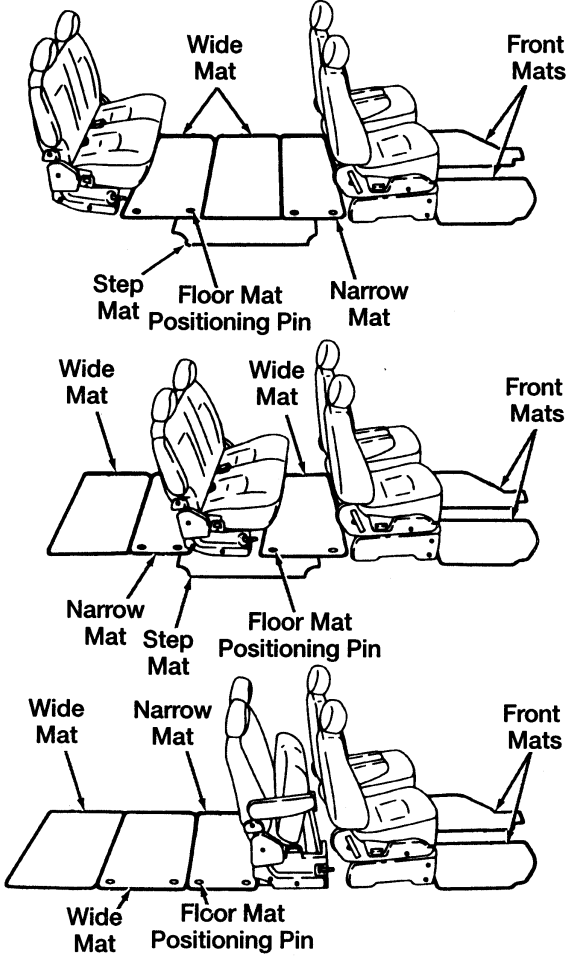

Adjustable Rear Seating

NOTE: The step mat should be placed neatly in the cargo area when not in use.

Positioning pins are included with your floor mats to secure them to the seat tracks. Push the positioning pins through the plastic loops in the floor mats and into the seat tracks.

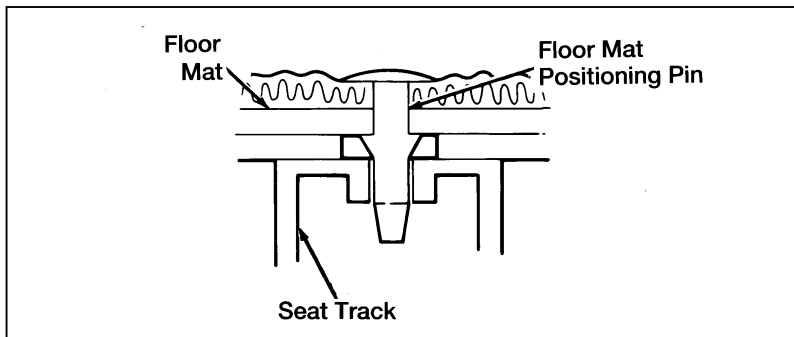

Floor mat positioning pin placement

NOTE: Be sure to keep the seat tracks clear of debris by cleaning them periodically with a high-powered vacuum.

Head Restraints

If you use them properly, head restraints are intended to help protect your head and neck in a collision.

The head restraints can be adjusted in four positions: fully raised, fully lowered and two intermediate positions. Press down on the head restraint adjustment button and move the restraint to the position that places the restraint directly behind your head.

A head restraint helps protect you best if you position it behind your head and not behind your neck.

NOTE: If your vehicle is equipped with the optional two-passenger bench seat with built-in child seats, the head restraints on the two-passenger bench seat are not adjustable.

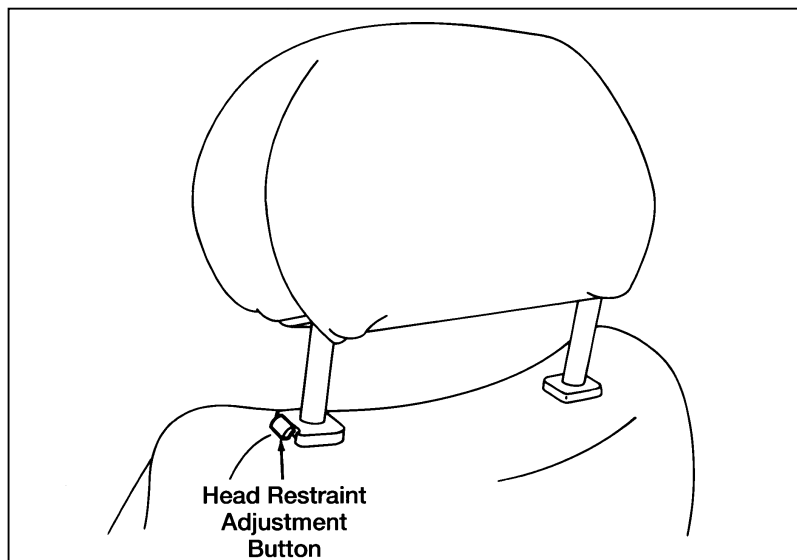

The adjustable head restraint

It is not necessary to remove the head restraints from the seats when removing seats from the vehicle. However, you can remove the head restraints by pressing the adjustment button at the base of the head restraint and pulling the head restraint upward. Remember to replace them when the seat is re-installed.

Adjustable Rear Seating

WARNING

The head restraints should be stored outside of the vehicle (with the removed seat) to prevent them from damaging the vehicle or injuring passengers in the case of sudden braking or a collision.

Two-Passenger Bench Seat

NOTE: The two-passenger bench seat has a unique safety restraint system. If your vehicle has the two-passenger bench seat it is very important that the unique safety belt system is used properly. Please read the section in the *Safety Restraints* chapter that explains the unique safety belt system and be sure you understand it before anyone rides in the two-passenger bench seat.

If your vehicle has the second row two-passenger bench seat, you can remove it if you need extra cargo space. With the second-row seat removed, the third-row bench seat can be moved up to a second-row seating or storage position for additional rear cargo area room.

To help prevent personal injury, at least two people are needed to remove the seat.

Removing the Two-Passenger Bench Seat

1. Remove the floor mats. Lift the seatback release lever and fold down the back of the seat to the fully folded position.

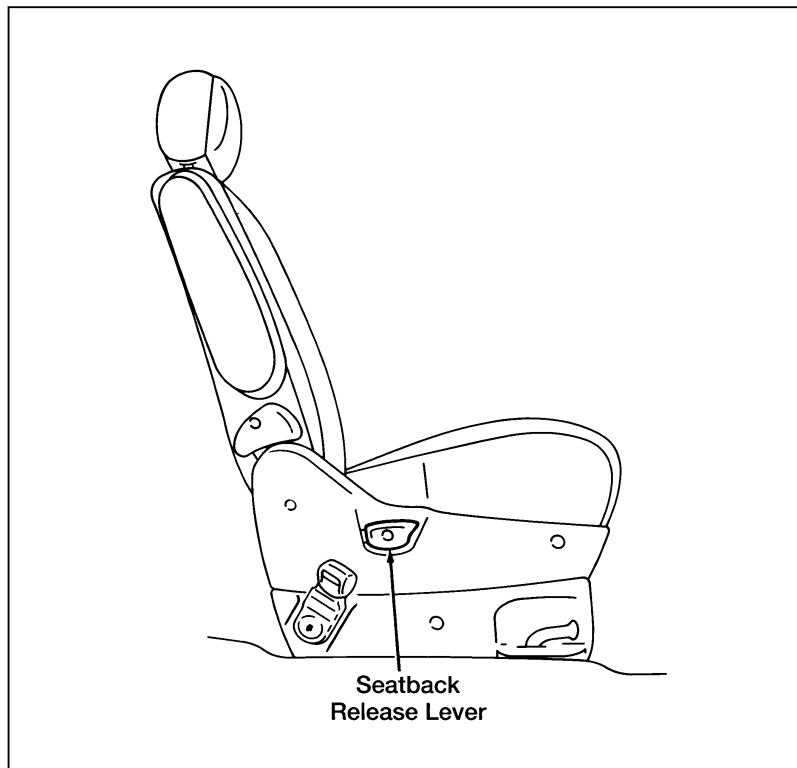

Seatback release lever location

2. Detach the tongue from the auxiliary buckle on the side of the seat.
3. Lift up on the floor latch levers near the front seat legs and release the seat legs from each anchor position.

Adjustable Rear Seating

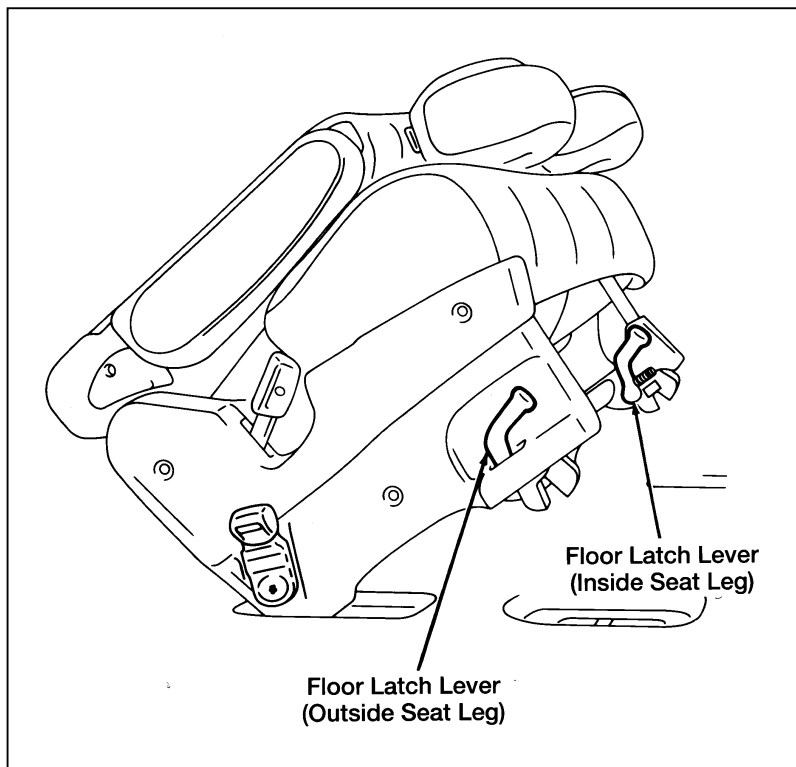

The floor latch levers

4. Place your hand under the seat cushion and tip the front of the seat upward slightly. Slide the seat rearward to release the seat from its anchor position.
5. Two people should lift the seat and remove it from the vehicle.
6. Replace any floor mats that were removed.

If you decide to move the three-passenger bench seat forward to the second row position, passengers riding in the seat will use the second row safety belts.

Installing the Two-Passenger Bench Seat

To replace the bench seat in its original position:

1. Make sure the area around the floor anchor positions is free from obstruction.
2. With the seatback folded down, two people should lift the seat into the vehicle.
3. Place the seat slightly behind the floor anchor positions and catch the rear leg anchors into each anchor position.
4. Press down on the front of the seat to secure the front legs to the two floor latch locks. Place the seatback in the upright position.
5. Try to move the seat to be sure that it is securely fastened.
6. Always reattach the tongue into the auxiliary buckle mounted to the side of the seat.

Labels have been provided on the side of the seat to remind you of important safety precautions.

7. Replace any floor mats that were removed.

 WARNING
--

Keep foreign objects out of the floor anchors. Objects in the floor anchors could prevent front and rear seat legs from engaging properly.

 WARNING
--

Before sitting in the removable seats, make sure that the seat legs are securely attached by the floor anchors.
--

Adjustable Rear Seating

WARNING

Never adjust the driver's seat or seatback when the vehicle is moving.

Bucket Seats (If equipped)

Quick-Release Bucket Seat

The quick-release bucket seat option allows the bucket seat nearest the sliding door to slide forward allowing easier entry and exit to the third-row seats. Pull up on the seat adjustment lever and slide the seat forward.

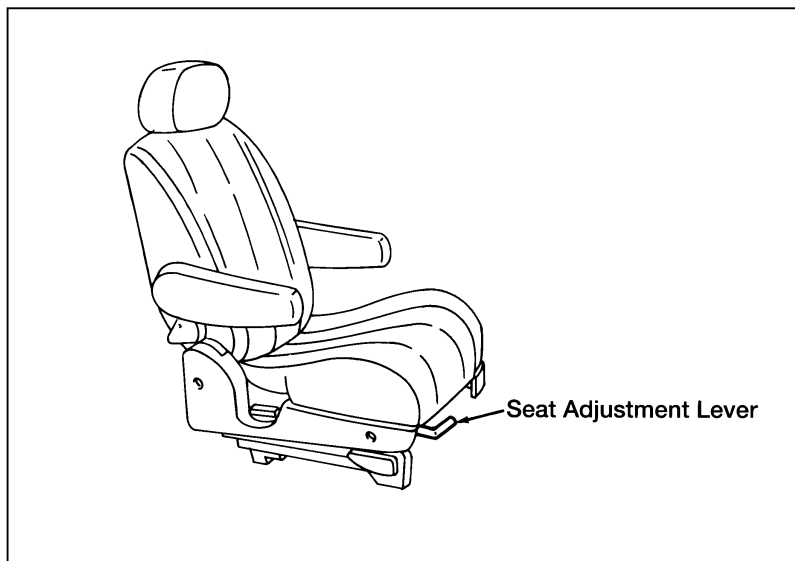

Seat adjustment lever location

The quick-release bucket seat also has two levers on the back of the seat — one to fold down the seatback and one to slide the seat forward. These levers allow third-row passengers to enter and exit more easily.

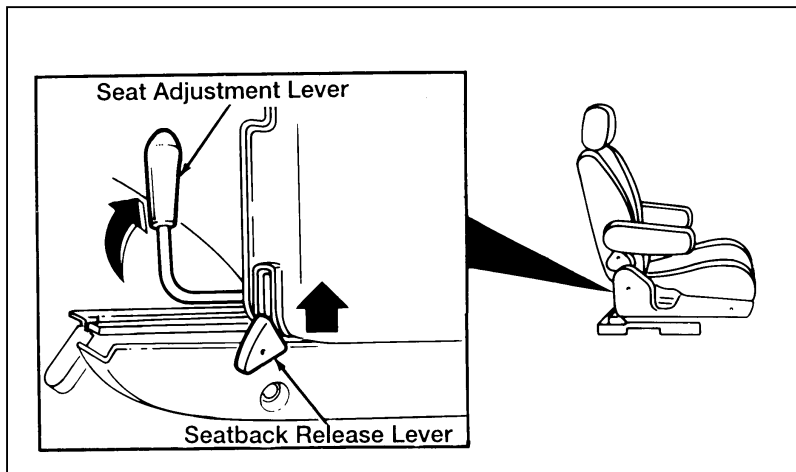

Quick-release bucket seat levers

Removable Bucket Seats

If your vehicle has second row bucket seats, you can remove them if you need extra cargo space. With the second-row seats removed, the third-row bench seat can be moved up to the second row position for additional rear cargo area room. When the third-row seat is moved to this position, passengers will use the second-row safety belts.

To help prevent personal injury, at least two people are needed to remove the seats.

Before you remove the seats, remove the floor mats. Then:

1. Pull the seatback release lever up and tilt the back of the seat forward as far as possible.

Adjustable Rear Seating

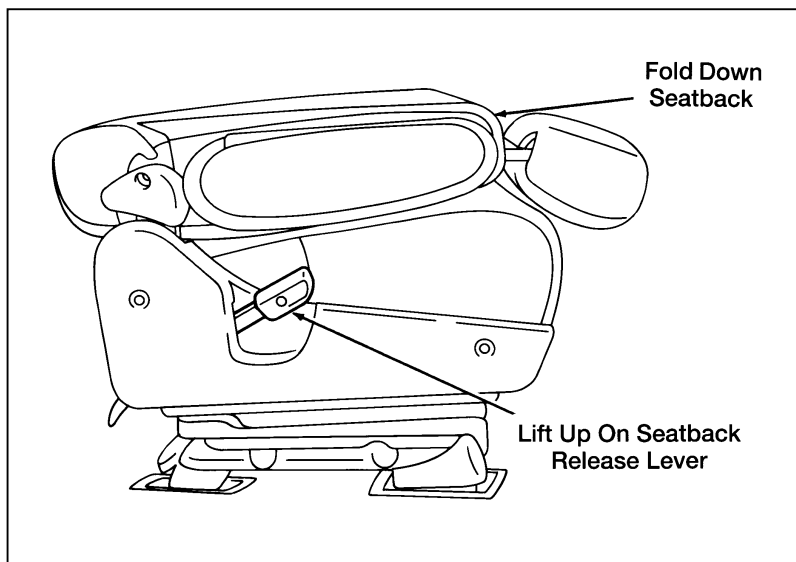

Folding down the seatback

2. Lift up on the two floor latch levers near the front seat legs and release the seat legs from each anchor position.

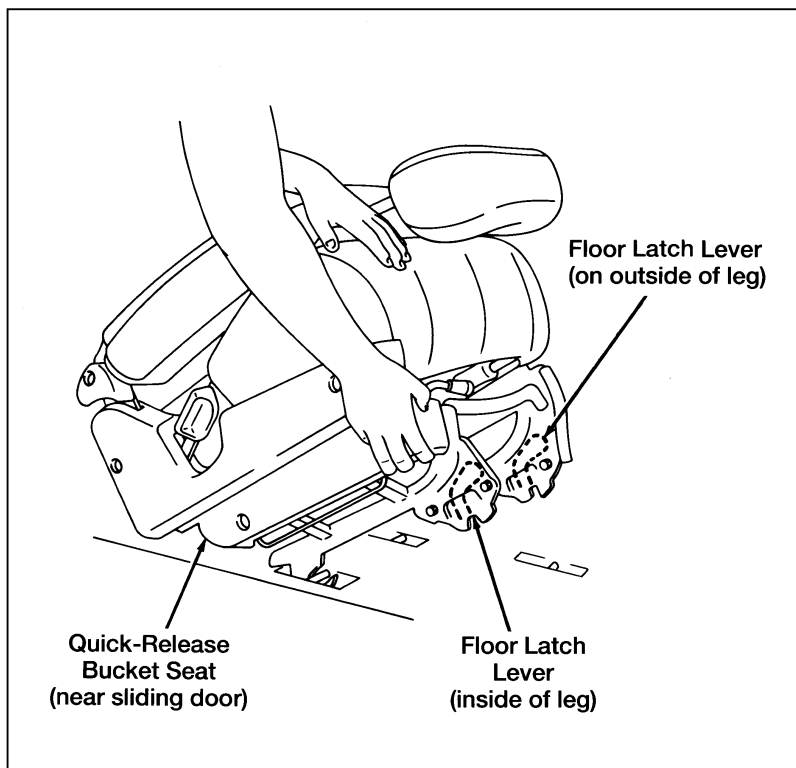

Removing the quick-release bucket seat

Adjustable Rear Seating

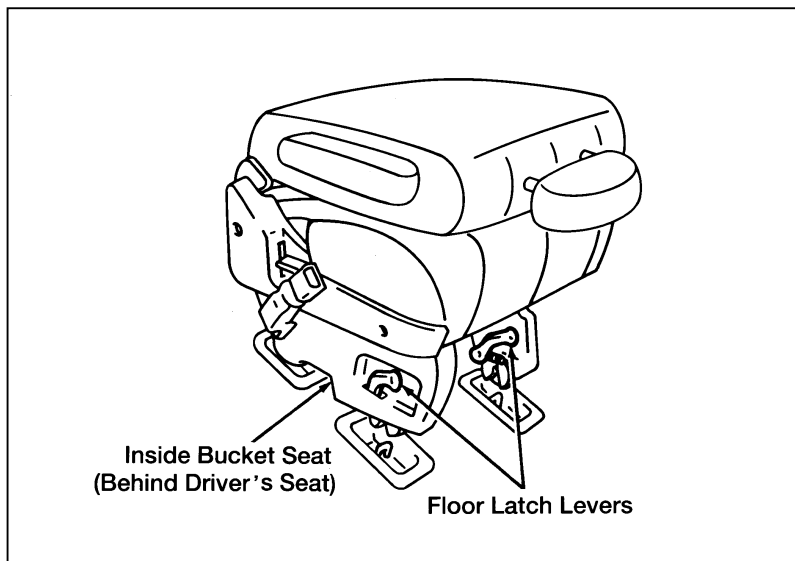

The removable inside bucket seat

3. Place your hand under the seat cushion and tip the front of the seat upward slightly. Slide the seat rearward to release the seat from its anchor position.
4. Two people should lift the seat and remove it from the vehicle.
5. Replace any floor mats that were removed.

NOTE: The bucket seats are not interchangeable due to the locations of the floor latch levers. Each seat must be reinstalled in its original position. In addition, the seat behind the driver seat only has one arm rest.

Installing the Removable Bucket Seats

To position the bucket seats back in their original positions:

1. Make sure the area around the floor anchor positions is free from obstruction.
2. With the seatback folded down, two people should lift the seat into the vehicle.
3. Place the seat slightly behind the floor anchor positions and catch the rear leg anchors into each anchor position.
4. Press down on the front of the seat to secure the front legs to the two floor latch locks. Place the seatback in the upright position.
5. Try to move the seat to be sure that it is securely fastened.
6. Replace any floor mats that were removed.

Labels have been provided on the side of the seats to remind you of important safety precautions.

 WARNING
--

Keep foreign objects out of the floor anchors. Objects in the floor anchors could prevent front and rear seat legs from engaging properly.

Adjustable Rear Seating

⚠ WARNING

Before sitting in the removable seats, make sure that the seat legs are securely attached by the floor anchors.
--

⚠ WARNING

Never adjust the driver's seat or seatback when the vehicle is moving.

Three-Passenger Bench Seat

When entering and exiting the vehicle, third-row passengers must be careful that they step over the auxiliary safety restraint system that is present with the second-row bench seat. Labels are provided on the back of the second-row bench seat to remind passengers to use care when exiting.

The three-passenger bench seat can be positioned in any of five positions along the seat track. Three of these positions are for seating and two are storage positions to accommodate varying cargo requirements.

Arranging the Seats for Maximum Cargo Space or Passenger Seating Flexibility

NOTE: When moving the three-passenger bench seat, the seat cushion cannot be lowered unless the seat is in a seating position. If you cannot get the seat cushion to lower, you may have the seat in a storage position.

NOTE: Before re-positioning seats, remove any floor mats that may be in the way.

Some of the different ways that your vehicle's seats can be arranged are shown below.

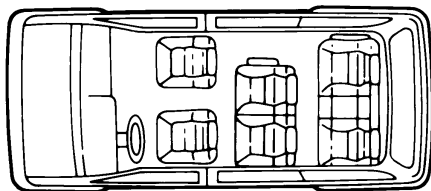

Seven-Passenger Seating

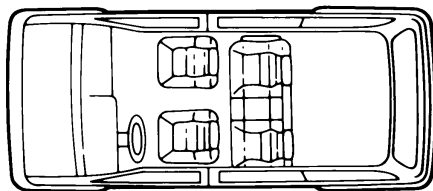

Three-Passenger Bench Seat in 2nd Row Position

NOTE: Do not try to remove the three-passenger sliding seat. Removal of the third seat may negatively affect its ability to slide properly.

Adjustable Rear Seating

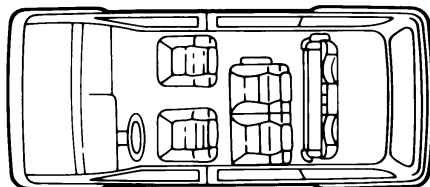

Third Seat Folded and Slid Forward

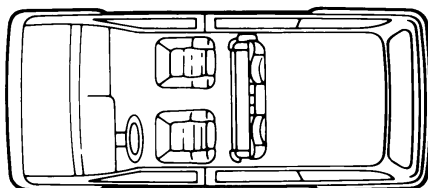

Three-Passenger Bench Seat Folded Up in Storage Position

With the second row seat(s) removed, the three-passenger bench seat can be moved all the way forward, just behind the front seats for more room in the cargo area.

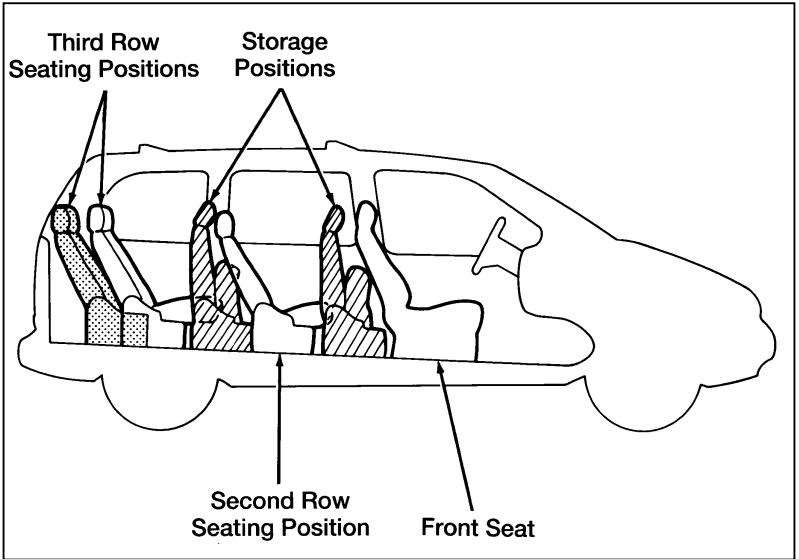

Adjustable Rear Seating

Moving the Three-Passenger Bench Seat

NOTE: When moving the three-passenger bench seat, the seat cushion cannot be lowered unless the seat is in a seating position. If you cannot get the seat cushion to lower, you may have the seat in a storage position.

The three-passenger bench seat is not removable, but it can be moved to the second-row position when the second-row bucket seats or second-row bench seat has been removed from the vehicle.

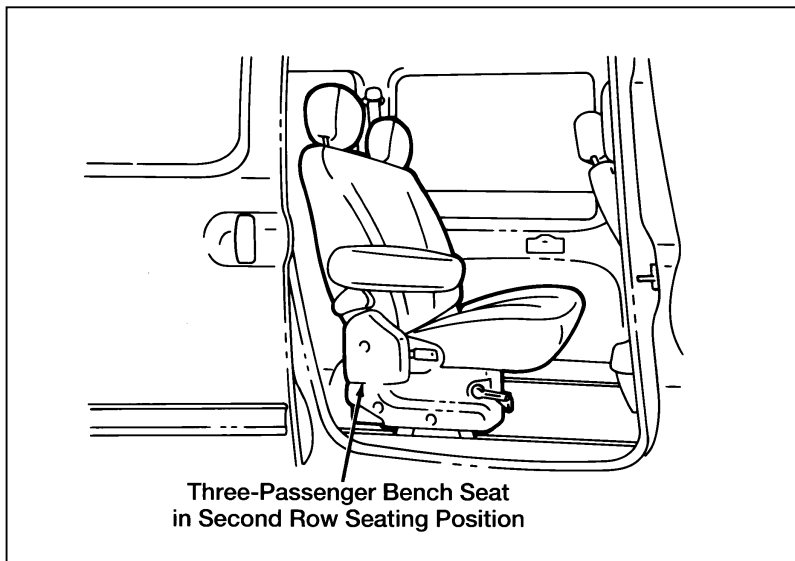

The three-passenger bench seat slid forward

⚠ WARNING

After moving the third-row seat, be sure to latch the seat in a passenger seating position. Improper location of the seat will prevent correct use of the safety belts and will increase the risk of severe injury in an accident. After sliding the seat, check that both sides of the seat are locked securely by attempting to move each side of the seat forward and backward. This must be done before the vehicle is put into motion in order to prevent unintended movement of the seat and potential passenger injuries.

NOTE: Before rearranging the seats, remove any floor mats that might be in the way.

The three-passenger seat can be stored behind the second-row seat(s) to provide extra cargo space in the rear of the vehicle.

With the second row seat(s) removed, the three-passenger bench seat can be moved all the way forward, just behind the front seats for more room in the cargo area.

Adjustable Rear Seating

To move the seat all the way forward:

1. Lift up on the seat cushion release lever and fold up the seat cushion.

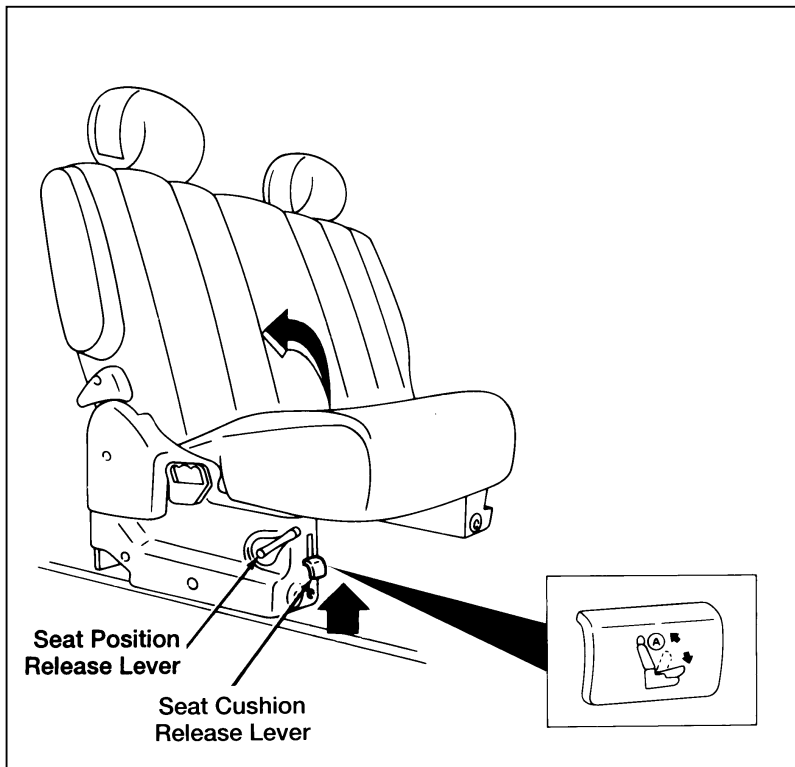

Seat cushion release lever location

A label describing seat operation can be found underneath the seat cushion.

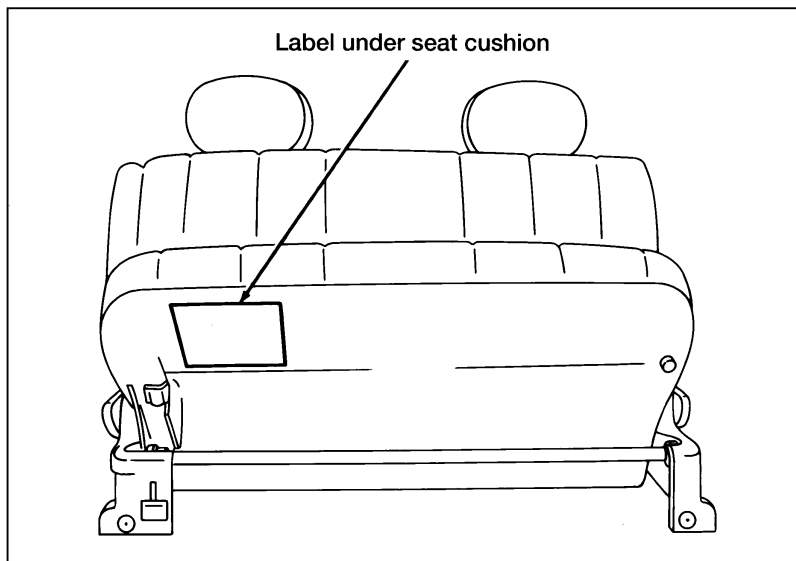

Seat cushion label location

2. Lift up on the seat position release lever and hold while sliding the seat along the seat tracks in the floor of the vehicle.

Adjustable Rear Seating

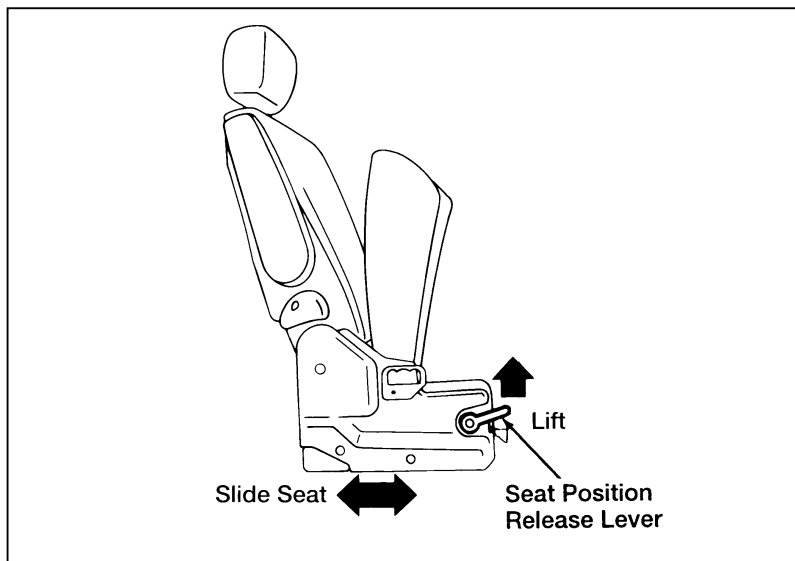

Sliding the three-passenger seat

NOTE: When sliding the seat, be sure the middle belt tongue and buckle are fastened. This will prevent the belt from falling to the floor or becoming caught between the seat cushion and the seatback. Keep the middle seatbelt tongue and buckle fastened when not in use.

3. Make sure the seat securely latches in the lock position of both seat tracks before driving with the rear seat in this position.

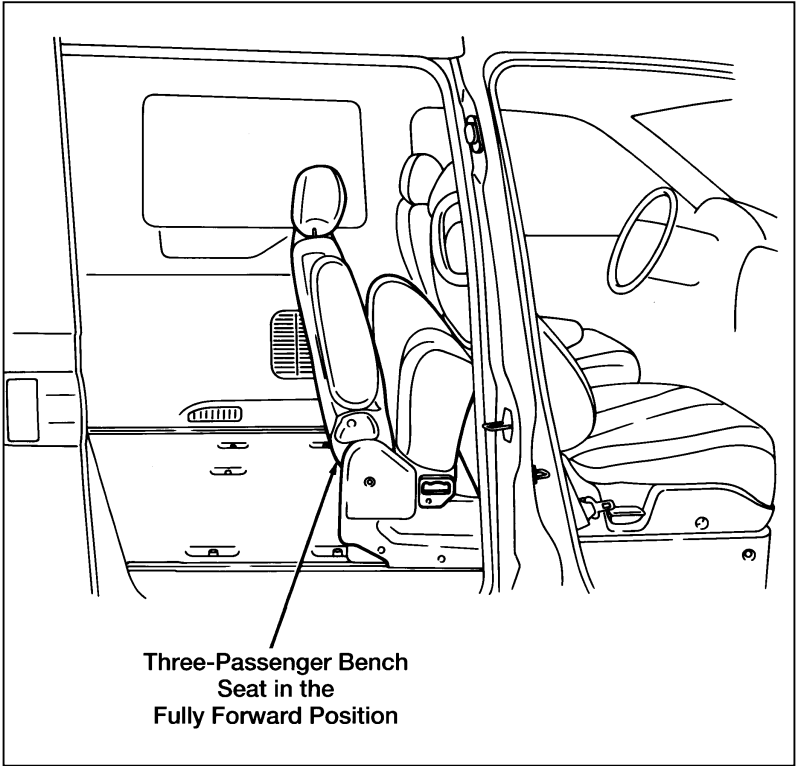

**Three-Passenger Bench
Seat in the
Fully Forward Position**

The three-passenger seat in the fully forward locked position

Adjustable Rear Seating

4. Lower the seat cushion only if in a seating position. The seat cushion will not lower in a storage position. Do not try to lower the seat cushion by force because doing so could damage the seat.
5. Replace any floor mats that were removed.

 WARNING
--

<p>Every time you adjust any seat, check to be sure that it is properly latched in the lock position of both seat tracks. If the seat is not properly latched, it could come loose and increase the risk of severe injury or death in an accident.</p>

Fold-Down Table-Top Seats (If equipped)

The second and third row seats convert to table tops with built-in cupholders. Lift up on the seatback release lever and fold seatback forward.

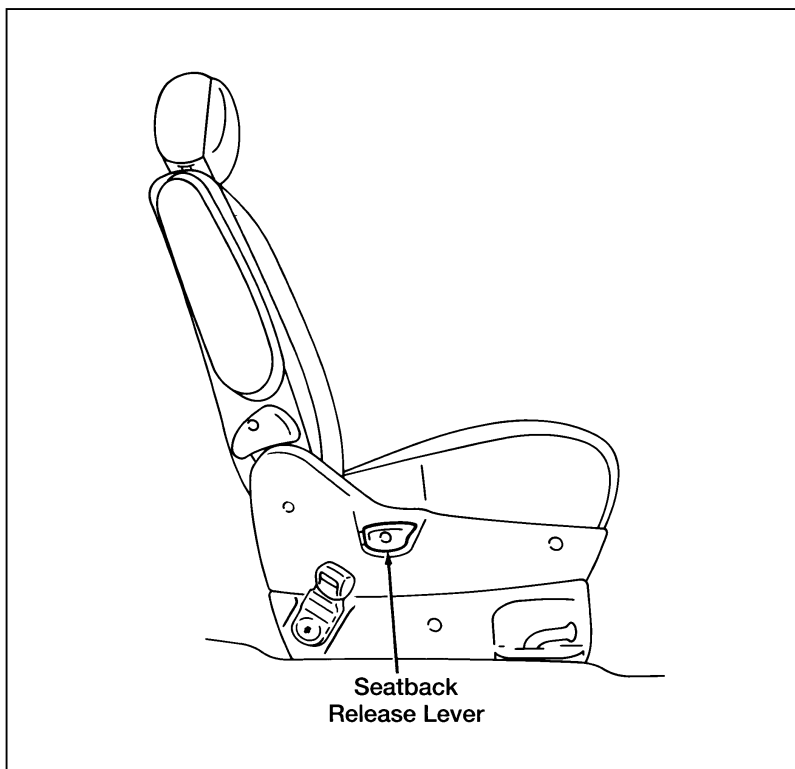

Seatback release lever location

Adjustable Rear Seating

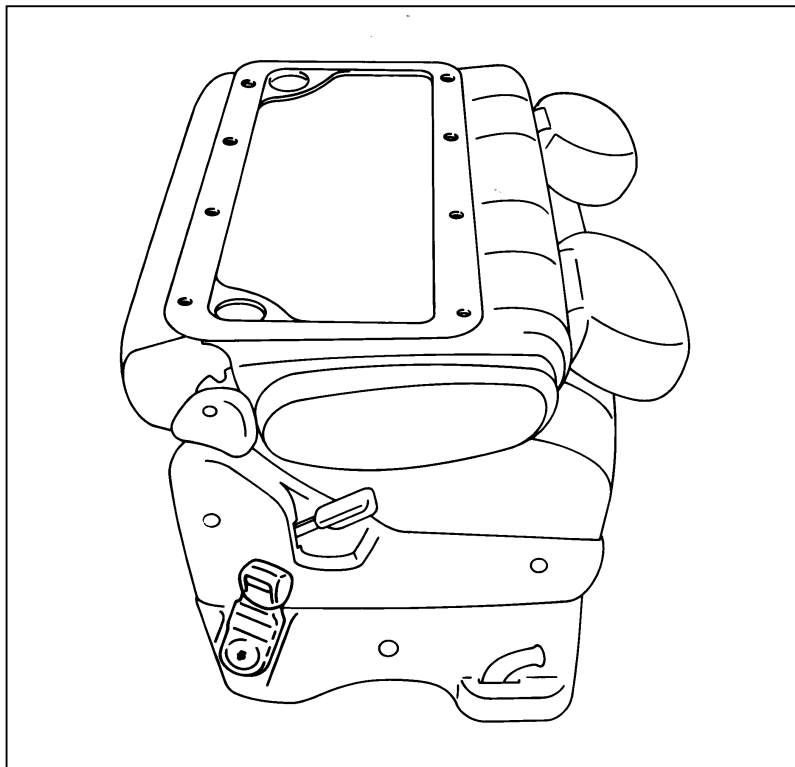

Table and built-in cupholders on the fold-down seatback

WARNING

You should never place hard items such as coffee mugs or drinking glasses on the table-top seats when the vehicle is moving. Any item can become a projectile inside a vehicle involved in a collision. To help prevent personal injury, never leave loose items on the fold-down table-top seats when the vehicle is moving.

Electronic Sound Systems

Audio Systems

Your vehicle has one of four audio systems depending upon which options you selected.

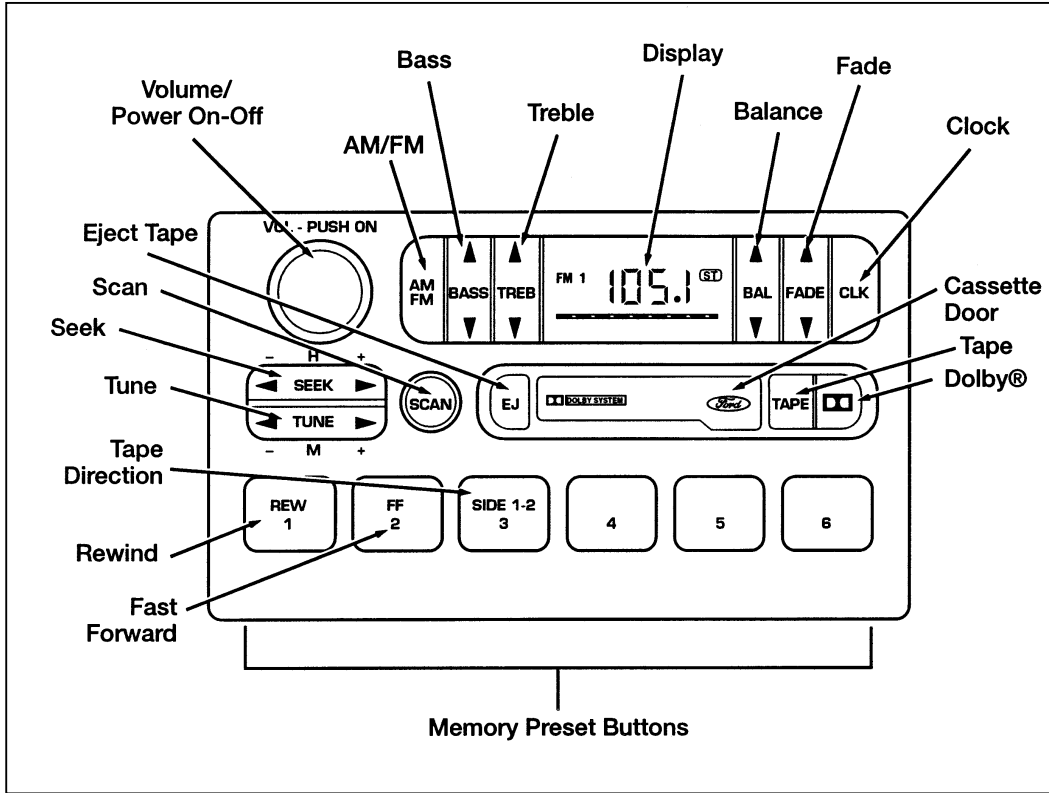

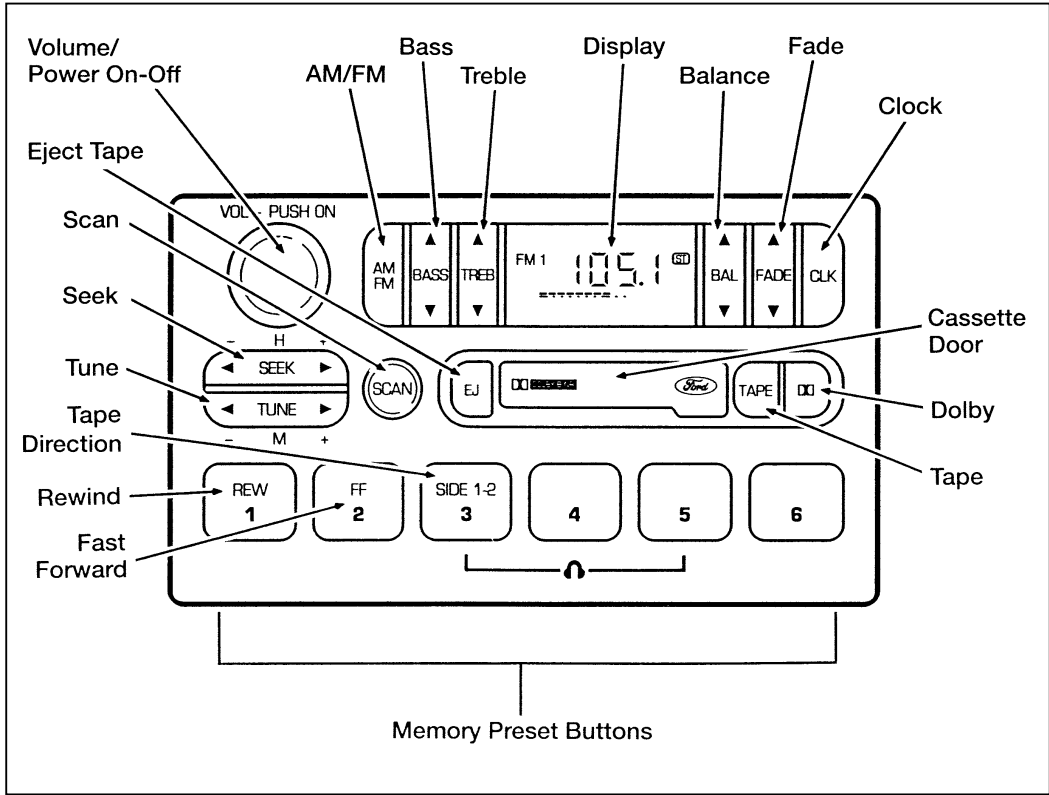

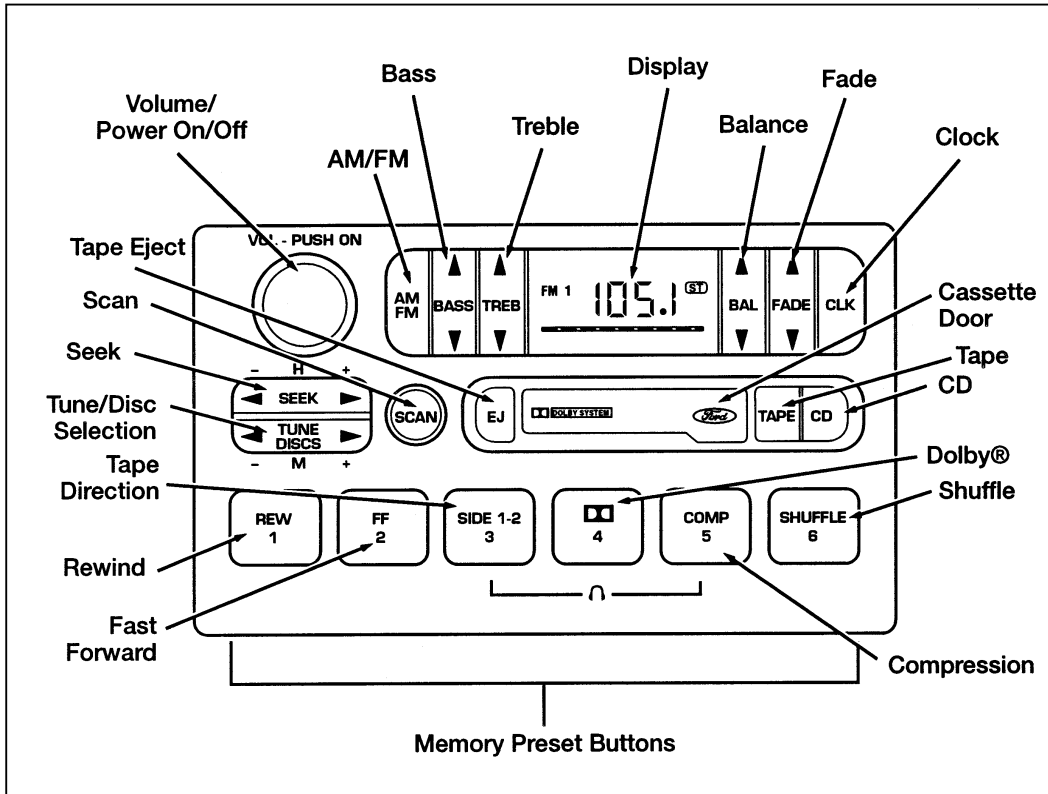

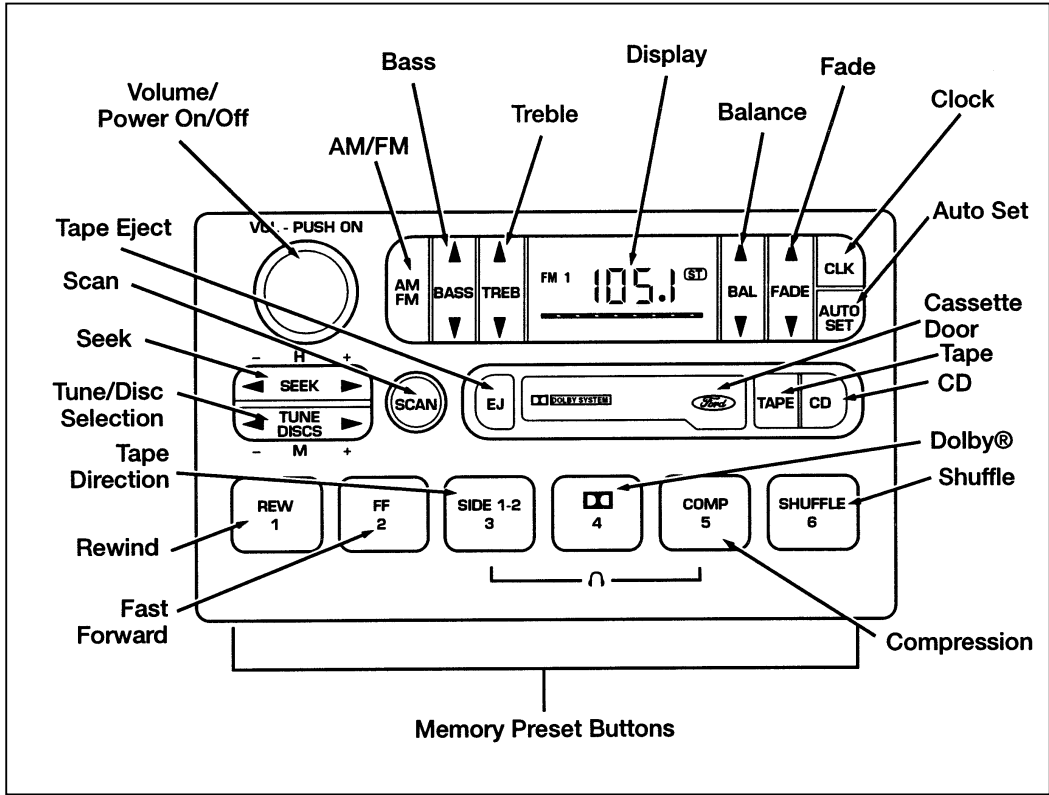

Radio Controls

NOTE: The antenna will be in the up position when the radio is playing and in the down position when the radio is off or if a cassette or CD (if equipped with CD changer) is playing.

How to turn the radio on and off

Press the VOL-PUSH ON knob or the “AM/FM” button to turn on the radio. Press the “VOL-PUSH ON” knob again to turn it off.

How to adjust the volume

Turn the “VOL-PUSH ON” knob to increase/decrease volume. Bars illuminate in the display to show the relative volume level.

NOTE: If the volume level is set above a certain listening level when the ignition switch is turned off, when the ignition switch is turned back on, the volume will come back to a “nominal” listening level. However, if the radio power is turned off, the volume will remain in the position it was set at when radio power is switched back on.

Selecting the AM or FM frequency band

Push the “AM/FM” button to select the desired frequency band. When in the radio mode, pushing the button more than once will alternate between AM, FM1 and FM2. These functions are used with the station memory buttons described under **How to tune radio stations**.

How to tune radio stations

There are four ways for you to tune in to a particular station on the radio. You can manually locate the station by using the “TUNE” function, “SEEK” to the station, “SCAN” to the station or select the station by using the memory buttons, which you can set to any desired frequency.

Electronic Sound Systems

- Using the “TUNE” button to select the tune function

You can change the frequency up or down one increment at a time (FM changes in increments of 200 kHz; AM changes in increments of 10 kHz) by pressing the “TUNE” button. To change frequencies quickly, press and **hold down** either the right or left side of the “TUNE” button.

Manual tuning adjusts your radio to any allowable broadcast frequency, whether or not a station is present on that frequency. (See **All About Radio Frequencies** later in this chapter.)

- Using the “SEEK” function

This feature on your radio allows you to automatically select listenable stations up or down the frequency band. Press the right (▶) side of the “SEEK” button to select the next listenable station up the frequency band. Press the left (◀) side of the button to select the next listenable station down the frequency band. By holding the button down, listenable stations can be passed over to reach the desired station.

- Using the “SCAN” button to scan radio stations

Pressing the “SCAN” button once enters the scan mode by stopping on each listenable station for a five-second sampling. The radio band (AM/FM1/FM2) will blink to indicate that the radio is scanning.

To stop the scan mode on the presently sampled station press the “SCAN” button again.

Setting the station memory preset buttons

Your radio is equipped with 6 station memory buttons. These buttons can be used to select up to 6 preset AM stations and 12 FM stations (6 in FM1 and 6 in FM2). Follow the easy steps below to set these buttons to the desired frequencies:

1. Select a band, then select a frequency.

-
2. Press one of the memory preset buttons and hold the button until the sound returns. That station is now held in memory on that button.
 3. Follow the two steps above for each station memory preset button you want to set.

NOTE: If the vehicle's battery is disconnected, the Station Memory Preset buttons will need to be reset.

- Using the Automatic Memory Store feature (Supersound only)

Activate Auto Memory Store by pushing the "AUTO SET" button once. Your radio will set the first six strong stations of the band you are in (AM, FM1 or FM2) into the memory buttons. The display will show "AUTO," then run through the frequencies, stopping momentarily on the stations being set into the memory buttons. The radio is now in the "AUTO" mode and this display will show "AUTO" each time a preset selected by "AUTO SET" is activated.

With Auto Memory Store, you can continually set strong stations into your memory buttons without losing your existing memory presets, which is especially handy while traveling. Your radio will automatically set your memory buttons to the strong local stations so you don't have to continually manually tune to existing stations.

NOTE: If there are fewer than six strong stations in the frequency band, the remaining unfilled buttons will store the last strong station detected on the band.

After all stations have been filled, the radio will begin playing the station stored on memory button 1.

To deactivate the Auto Memory Store mode and return to the manually-set memory button stations, simply push the "AUTO SET" button. Display will show "AUTO" then "OFF."

Electronic Sound Systems

Using the “BASS” and “TREB” buttons to adjust the tone balance and speaker output

Push the top of the “BASS” button to increase the bass response and push the bottom of the “BASS” button to decrease the bass response. The display will show “BASS” and the volume indicators will show the bass level.

Push the top of the “TREB” button to increase the treble response and push the bottom of the “TREB” button to decrease the treble response.

Adjusting Speakers

Adjusting speaker balance

Balance control allows you to adjust the sound distribution between the right and left speakers. Push the top of the “BAL” button to shift the sound to the right speakers, and push the bottom of the “BAL” button to shift the sound to the left speakers.

Adjusting speaker fader

Fade control allows you to adjust the sound distribution between the front and rear speakers. Push the top of the “FADE” button to shift the sound to the front speakers, and push the bottom of the “FADE” button to shift the sound to the rear speakers.

NOTE: Illuminated bars in the display show relative levels of bass and treble, and positions of speaker balance and fader functions (left to right, front to rear).

Cassette Tape Player Controls

How to insert a tape

Your cassette tape player is equipped with power loading. Once you insert a tape and push slightly (with the **open edge to the right**), the loading mechanism draws the tape the rest of the way in and play will begin after a momentary tape tightening process.

NOTE: A cassette tape can be loaded with the ignition on whether or not the radio power is on. Inserting a cassette tape with the radio power off will turn the audio system on. After the cassette is ejected, the audio system will turn off. Also, the antenna will be in the down position whenever the radio is not playing (i.e., when a cassette or compact disc is playing or when the radio power is off).

How to locate a desired selection on the tape

There are four ways to locate a desired selection on the tape. You can use the fast forward, rewind, "SEEK" or "SCAN" function. Following are brief descriptions of each.

1. Fast forwarding the tape

To fast forward the tape, press the "FF" button. The "■" display blinks while the tape fast forwards. The radio will automatically begin playing until fast forward is manually stopped (by pressing "FF" button) or the end of the tape is reached. (At the end of the tape, the direction automatically reverses and plays the other side of the tape.)

Electronic Sound Systems

2. Rewinding the tape

To rewind the tape, press the “REW” button. The “■” display blinks while the tape rewinds. The radio will automatically begin playing until rewind is manually stopped (by pushing the “REW” button) or the beginning of the tape is reached.

3. Using the “SEEK” function with a cassette tape

While in the tape mode, push the right (▶) side of the “SEEK” button to seek forward to the next selection on the tape. Push the left (◀) side of the “SEEK” button to seek the previous tape selection. The “TAPE” display blinks.

NOTE: If you want to restart a currently playing tape selection, press the left (◀) side of the “SEEK” button after three seconds into the current selection.

4. Using the “SCAN” button to scan cassette selections

Press the “SCAN” button to enter the scan mode (display blinks “SC”) to begin the forward scan mode on the tape currently playing, stopping on each tape selection for a five-second sampling.

The scan mode continues to the other side of the tape after one side of the tape has been played completely.

To stop the scan mode on the presently sampled tape selection, press the “SCAN” button again, or press “TAPE,” “CD” (if equipped), “TUNE,” or “SEEK.”

Reversing the direction

The alternate track of the tape can be selected anytime by pressing the “SIDE 1-2” button.

How to eject the tape

To stop the tape and eject the cassette, press the “EJ” button. The radio will resume playing if the radio power is on. The tape cartridge can be ejected with radio power (and/or ignition) on or off.



How to store the tape

Press the “AM/FM” button to stop the tape player and resume radio play. Similarly, press the “CD” button to stop the tape player and resume CD play. Also, pressing the “TAPE” button while the tape is playing pauses tape play.

The “■” symbol displays to indicate there is a tape in the player. The symbol will be lit until you push the “TAPE” button to resume tape play.

Using the Dolby B noise reduction feature

NOTE: Noise reduction system manufactured under license from Dolby Labs Licensing Corporation. “Dolby” and double-D symbol are trademarks of Dolby Laboratories Licensing Corporation.

Push the  button to activate Dolby B noise reduction. When on, the  symbol will appear in the display.

Tips on caring for your cassette player and tapes

In order to keep your cassette tape player performing the way it was meant to, read and follow these simple precautions:

- Only cassettes that are 90 minutes long or less should be used. Tapes longer than 90 minutes are thinner and subject to breakage or may jam the tape player mechanism.
- Protect cassettes from exposure to direct sunlight, high humidity and extreme heat or cold. If they are exposed to extreme conditions, allow them to reach a moderate temperature before playing.

Electronic Sound Systems

- Loose labels on cassette tapes can become lodged in the mechanism. Remove any loose label material before inserting a cassette.
- If a tape is loose inside the cassette, tighten it before playing by putting your finger or a pencil into one of the holes and turning the hub until the tape is tight.
- Using a Ford Cassette Cleaning Cartridge to clean the tape player head after 10-12 hours of play will help maintain the best playback sound and proper tape operation.

Clock Operation

How to View the Clock Mode

Press the “CL” button to alternate the frequency/tape/CD (if equipped) and time in the display. In the clock mode, pressing any radio/tape/CD (if equipped) function will automatically display the radio frequency/tape/CD (if equipped) for approximately ten seconds before changing back to the clock mode.

How to Set the Clock

1. Turn the ignition on (clock can be set when radio is on or off).
2. Press and hold in the “CLK” button, press the “SEEK” button left (◀) to advance the hours and right (▶) to advance the minutes.

NOTE: The clock displays 12-hour time with no A.M./P.M. indications.

Ford CD Changer (If equipped)

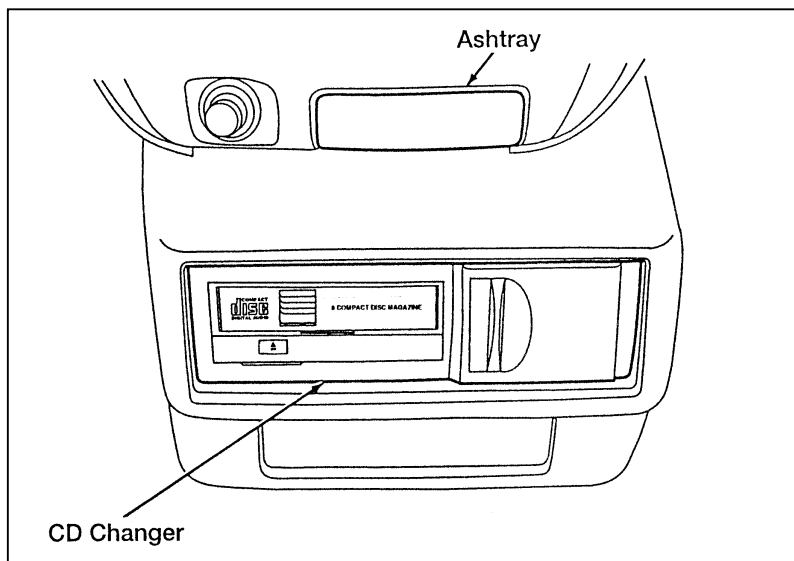

Ford CD Player

The Ford Compact Disc Changer operates when the CD compatible or Supersound Audio System is on and a magazine with disc(s) is inserted. Handle the discs by their edges only. Be sure to read and follow all of the care and cleaning instructions under *How to Take Care of and Clean Your CD Changer and Discs*.

NOTE: A CD magazine can be loaded with the ignition on whether or not the radio power is on. Inserting a CD magazine with the radio power off will turn the audio system on. After the CD magazine is ejected, the audio system will turn off. Also, the antenna will be in the down position whenever the radio is not playing (i.e., when a cassette or compact disc is playing or when the radio power is off).

Electronic Sound Systems

NOTE: In some instances, the radio may have CD changer controls, even if there is no CD changer.

The digital display on the radio shows the disc and track number. Indicators for compression (“COMP”) and shuffle on (“SHUFFLE”) are also in the display. These features are described in more detail later in this chapter.

Once a magazine is inserted, operation of the CD changer will override that of the cassette player or radio.

NOTE: The volume, bass, treble, balance, and fader controls on the radio are also used with the CD changer.

Slide the CD door all the way to the right. Insert the magazine into the magazine opening. If a magazine is already loaded, pressing “CD” will start CD play. For the first three seconds after a disc starts playing, the radio display shows the disc number (CD-01 for disc 1). From seconds four through six, the track number is shown (TR-02 for track 2). For the remainder of the track, the display shows the disc and track number (01-02 for disc 1, track 2).

When the disc reaches the end, the disc changer automatically goes to the beginning of the next disc and resumes playing.

How to eject the CD magazine

Press the eject button on the lower left of the CD changer to eject the magazine whether or not the audio system is on.

NOTE: If the ignition key is turned OFF during play and then is set to the ON or ACCESSORY position, the CD changer will resume playing in the mode (radio/tape/CD) it was in when ignition was turned off.

How to locate a selection on your CD Changer using Automatic Music Search

Automatic Music Search allows you to quickly find a particular selection on the selected disc. Press the left (◀) side of the “SEEK” button to locate a previous track or the right (▶) side of the “SEEK” button to locate a later selection.

How to fast forward or rewind your CD Changer

To quickly search for a particular point in a selection, press and hold the “REW” button. Holding this button for more than three seconds causes the CD mechanism to reverse at a faster speed. The audio level will drop and the elapsed time will be displayed during the fast reverse period.

Pressing the “FF” button functions the same as the “REW” button except in the opposite direction.

How to switch discs

To switch discs while in the CD mode, press the “TUNE DISCS” button. Press the left (◀) side to play the previous disc. Press the right (▶) to play the next disc.

When you have reached the end of the disc by keeping the fast forward (“FF”) button pressed, the display will show the end time of the last track and the sound will be muted. When the fast forward (“FF”) button is released, the player resumes play at the beginning of the first track.

Using the “SCAN” function

Press the “SCAN” button to enter the scan mode. The CD changer will begin scanning the disc, stopping on each listenable track for approximately a ten-second sampling. This continues until you press the “SCAN” button a second time or eject the disc. While in the scan mode, the track number flashes in the display.

Electronic Sound Systems

Special Features of Your CD Player

Compression

The compression feature will bring soft and loud passages closer together for a more consistent listening level.

To turn the compression on, press the “COMP” button. When on, the compression indicator (“C”) will appear in the display. Press the button again to turn off.

Shuffle

Press the “SHUFFLE” button to turn on. Press it again to turn off. When the shuffle mode is activated, the display will show “SHF” for two seconds. When a new track is selected by the shuffle feature, “SHF” will again be displayed for two seconds.

Shuffle and Scan

Both the shuffle and scan features can be activated simultaneously. In this mode, the player will randomly pick a selection and play the first ten seconds. This process is continued until either the “SCAN” button or “SHUFFLE” button is pressed a second time.

How to Eject the Disc

Push the eject button on the lower left corner of your CD changer to stop play, eject the magazine and resume radio or tape operation of your audio system.

How to Take Care of and Clean Your CD Changer and Discs

To ensure the continued performance of your Ford Compact Disc Changer, carefully read the following precautions:

- Always handle the disc by its edge. Never touch the playing surface.
- Before playing, inspect the disc for any contamination. If needed, clean the disc with an approved disc cleaner, such as the Discwasher® Compact Disc Cleaner or the Allsop 3® Compact Disc Cleaner, by wiping from the center out to the edges. **Do not use a circular motion to clean.**
- Do not clean discs with solvents such as benzine, thinner, commercially available cleaners or antistatic spray intended for analog records.
- Do not expose the disc to direct sunlight or heat sources such as defroster and floor heating ducts. Do not leave any discs in a parked car in direct sunlight where there may be a considerable rise in temperature or damage may result.
- After playing, store the disc in its case.
- If a disc has already been inserted, do not try to insert another disc. Doing so may damage the disc changer.
- Do not insert anything other than a disc into the disc changer.

 WARNING
The laser beam used in the compact disc player is harmful to the eyes. Do not attempt to disassemble the case.

Electronic Sound Systems

Common Operating Conditions of Your CD Changer

The following information is designed to help you recognize typical situations that could be mistakenly interpreted as mechanical malfunctions of the disc player.

- A disc is already loaded.
- The disc is inserted with the label surface downward.
- The disc is dusty or defective.
- The player's internal temperature is above 167°F (75°C). Allow the player to cool off before operating.
- Different manufacturers of compact discs may produce discs with different dimensions or tolerances, some of which may not be within industry standards or in accordance with the CD format. Because of this, a new disc that is free of dust and scratches could be defective and may not play on your Ford Compact Disc Changer.

If play does not begin after the CD button is pushed:

- Moisture may have condensed on the lenses within the unit. If this occurs, remove the disc and wait approximately an hour until the moisture evaporates.

If the sound skips:

- Badly scratched discs or extremely rough roads will cause the sound to skip. Skipping will not damage the disc player or scratch the discs.

Rear Seat Radio Control Operation

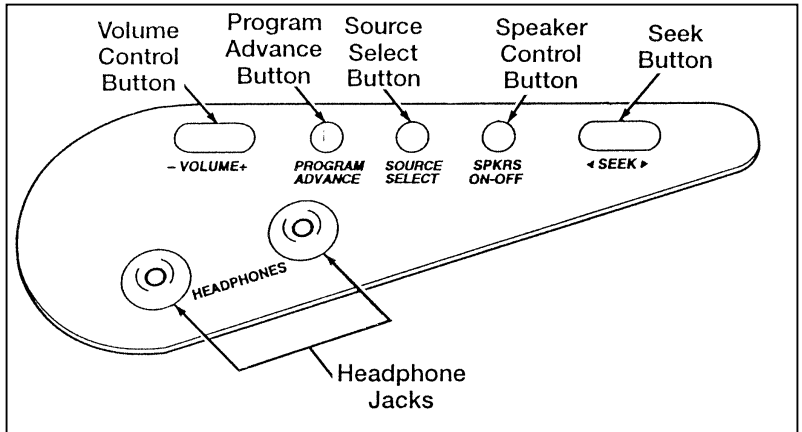

Rear seat radio controls

How to turn the rear seat radio controls on and off

Press memory preset buttons “3” and “5” simultaneously on the face of your radio to turn the rear seat radio controls on. A headphones symbol (🎧) will appear in the display when the rear seat controls are on. Press “3” and “5” simultaneously again to turn rear seat radio controls off.

How to adjust the volume

Press the right (+) side of the “VOLUME” rocker switch to increase volume, and push the left (-) side to decrease the volume of the rear speakers.

NOTE: Rear seat control volume can be set no higher than current radio setting.

Electronic Sound Systems

Using the “PROGRAM ADVANCE” button

This button has different functions depending on the audio source. In radio mode, pressing this button will cycle through the memory presets for the given frequency band (AM, FM1, FM2). In the cassette mode, pressing this button will change tape sides. During the CD operation, this button will cycle through the discs (one button push, one disc advance).

Using the “SOURCE SELECT” button

This button will cycle through all modes then begin to play. The cycle order is as follows: AM, FM1, FM2, tape, CD (if equipped).

How to turn the speakers on and off

When the rear seat controls are on, push the “SPKRS, ON-OFF” button to turn all speakers off. Push again to turn all speakers on.

Using headphones with the rear seat controls

Two 3.5mm headphone jacks have been provided on the rear seat controls. Plug headphones into the provided jack(s) to operate headphones. Note that the headphones can be used only when the speakers are off.

Using the “SEEK” button

This button has different functions for each source (mode). In radio mode, pressing “SEEK” proceeds to the previous or next station. In cassette mode, this button is an Automatic Music Search (AMS), moving to the next or previous selection on the tape. In CD mode, this button moves to the beginning of the next or previous track.

How to Use Your Steering Wheel Audio Controls (If equipped)

If your vehicle is equipped with steering wheel audio controls, the controls are located on the inner right rim of the steering wheel. These controls duplicate some of the audio functions.

How to adjust volume

Press the up arrow button (▲) to increase the volume.

Press the down arrow button (▼) to decrease the volume.

Using the “NEXT” button

This control has different functions for each source (mode). In the radio mode, the radio will cycle through the memory presets for the given frequency band. In cassette mode, the tape advances to the next selection. In CD mode, the CD will move to the next track on the given disc.

Common Radio Reception Conditions

Several conditions affect FM reception and can result in noise or interference in the reception. These are:

Distance/Strength

The strength of the FM signal is directly related to the distance the signal must travel. The listenable range of an average FM signal is approximately 25 miles (40 km). Beyond this distance, the radio is operating in a “fringe” area and the signal becomes weaker.

Terrain

The terrain (hills, mountains, tall buildings) of the area over which the signal travels may prevent the FM signal from being noise-free.

Electronic Sound Systems

If there is a building or large structure between the antenna and station, some of the signal “bends” around the building, but certain spots receive almost no signal. Moving out of the “shadow” of the structure will allow the station to return to normal.

This condition exists when the radio waves are reflected off objects or structures; the reflected signal cancels the normal signal, causing the antenna to pick up noise and distortion. Cancellation effects are most prominent in metropolitan areas, but also can become quite severe in hilly terrain and depressed roadways.

To minimize the effects of these conditions, a stereo/mono blend circuit has been incorporated into this system. This feature automatically switches a weak stereo signal to a clearer monaural signal, which improves the quality of reception.

Several sources of static are normal conditions on AM frequencies. These can be caused by power lines, electric fences, traffic lights and thunderstorms.

Another reception phenomenon is **Strong Signal Capture and Overload**. This can occur when listening to a weak station and when passing another broadcast tower. The close station may capture the more distant station, although the displayed frequency does not change. While passing the tower, the station may switch back and forth a few times before returning to the original station.

When several broadcast towers are present (common in metropolitan areas) several stations may overload the receiver, resulting in considerable station changing, mixing and distortion.

Automatic gain control circuitry for both AM and FM bands has been incorporated into this system to reduce strong signal capture and overload.

All About Radio Frequencies

The Federal Communications Commission (FCC) and the Canadian Radio and Telecommunications Commission (CRTC) establish the frequencies that AM and FM radio stations may use for their broadcasts. The allowable frequencies are: AM: 530, 540...1700, 1710 kHz in 10 kHz steps; FM: 87.9, 88.1...107.7, 107.9 MHz in 0.2 MHz steps.

Not all frequencies will be assigned to a given area. This radio will tune to each of these frequencies using manual tuning and no fine tuning is necessary as radio stations may not use other frequencies.

Some FM radio stations advertise a “rounded-off” frequency which is not the frequency on which they actually broadcast. For example, a radio station that is assigned a frequency of 98.7 MHz may call itself “Radio 99” even though 99.0 MHz is not an allowable FM broadcast frequency.

Important Warranty and Service Information

About Your Warranty

Your sound system is warranted for three years. Consult your vehicle warranty booklet for further information.

Servicing Your Audio System

At Ford Audio, we stand behind our audio systems with a comprehensive service and repair program. If anything should go wrong with your Ford Audio System, return to your dealer for service. There is a nationwide network of qualified Ford authorized repair centers to service your problem.

Driving Your Villager

Automatic Transaxle Operation

Putting Your Vehicle in Gear

Your vehicle's gearshift lever is on the steering column. The OVERDRIVE OFF/ON button is located on the end of the gearshift lever. You can put the gearshift lever in any one of several positions.

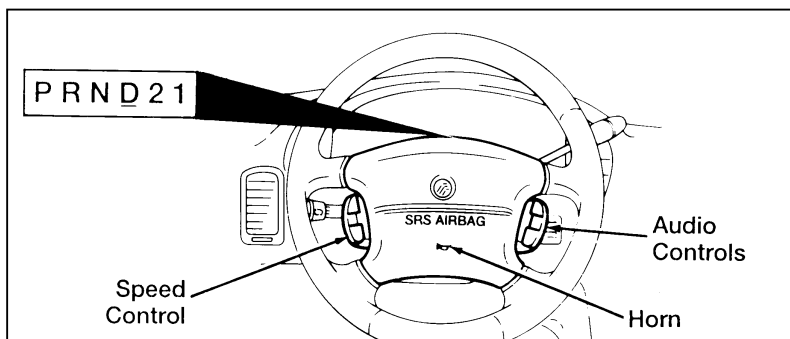

The steering column gearshift lever positions

⚠ WARNING

Hold the brake pedal down while you move the gearshift lever from position to position. If you do not hold the brake pedal down, your vehicle may move unexpectedly and injure someone.

Once you place the gearshift lever securely into position, gradually release the brake pedal and use the accelerator as necessary.

Shift-lock Safety Feature

Your vehicle has a special shift-lock safety feature which prevents you from shifting out of P (Park) without the brake pedal depressed. To shift the transaxle out of the P (Park) position, the ignition must be in the ON position and your foot must be pressing on the brake pedal.

If the shift lever cannot be moved from the P (Park) position with the brake pedal depressed:

1. Shut the engine off and remove the ignition key.
2. Apply the parking brake.
3. Reinsert the ignition key and turn it clockwise to the first position (OFF).
4. Depress the brake pedal, move the gearshift lever to N (Neutral) and start the engine.

If you need to shift out of P (Park) by using the alternate procedure described above, it is possible that a fuse has blown and that your brakelamps may also not be functional. Please refer to the chapter titled *Servicing Your Villager* in this Owner Guide for instructions on checking and replacing fuses.

 WARNING
--

DO NOT DRIVE YOUR VEHICLE UNTIL YOU VERIFY THAT THE BRAKELAMPS ARE WORKING.
--

Backing Up

Before shifting into or out of R (Reverse), you should always come to a complete stop.

Driving Your Villager

Driving

When to use D (Overdrive)

Overdrive is the normal driving position. When the gearshift lever is placed in (D) Overdrive, and the Overdrive Off button has not been pressed, the vehicle will automatically upshift to second, third and fourth gears. The transaxle will shift into the correct gear when the right speed is reached.

When to use D (Drive — with the Overdrive Off button activated)

You will notice that there is only one drive position on your gearshift selection indicator (instead of Drive and Overdrive). You will find a button labeled OVERDRIVE OFF/ON located on the gearshift lever. Push in the button on the end of the lever and the O/D OFF light in the instrument cluster will illuminate. With the O/D OFF light illuminated, the transaxle will operate in first, second and third gears and will not shift into fourth gear. Operating in Drive (O/D OFF) provides more engine braking than Overdrive for descending hills, or city driving.

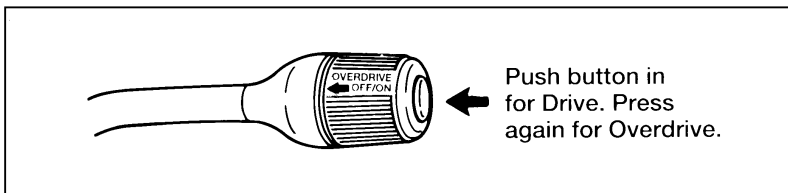

The OVERDRIVE OFF/ON button

To return the transaxle to the normal Overdrive operation, press the OVERDRIVE OFF/ON button again. Use this button to select Overdrive or Overdrive Off whenever you drive your vehicle.

NOTE: Overdrive will not engage until the engine has fully warmed up.

The transaxle will be in the “overdrive on” mode when the vehicle is started even if the O/D OFF mode was selected when the vehicle was last shut off.

If your vehicle is on an extremely slippery surface, the Electronic Transaxle Control Module may receive a signal indicating a rapid increase or decrease in wheel speed. If the module detects this condition, it will limit the transaxle operation to Third gear and Reverse. This reduces tire slippage and protects the transaxle. The transaxle will operate normally in Reverse, but will lack power during acceleration in Drive. If this happens, stop your vehicle as soon as possible and turn the ignition off for 3 seconds. Restart the vehicle. If the condition still exists, contact your dealer as soon as possible.

NOTE: If the O/D OFF indicator light is flashing on and off repeatedly when the vehicle is started, there is a transaxle electronic system malfunction. Contact your dealer as soon as possible.

When to use 2 (Second)

Use Second (2) when driving on slippery roads or to provide additional engine braking on downgrades. This position provides Second gear operation only. Do not exceed 68 mph (110 km/h) in this position.

When to use 1 (First)

Use First (1) to provide maximum engine braking on steep downgrades. Upshifts from First can be made by manually shifting to Second (2) or Overdrive (D). First (1) gear provides only first gear operation. If you select First while driving at higher speeds, the transaxle will shift to Second (2), and then shift back to First (1) after the vehicle decelerates to the proper speed. Do not exceed 35 mph (56 km/h) in this position.

Driving Your Villager

N (Neutral)

In N (Neutral), the wheels of the transaxle are not locked. Your vehicle will roll freely, even on the slightest incline, unless the parking brake or brakes are on.

Parking

Always come to a complete stop before you shift into P (Park). This position locks the transaxle and prevents the front wheels from turning. To securely latch the gearshift in the P (Park) position, pull it toward you, push it completely counterclockwise against the stop, and then push it toward the instrument panel.

The gearshift is securely latched in Park (P) if you cannot rotate it in a clockwise direction without lifting it toward you.

 WARNING
--

Always set the parking brake fully and make sure the gearshift is securely latched in P (Park).
--

 WARNING
--

Never leave your vehicle unattended while it is running.

Forced Downshifts

To gain extra acceleration in Drive (D) (when passing another vehicle) push the accelerator to the floor. The transaxle will automatically downshift to the appropriate gear - third, second or first.

Steering Your Vehicle

Your vehicle has power steering. Power steering uses energy from the engine to help steer your vehicle.

If the amount of effort needed to steer your vehicle changes at a constant vehicle speed, have the power steering system checked. If the power steering system breaks down (or if the engine is turned off), you can steer the vehicle manually but it takes more effort.

Never hold the steering wheel in the extreme right or left position for more than five seconds if the engine is running. This can damage the power steering pump.

NOTE: After any severe impact such as striking large potholes, sliding into curbs on icy roads, or a collision involving the front end, have the front suspension and steering checked for possible damage.

Brakes

When the foot (service) brake pedal is depressed, the high-mount brake lamp should illuminate.

Front Disc Brakes

The front disc brakes are self-adjusting. They do not require service other than periodic lubrication of the caliper slide rails and inspection for pad wear.

Rear Drum Brakes

The rear drum brakes are self-adjusting. Automatic adjustment occurs through normal use of the brakes.

Driving Your Villager

Four-Wheel Anti-lock Brakes

The Anti-lock Brake System (ABS) prevents wheels from completely locking up by automatically releasing and re-applying the brakes. During ABS braking, slight brake pedal pulsations may be felt on the driver's foot. These pulsations represent the rapid cycling of the ABS valves. The pedal pulsations are considered normal ABS operation, and will stop when normal braking is resumed or when the vehicle comes to a stop.

During ABS activation, a mechanical noise may be heard as the ABS system cycles. This is normal ABS operation.

The ABS system has self-check capabilities. The system turns on the ABS warning light each time you start the engine. After the engine is started and the ABS warning light turns off, the system performs another test the first time the vehicle reaches 4 mph (6 km/h). A mechanical noise may be heard as the ABS system performs a self test. This is a normal part of the self test feature. If a malfunction is found during this check, the ABS warning light will come on.

You should always be careful when braking, even if your vehicle has the ABS system. Heavy braking on roads with loose surfaces such as snow or gravel, or roads with severe pavement irregularities could also cause you to lose control of your vehicle.

 WARNING

<p>If the anti-lock brake system warning light remains on or comes on while driving, have the braking system checked by a qualified service technician as soon as possible.</p>
--

NOTE: If a fault occurs in the anti-lock system, and the brake warning light is not lit, the anti-lock system is disabled but normal brake function remains operational.

Ford Motor Company has not found any negative effects of mobile radio transmitting equipment installed on vehicles with the ABS system providing that the radio is installed according to the radio manufacturer's instructions. However, if you have had a mobile radio transmitter installed and the check ABS light comes on (at any time other than immediately after turning the key to the ON position) have your mobile radio dealer inspect the installation. Also, if the ABS system is activated other than during maximum braking, have your mobile radio installation checked.

If Brakes Do Not Grip Well or Pedal is “Low”

If the brake pedal seems “low” it may indicate the need for a brake system inspection and/or service. Apply your parking brake several times. If the condition has not improved, you should have your brakes checked as soon as possible.

Occasional brake squeal during light to moderate stops does not affect the function of the brake system and is normal. However, if the squeal becomes very loud or if it becomes more frequent, return the vehicle to your dealer for inspection.

 WARNING
Modifications to the suspension spring rates and/or vehicle ride height may adversely affect vehicle stopping ability.

Stopping Distances

Stopping distances vary with different loads and driving conditions. Use caution when you drive under new conditions and acquaint yourself with your vehicle's performance.

Driving Your Villager

Applying the Brakes

Apply the brake pedal evenly. Use the “squeeze” technique. Push on the brake pedal with a steadily increasing force. This allows the wheels to continue to roll while you are slowing down, which lets you steer properly. In the event of a sudden stop, do not pump the brakes. Pumping the brakes during an anti-lock stop will diminish braking effectiveness.

 WARNING
--

Do not drive with your foot resting on the brake pedal. This will increase your vehicle's stopping distance and may also cause brake damage.

 WARNING
--

If you are driving down a long or steep hill, shift to a lower gear. Do not apply your brakes continuously, as they may overheat and become less effective.
--

Using the Parking Brake

The parking brake pedal is suspended just below the bottom of the instrument panel to the left of the brake pedal. To set the parking brake, press the brake pedal with your right foot and hold it while you push the parking brake pedal down firmly with your left foot.

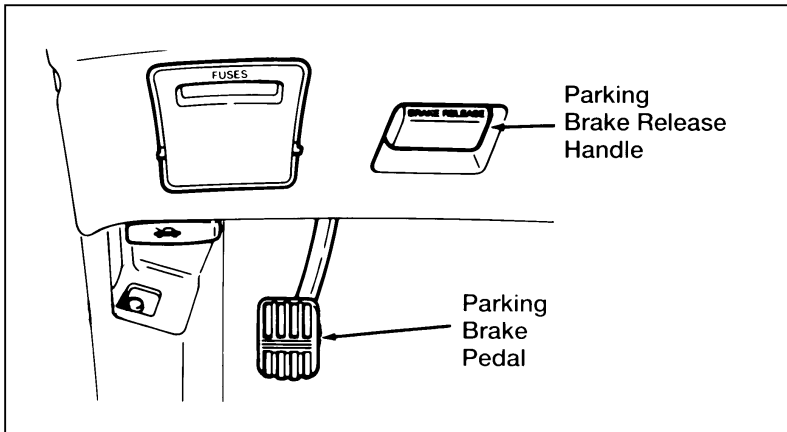

The parking brake

⚠ WARNING

When parking, do not use the gearshift in place of the parking brake. Always set the parking brake fully and make sure that the gearshift is securely latched in Park (P). Turn off the ignition whenever you leave your vehicle. Never leave your vehicle unattended while it is running. If you do not take these precautions, your vehicle may move unexpectedly and injure someone.

To release the parking brake, press the brake pedal with your right foot and hold it while you lift up on the parking brake release handle.

⚠ WARNING

If the parking brake is fully released, but the Brake System light remains on, have the brakes checked immediately. They may not be working properly.

Driving Your Villager

The parking brake is not designed to stop a moving vehicle, but you can use the parking brake to stop your vehicle in an emergency if the service brakes fail. However, since the parking brake does not stop your vehicle as quickly as the normal brakes, the stopping distance will increase greatly.

Driving Under Special Conditions

Tips for Safe Driving

As with any new vehicle, yours may drive and handle differently from your previous vehicle. Use greater care until you become accustomed to its features and driving characteristics.

Always operate your vehicle within reasonable limits. Abrupt changes in acceleration, deceleration, turning, or combinations of these maneuvers can cause a vehicle to behave differently than anticipated, especially when road conditions vary.

For example, even with anti-lock brakes, extreme braking can make it difficult to control the direction of the vehicle. Use a “squeeze” technique. Push on the brake pedal with steadily increasing force. This allows the wheels to brake, yet continue to roll so that you may steer in the direction you want to travel.

If you release the accelerator abruptly or brake hard while going too fast around a severe curve, your vehicle may change its direction of travel. Avoid applying the brakes, if possible. If you must apply the brakes, use the “squeeze” technique described earlier.

If you run off the road, do not turn the steering wheel sharply to return to the road. Instead, slow the vehicle sufficiently and gradually steer the vehicle back onto the road.

Driving at High Speeds

Ford Motor Company recommends obeying posted speed limits.

 WARNING
--

Driving too fast for conditions creates the possibility of loss of vehicle control. Driving at very high speeds for extended periods of time may result in damage to vehicle components.

 WARNING
--

Do not spin the wheels at over 35 mph (55 km/h). The tires may fail and injure a passenger or bystander.

Driving in Bad Weather

Slippery roads

Drive cautiously on wet or snowy roads.

- Do not quickly move the steering wheel unless necessary.
- Drive more slowly than you would normally.
- Give your vehicle more distance to stop.
- Use the “squeeze” technique for braking as described in previous braking sections.
- Consider using one of the lower gears.

 WARNING
--

To avoid skidding and losing control on slippery roads, do not downshift into 1 (First) when you are moving faster than 20 mph (32 km/h).
--

Driving Your Villager

 WARNING
--

The Anti-Lock Brake System may not prevent brake lock-up on extremely slippery surfaces.

High water

Do not drive through flooded areas unless you are sure that the water is below the bottom of the wheel hubs.

If you must drive through high water, drive slowly. You may have limited traction or wet brakes so allow extra stopping distance because your vehicle will not stop as quickly as usual.

After you drive through the standing water, apply your brakes gently several times as your vehicle moves slowly to help dry the brakes.

Rocking the Vehicle

If your vehicle gets stuck (for example, in mud or snow), you may rock it out. Shift in a steady rhythm between forward and reverse gears. At the same time, press lightly on the accelerator. If you are still stuck after a few minutes of rocking, call for a tow truck.

Do not rock the vehicle for more than a few minutes. This may overheat the engine, damage the transaxle, or damage the tires.

Driving With a Heavy Load

The Safety Compliance Certification Label, located on the driver's door pillar, provides important information regarding the weight limits your vehicle can safely carry or tow. The total weight of your vehicle, including the weight of the passengers and cargo, should never be more than the Gross Vehicle Weight Rating (GVWR). Also, the weight that your vehicle carries on the front axle and rear axle should never be more than the Gross Axle Weight Rating (GAWR) for the respective axle.

The load capacities of your vehicle's tires affect the GVWR or GAWR limitations. Using replacement tires with a higher weight limit than the originals does not increase GVWR or GAWR. Using lower capacity replacement tires may lower GVWR and GAWR limitations.

 **WARNING**

If the GVWR or the GAWR specified on the Safety Compliance Certification Label is exceeded, your vehicle may be damaged or you may lose control and injure someone.

Vehicle/Trailer Loads

Your vehicle may tow a Class I trailer up to 2,000 lbs. (907 kg) provided the Gross Vehicle Weight (GVW) is less than the GVWR shown on the Safety Compliance Certification Label. With the optional trailer tow package, your vehicle can tow a trailer up to 3,500 lbs. (1,588 kg).

Trailer Towing (may require trailer tow option package)

Towing a trailer puts an additional load on your vehicle's engine, transaxle, axle, brakes, tires and suspension. For your safety and for the good of your vehicle, use the right equipment for the type of trailer you tow.

- Stay within the load limits when you tow.
- Carefully and thoroughly prepare your vehicle for towing, making sure to use the right equipment and to attach it properly. See *Preparing to Tow* in this section.
- Use extra caution when driving your vehicle while you tow. See *Driving While You Tow* in this section.
- Service your vehicle more frequently if you tow a trailer. See *Servicing Your Vehicle if You Tow* in this section.

Driving Your Villager

Do not tow a trailer until your vehicle has been driven at least 500 miles (800 km).

Vehicle Loading Information

Your vehicle's load capacity is designated by weight, not volume, so you cannot necessarily use all the available space. Maximum safe vehicle weights as well as tire sizes, rim sizes and inflation pressures are specified for your vehicle at the assembly plant on the Safety Compliance Certification Label. The certification label is located on the pillar in the driver's door opening.

Each additional item of equipment affects how much cargo a vehicle can carry. If a vehicle is overloaded, performance will suffer and service concerns may arise.

The following is a typical example of a Safety Compliance Certification Label and an explanation of how this information should be used:

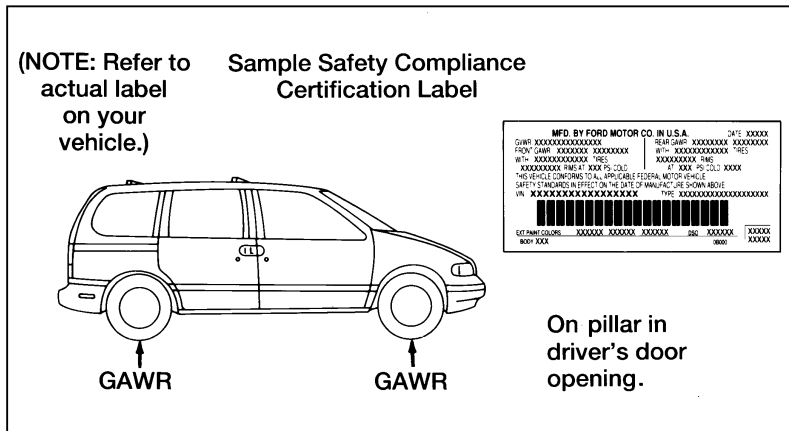

The Safety Compliance Certification Label

NOTE: The vehicle must not be loaded to both the front and rear GAWR because the GVWR will be exceeded. The GAWR of the front and rear axles exceed the GVWR when added together.

There are no numbers on the sample Safety Compliance Certification Label shown. Refer to the actual numbers on your vehicle's Safety Compliance Certification Label.

Understanding Loading Information

There are five terms that are used to describe a vehicle's ability to carry a load:

- Base Curb Weight
- Payload
- GVW (Gross Vehicle Weight)
- GVWR (Gross Vehicle Weight Rating)
- GAWR (Gross Axle Weight Rating)
- GCWR (Gross Combined Weight Rating)

Base Curb Weight

The base curb weight is the weight of the vehicle including fuel, coolants, lubricants, emergency tools and spare wheel and tire. It also includes any equipment that is standard. It does not include passengers, cargo or optional equipment installed by factory, dealer, aftermarket supplier or customer.

Payload

Maximum payload is the combined, maximum allowable weight of cargo, occupants and optional equipment that the vehicle is designed to carry. It is the Gross Vehicle Weight Rating minus the base curb weight.

Driving Your Villager

Gross Vehicle Weight (GVW)

The Gross Vehicle Weight (GVW) is the total weight of the passengers, cargo and all equipment.

It is important to remember that GVW is not a limit or a specification, but actual weight. If an owner loads up the vehicle and weighs it, that's the GVW at that moment. If the owner adds on more of a load and weighs it again, that becomes the GVW.

Gross Vehicle Weight Rating (GVWR)

To avoid overloading your vehicle, never exceed the specified Gross Vehicle Weight Rating for your Villager. The GVWR is the maximum **allowable** weight of the vehicle when fully loaded including passengers, cargo and all equipment.

Gross Axle Weight Rating (GAWR)

We have all seen a car or a truck that is loaded down in the rear and riding high in the front. This is a dangerous condition that usually means that the rear suspension components are under severe strain and that vehicle handling is impaired. There is more to carrying a load than just payload or GVWR.

Your Safety Compliance Certification Label not only gives the GVWR, it also gives the Gross Axle Weight Rating (GAWR) which is the maximum weight allowed on each axle system.

The rating is based on the carrying capacity of the weakest axle and suspension component as well as other factors. This is why it is so important to observe vehicle loading ratings.

Overloading a vehicle punishes components and can lead to shortened service life or outright failure.

The weakest link in the suspension system defines the GAWR, and may be the tires. Tires are rated to carry a specific maximum load at a specific tire pressure.

When passenger car tires are installed on light trucks and multipurpose passenger vehicles, they are rated at a 10% lower load carrying capacity due to the differences in vehicle usages.

With the tires inflated to the specified pressure, the total weight of your vehicle must not exceed the GVWR and GAWR specified on the Safety Compliance Certification Label. This includes full fuel tank(s), vehicle equipment, and occupants, as well as the cargo load.

Gross Combined Weight Rating (GCWR)

The GCWR is the maximum allowable weight of the towing vehicle and the loaded trailer (including all cargo and passengers).

Driving Your Villager

Calculating the Payload for Your Vehicle

To know how much weight your vehicle can carry:

1. Obtain the GVWR and GAWR from your Safety Compliance Certification Label.

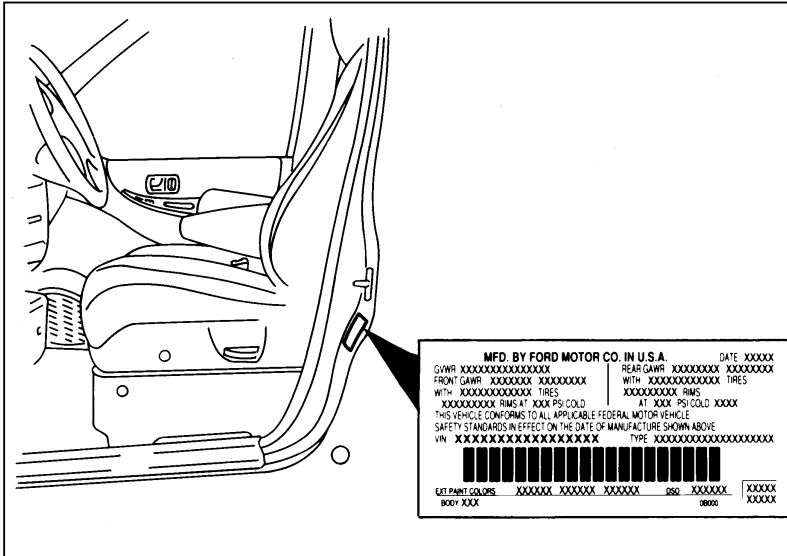

Safety Compliance Certification Label location

2. Fill the fuel tank.
3. Weigh your vehicle without cargo.
4. Subtract vehicle actual weight from the GVWR to find out how much more weight your vehicle can carry.
5. Weigh the vehicle again once it is loaded to make sure that the GVWR and front and rear GAWR's are not exceeded.

Load Calculation — (Trailers)

The trailer towing table shows the maximum allowable trailer weight and maximum GCWR for vehicles with and without the trailer towing package.

For a particular vehicle, the allowable trailer weight may be lower depending upon the vehicle's actual gross vehicle weight. (GVW is the weight of the vehicle including passengers, equipment, cargo.)

You must determine the appropriate trailer weight for your vehicle at its particular GVW while adhering to GVWR, GAWR, GCWR and maximum trailer weight ratings.

- Fill the fuel tank.
- Load the vehicle as it would be loaded when towing a trailer (including cargo, trailer hitch, etc.).
- Weigh the vehicle to determine its GVW. Do not exceed GVWR and GAWR.
- Obtain the appropriate GCWR from the trailer towing table.
- Subtract the loaded vehicle weight (GVW) from the GCWR. This is the maximum trailer weight your vehicle can pull given its particular GVW.

Driving Your Villager

Trailer towing table

	Without Trailer Towing Package	With Trailer Towing Package
Maximum trailer weight	2,000 lbs. (907 Kgs.)	3,500 lbs. (1,587 Kgs.)
Maximum GCWR	6,850 lbs. (3,107 Kgs.)	8,000 lbs. (3,628 Kgs.)

If your vehicle exceeds the GVWR, remove cargo from your vehicle accordingly. If your vehicle exceeds either GAWR, shift the load or remove cargo accordingly.

To determine actual GCW, weigh the total vehicle and trailer and also weigh the trailer separately to verify its weight.

Trailers

Towing a trailer safely means having the proper weight on the tongue (usually 10-15% of the trailer weight).

⚠ WARNING

If the GVWR or the GAWR specified on the Safety Compliance Certification Label is exceeded, your vehicle may be damaged or you may lose control and injure someone.
--

⚠ WARNING

Towing trailers beyond the maximum recommended gross trailer weight exceeds the limits of the vehicle and could result in engine damage, transaxle/axle damage, structural damage, loss of control, and personal injury.

Preparing to Tow

For your safety and for the good of your vehicle, use the right equipment for the type of trailer you tow. Also, make sure that all towing equipment is properly attached to your vehicle. If you are not certain that you are using the right equipment in the proper manner, see your dealer or a reliable trailer dealer.

Hitches

For towing trailers up to 2,000 lbs. (907 kg), use a good weight-carrying hitch and hitch ball which uniformly distributes the trailer tongue load through the underbody structure.

An optional trailer towing package is available for towing trailers up to 3,500 lbs. (1587 kg). Use a frame-mounted weight distributing hitch for trailers over 2,000 lbs. (907 kg).

Do not use single clamp bumper hitches or hitches that attach to the axle.

Whenever a trailer hitch and hardware are removed, make sure all mounting holes in the underbody are properly sealed to prevent exhaust fumes from entering the vehicle.

Safety chains

Always use safety chains between your vehicle and trailer. Cross chains under the trailer tongue and allow slack for turning corners. Connect safety chains to the vehicle frame or hook retainers. **Never attach chains to the bumper.**

Driving Your Villager

Trailer Brakes

Separate trailer brakes are required on most trailers weighing over 1,500 lbs. (680 kg).

WARNING

Do not connect a trailer's hydraulic brake system directly to your vehicle's brake system. Your vehicle may not have enough braking power and your chances of having a collision greatly increase.

Trailer Lamps

Make sure your trailer lamps conform to federal and local regulations.

Class I Trailer Tow electrical wiring provides two circuits (right hand and left hand) to operate trailer stop/turn tail lamps. Each stop/turn circuit will operate one combination stop/turn light bulb (# 1157, 3157, 2357, or 3357) on the trailer. Never add more than one trailer light bulb to one circuit.

WARNING

Always replace a fuse with one that has the specified amperage rating. Using a fuse with a higher amperage rating can cause severe wire damage and could start a fire.

Trailer Tow Module (If equipped)

The trailer tow module on your vehicle (if equipped) allows turn/stop lamp control on a trailer being towed by your vehicle.

The trailer tow package includes:

- trail or tow module which draws power from the vehicle stop lamp fuse

-
- one SAE J1239 specified connector
 - one extension harness within the rear bumper

If you need further assistance in wiring a trailer to your vehicle, contact your Ford or Lincoln-Mercury dealer.

Driving While You Tow

Be especially careful when driving while you tow a trailer. Never drive faster than 45 mph (70 km/h) when you tow in hilly country on hot days. Also, anticipate stops so that you can brake gradually.

If you use the speed control while you are towing on very long, steep grades, the speed control may shut off automatically.

When descending a steep grade with a trailer, operate in Drive rather than Overdrive. If additional braking is needed, shift into 2 (Second) or 1 (First) gear.

Servicing your vehicle if you tow

If you tow a trailer for a long distance, your vehicle will need to be serviced more frequently than usual. See the *Maintenance Schedule and Record* booklet in the Owner's portfolio.

Trailer towing tips

Before starting on a trip, practice turning, stopping and backing in an area away from heavy traffic. Get to know the "feel" of the vehicle/trailer combination.

Practice backing up. Back up very slowly, with someone outside at the rear of your trailer to guide you. Place your hand at the bottom of the steering wheel and move it in the direction you want the rear of the trailer to swing. Slight movement of the steering wheel results in a much larger movement of the rear of the trailer.

When turning, drive slightly beyond the normal turning point so the trailer wheels will clear curbs or other obstructions.

Driving Your Villager

Allow more room for stopping with a trailer attached. Trailer brakes should be applied first, whether manually or automatically controlled, when approaching a stop.

For an easy-to-operate vehicle/trailer combination, the trailer tongue load should be approximately 10-15% of the loaded trailer weight.

Make a thorough check of your equipment before starting out on the road. After you have traveled about 50 miles (80 km), stop in a protected area and double-check your hitch and electrical connections. Also check trailer wheel lug nuts for tightness.

When stopped in traffic for long periods of time in hot weather, place the gearshift selector lever in Park (P) to increase the engine idle speed. This aids in engine cooling and air conditioner efficiency. If the engine overheats, press the air intake button to select the fresh air position to stop the air conditioner compressor. Increase the engine speed for a short time.

Vehicles with trailers should not be parked on a grade. However, if you must park on a grade, place wheel chocks under the trailer's wheels as follows:

1. Apply the main brake pedal with your foot and hold it.
2. Have another person place the wheel chocks under the trailer wheels.
3. With the chocks in place, release the brake pedal, making sure the chocks are holding.
4. Apply the parking brake by pressing the main brake pedal down firmly with your right foot while depressing the parking brake pedal with your left foot.
5. Shift the gearshift lever into P (Park).

To start, after being parked on a grade:

1. Apply the main brake pedal with your foot and hold it.
2. Start the engine.
3. Shift the gearshift lever into gear and release the parking brake.
4. Release the main brake pedal and move the vehicle uphill to free the wheel chocks.
5. Apply the main brake pedal and hold while another person retrieves the chocks.

Roadside Emergencies

Jump-Starting Your Battery

Your vehicle's battery may discharge if you leave the lights or any electrical equipment on after you turn the engine off. If this happens, you may be able to jump-start from a booster battery to start your vehicle.

 **WARNING**

The gases around the battery can explode if exposed to flames, sparks, or lit cigarettes. An explosion could result in injury or vehicle damage.

 **WARNING**

To protect yourself when charging a battery, always shield your face and eyes. Make sure that you can breathe fresh air.

 **WARNING**

Applying too much pressure on the ends when lifting a battery could cause acid to spill. Lift the battery with a carrier or with your hands on the opposite corners.

 **WARNING**

Batteries contain sulfuric acid which burns skin, eyes, and clothing.

If the acid touches someone's skin, eyes, or clothing, immediately flush the area with water for at least 15 minutes. If someone swallows the acid, have him or her drink lots of milk or water first, then Milk of Magnesia, a beaten egg, or vegetable oil. Call a doctor immediately.

⚠ WARNING

Batteries contain sulfuric acid which burns skin, eyes, and clothing.

To avoid damaging your vehicle or your battery, and to avoid injury to yourself, follow these directions for preparing your vehicle to jump-start and connecting the jumper cables in the order they are given. If in doubt, call for road service.

Preparing Your Vehicle

1. Your vehicle has a 12-volt starting system, so you need to use a 12-volt jumper system. You will damage your starting motor, ignition system, and other electrical parts if you connect them to a 24-volt power supply (either two 12-volt batteries in series or a 24-volt generator set).
2. Do not disconnect the battery of the disabled vehicle. You could damage the vehicle's electrical system.
3. Park the booster vehicle close to the hood of the disabled vehicle. **Make sure the vehicles do not touch each other.** Set the parking brake on both vehicles and stay clear of the engine cooling fan and other moving parts.
4. Check all battery terminals and remove any excessive corrosion before you attach the jumper cables.
5. Turn on the heater blower in both vehicles. Turn off all other switches and lights in both vehicles to prevent possible damage to either vehicle's electrical systems.

Roadside Emergencies

Connecting the jumper cables

1. Connect one end of the first jumper cable to the positive (+) terminal of the discharged battery. (You can connect either jumper cable to the positive (+) terminal, as long as you use the same cable for both positive terminals.) Most jumper cables have a red cable and a black cable. The red cable is generally used for the positive terminals and the black for the negative ones.
2. Connect the other end of the first cable to the positive (+) terminal of the booster battery.
3. Connect one end of the second cable to the negative (-) terminal of the booster battery — NOT to the discharged battery.
4. Connect the other end of the second cable to a good metallic surface on the engine or frame of the disabled vehicle.

 WARNING
--

<p>Do not connect the end of the second cable to the negative (-) terminal of the battery to be jumped. A spark may cause an explosion of the gases that surround the battery.</p>

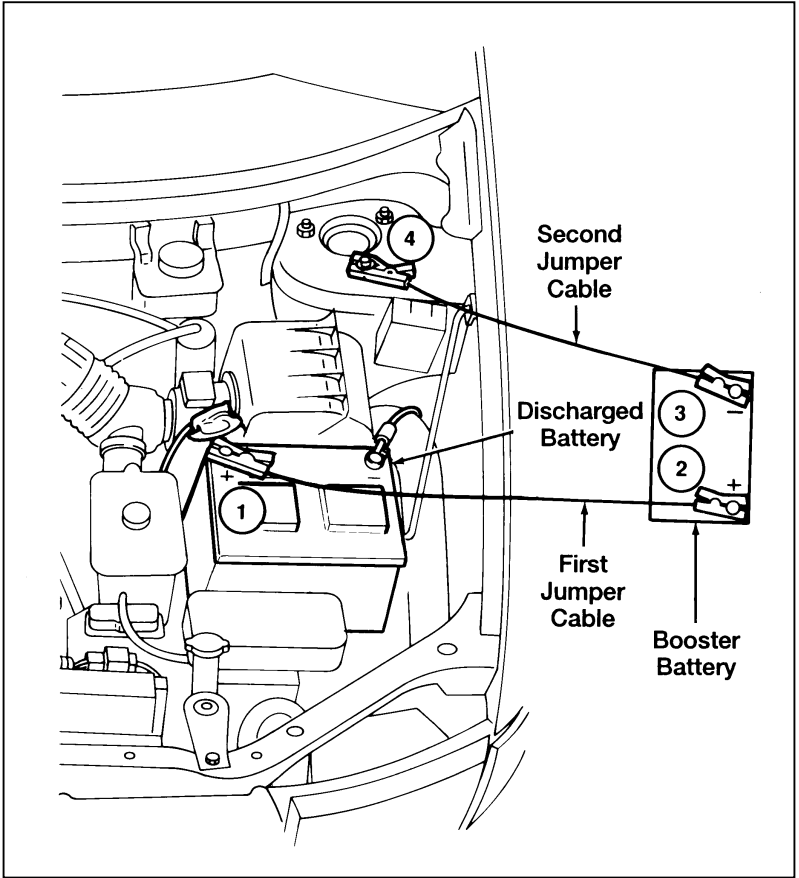

Sequence for connecting jumper cables

Roadside Emergencies

Jump-Starting

1. Make sure that the jumper cables are not in the way of moving engine parts, then start the booster vehicle. Run the engine at a moderate speed.
2. Let the discharged battery charge for a few minutes and then start the disabled vehicle. It may take a couple of tries before the vehicle starts. If the vehicle does not start after several attempts, there may be a different problem.
3. When both vehicles are running, let them idle for a few minutes to charge the discharged battery.

Removing jumper cables

1. **Always remove the jumper cables in the reverse order.** Remove the negative (–) end of the jumper cable from the metallic surface on the engine or frame of the disabled vehicle.
2. Remove the negative (–) cable from the booster battery.
3. Remove the positive (+) cable from the booster battery.
4. Remove the other end of the positive (+) cable from the discharged battery.

If you need to replace your battery, see *Battery* in the *Servicing Your Villager* chapter.

Changing a Flat Tire

If you get a flat tire while you are driving, do not apply the brake heavily. Instead, gradually decrease the speed. Hold the steering wheel firmly and slowly move to a safe place on the side of the road. Park on a level spot, turn off the ignition, set the parking brake, and turn on the hazard flashers.

The Temporary Spare Tire

Your vehicle has a temporary spare tire (unless you ordered the optional full-size spare tire). This spare tire is smaller than a regular tire and is designed for emergency use only. Use it only when you get a flat tire and replace it as soon as you can. This spare tire is marked with the words TEMPORARY USE ONLY so that you can easily identify it.

<p style="text-align: center;"> WARNING</p>

<p>If you use the temporary spare tire continuously or do not follow these precautions, the tire could fail, causing you to lose control of the vehicle, possibly injuring yourself or others.</p>

When you drive with the temporary spare tire, DO NOT:

- exceed 50 mph (80 km/h) under any circumstances
- load your vehicle so that it is heavier than the maximum vehicle load rating listed on the tire decal
- tow a trailer
- use tire chains
- try to repair the temporary spare tire or remove it from its wheel
- use the wheel for any other type of vehicle
- drive through an automatic car wash. Because the temporary spare tire is smaller than a conventional tire, it reduces the ground clearance. Your vehicle may get caught in the rails and it could be damaged.

Roadside Emergencies

Spare Tire Location

The spare tire is stored underneath your vehicle.

To remove the spare tire:

1. Open the liftgate and find the plastic hex nut cover in the carpeting of the cargo area. Lift the cover to expose the hex nut.

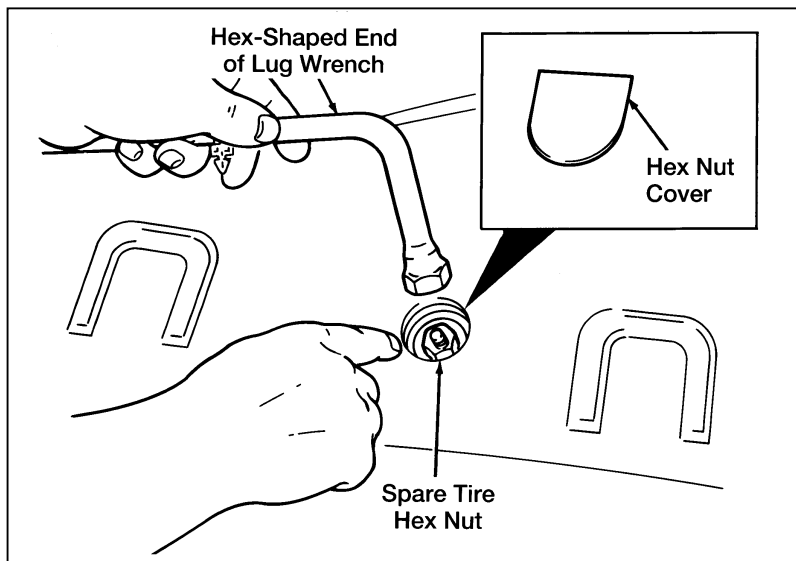

The spare tire hex nut

2. Find the tapered lug wrench in the tool kit located behind the jack in the right cargo area side panel.
3. Fit the hex-shaped end of the lug wrench over the hex nut in the floor of the cargo area. Turn counterclockwise until the cable extends far enough to lower the spare tire to the ground.

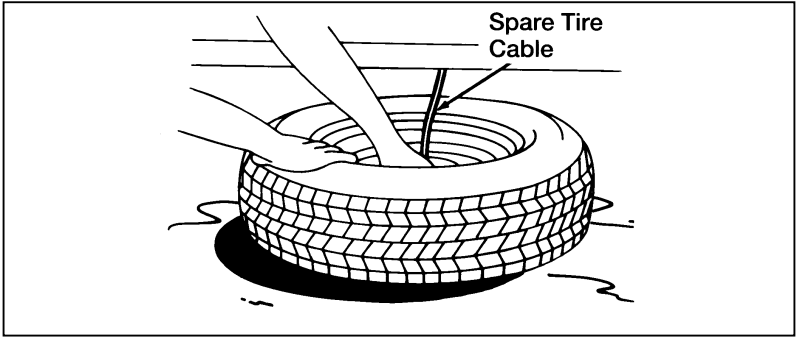

The spare tire in the lowered position

4. Continue to turn the hex nut counterclockwise until the spare tire retainer can be seen for removal.
5. Remove the retainer from the center of the wheel. It may be necessary to lift one end of the tire to disengage the retainer.

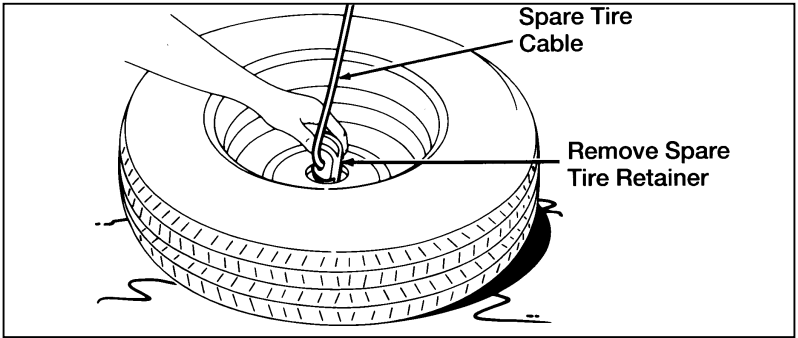

Removing the spare tire retainer

Roadside Emergencies

Stowing the spare tire

1. To raise the tire to the stowed position, lay the tire on the ground with the inboard side facing up. Install the retainer through the wheel center and slide the tire under the vehicle. Fit the hex-shaped end of the wheel lug wrench over the hex nut in the floor of the cargo area. Turn the wheel lug wrench clockwise until the tire is raised to its original position underneath the vehicle.

NOTE: The lug wrench ratchets when the tire is raised to the stowed position. It will not allow you to over-tighten.

2. Check for proper seating against the underbody supports and retighten if necessary.

 WARNING
--

Make sure spare tires and jacking equipment are stowed and secured in the proper storage location.

Preparing to Change the Tire

You should only raise your vehicle with a jack properly placed at the front or rear jacking points.

1. Make sure that your vehicle will not move or roll. Put the gearshift lever in P (Park). Set the parking brake and block the wheel — in both directions — that is diagonally opposite the tire that you are changing.

 WARNING
--

When one of the front wheels is off the ground, the transaxle alone will not prevent the vehicle from moving or slipping off the jack, even if the vehicle is in P (Park).

⚠ WARNING

To prevent the vehicle from moving when you change a tire, be sure the parking brake is set, then block (in both directions) the wheel that is diagonally opposite (other side and end of the vehicle) to the tire being changed.

⚠ WARNING

If the vehicle slips off the jack, you or someone else could be seriously injured.

2. Get out the spare tire and jack. See previous section for instructions on spare tire removal. The jack is located in the rear storage compartment in the right door panel of the cargo area. You will have to unfasten the jack before removing it as shown in the illustration.

NOTE: All occupants should be out of the vehicle while it is on the jack.

Roadside Emergencies

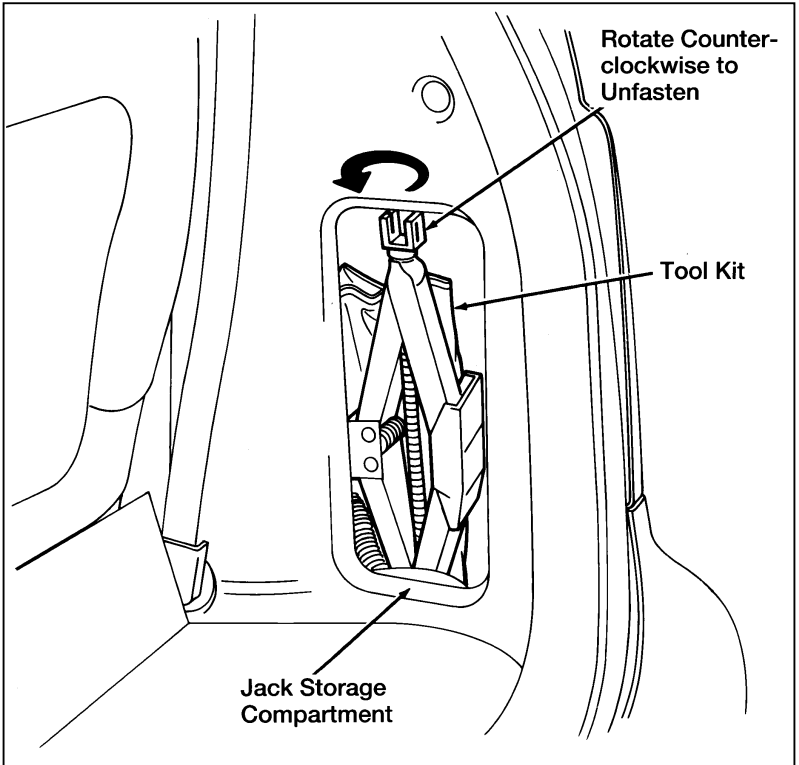

Jack storage location

3. Insert the tapered end of the jack handle behind the wheel cover of the tire to be changed and gently pry it off. When you want to replace the wheel cover, simply align the valve stem to the slot in the cover and press it back on.

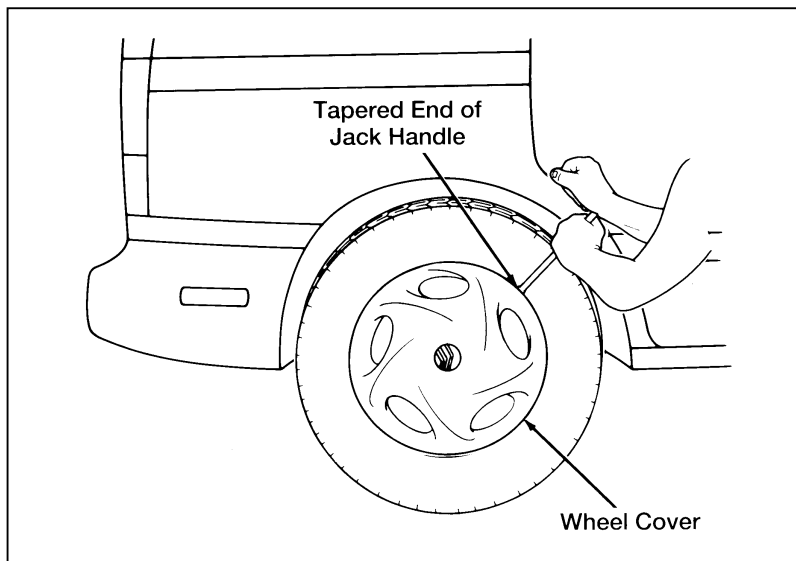

Removing the wheel cover

If you have the optional cast-aluminum wheel covers, remove the wheel cap to gain access to the lug nuts. Insert the tapered end of the jack handle behind the notch in the wheel cap and gently pry it off. To replace it, press it back on. You must line up the raised circle on the back of the wheel cap with the indented area on the wheel in order to press the wheel cap on.

Roadside Emergencies

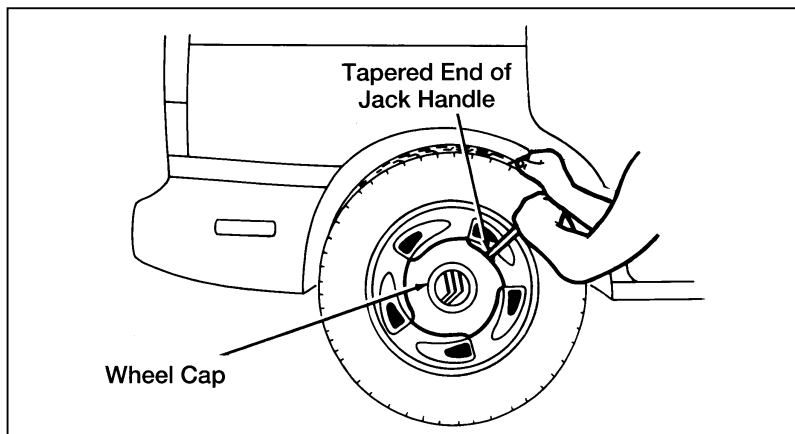

Removing the optional wheel cap

4. Fit the hex-shaped end of the lug wrench over the wheel lug nuts and loosen them one-half turn (counterclockwise). Do not remove the wheel lug nuts until you raise the tire off the ground.

If your vehicle has the optional locking lug nuts, you must use the lug nut removal tool provided with your vehicle's tool kit.

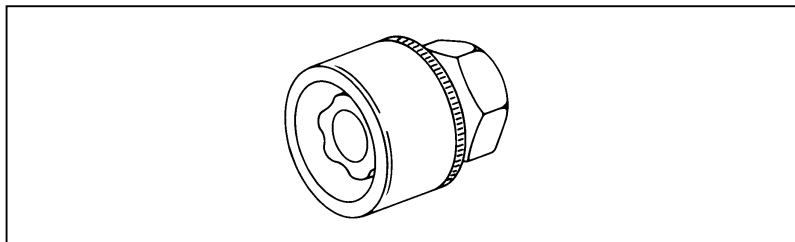

Anti-theft lug nut

5. Fit the jack under the proper jacking point indicated by the notch in the bottom of the door frame panel.

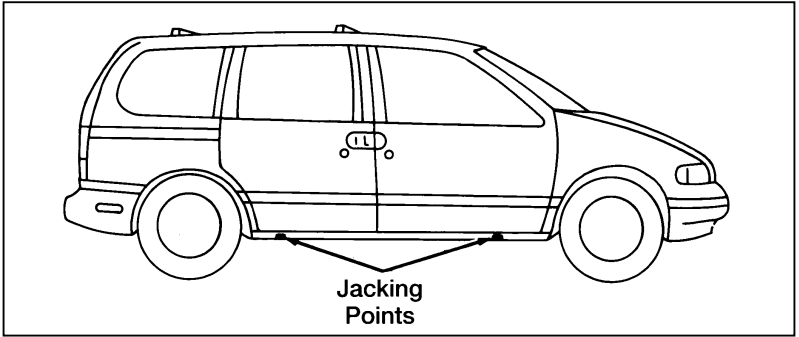

The notches for the jack

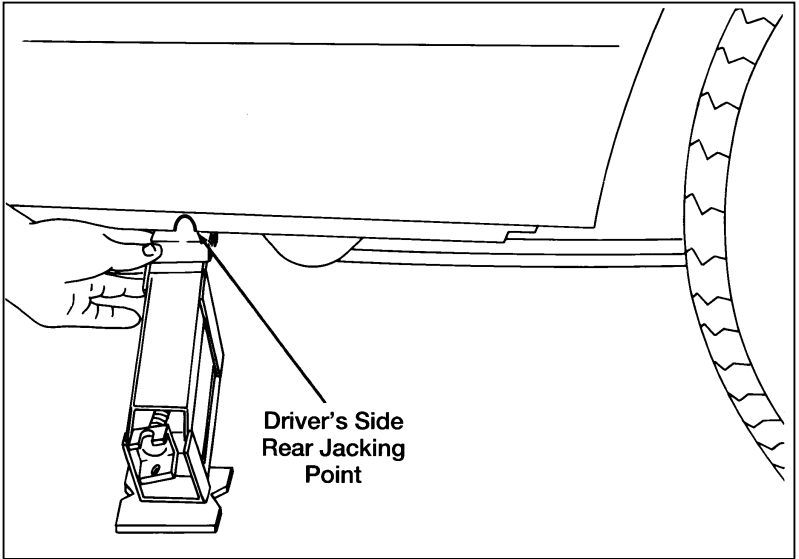

Placing the jack

Roadside Emergencies

⚠ WARNING

Do not jack on the running board.

⚠ WARNING

To avoid injury, never run the engine with one wheel off the ground, such as when changing a tire.

⚠ WARNING

To lessen the risk of personal injury, do not put any part of your body under the vehicle while changing a tire. Do not start the engine when your vehicle is on the jack. The jack is only meant for changing the tire.

⚠ WARNING

Never raise your vehicle by using a bumper jack. The bumper could be damaged or the jack could slip and you could be injured.

6. Insert the jack handle into the jack, and then slide the tapered end of the jack handle through one of the slots in the lug nut wrench. All of these tools are needed to jack up a vehicle.

NOTE: If Ford Accessory Running Boards have been installed, use the jack adapters supplied with the running boards as described on the inside of the jack storage area cover.

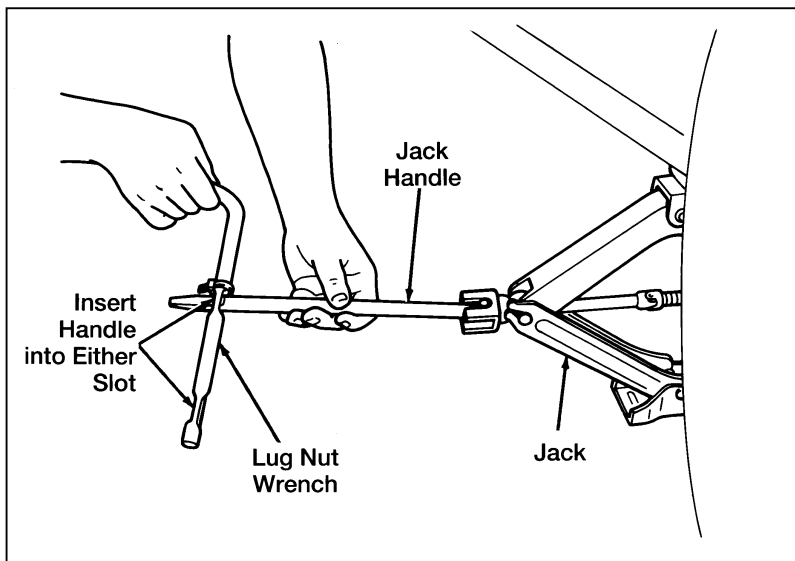

The jack and handle assembly

7. Turn the lug nut wrench (attached to the jack handle) clockwise to raise the vehicle off the ground.
8. Remove the wheel lug nuts with the lug nut wrench.
9. Remove the flat tire and replace it with the spare tire.
10. Place the wheel lug nuts on the spare tire. Use the lug nut wrench to screw the lug nuts snug against the wheel, but do not tighten fully.
11. Lower the vehicle by turning the jack handle counterclockwise.
12. Use the wheel lug wrench to tighten lug nuts in the appropriate sequence. Re-check for complete tightness.

Roadside Emergencies

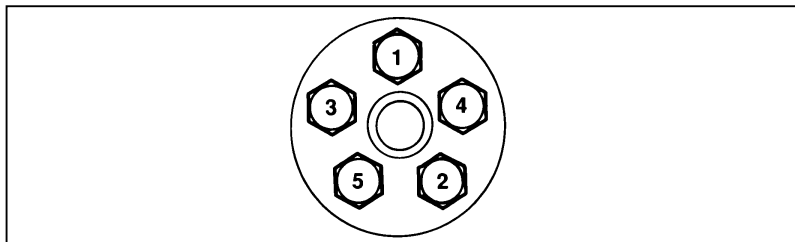

Lug nut tightening sequence

The lug nuts should be tightened to 72—87 ft-lb (98—118 N.m).

WARNING

Using wheels or lug nuts different than the original equipment could damage the wheel or mounting system. This damage could allow the wheels to come off while the vehicle is being driven. If a wheel comes off while the vehicle is in motion, it could cause loss of vehicle control and may result in collision.

13. Replace the wheel cover by pressing it into place. If you have the standard wheel covers, you must align the notch in the wheel cover with the tire's valve stem and align the recess in the back of the wheel cover with one of the lug nuts. If you have the optional aluminum wheel, press the center wheel cap into place after matching up the design of the wheel cap to the wheel.
14. Make sure the jack is securely fastened. When you replace the jack in the jack storage compartment, place the base against the square-shaped fastening bracket and open the jack slightly so that the jack is snug against the fastening brackets.
15. Store the flat tire under the vehicle just as you would store the spare tire. Refer to the section on *Stowing the Spare Tire* in this chapter.

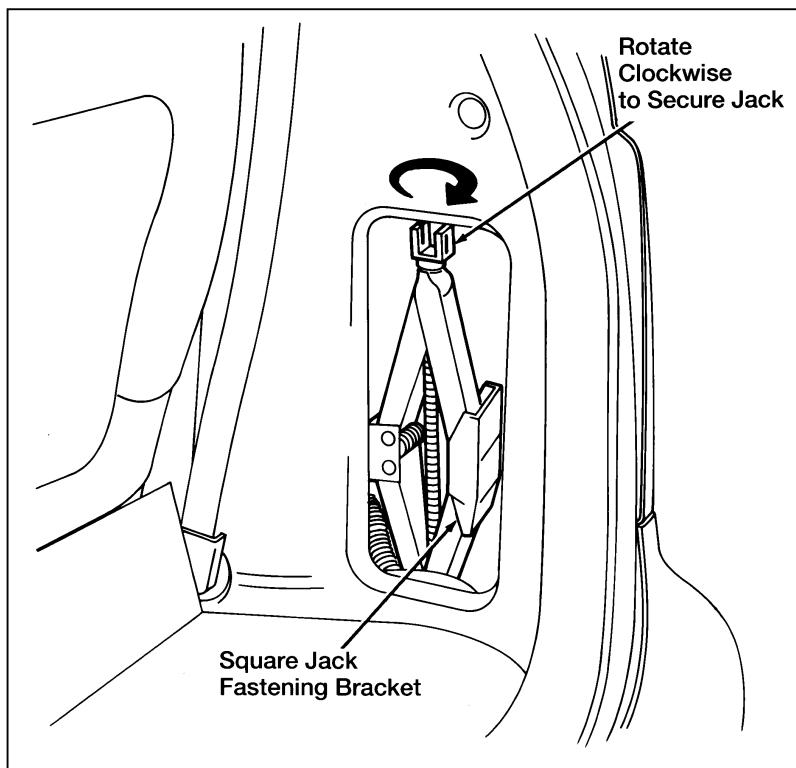

Storing the jack

16. Make sure the lug wrench is secured back into the tool kit and store it next to the jack.
17. Unblock the wheels.

Retighten the lug nuts to the specified torque at 500 miles (800 km) of operation, after any wheel change, or any time the lug nuts are loosened.

Roadside Emergencies

Fuel Pump Shut-Off Switch

If the engine cranks but does not start or if you have had a collision, the fuel pump shut-off switch may have been triggered. The shut-off switch is a device that stops the fuel pump when your vehicle has been involved in a substantial jolt.

For information on how to check and reset the fuel pump shut-off switch, see *Fuel pump shut-off switch* in the Index.

Towing Your Vehicle

If you need to have your vehicle towed, contact a professional towing service or, if you are a member, your roadside assistance center.

DO NOT TOW YOUR VILLAGER WITH SLINGBELT EQUIPMENT. Ford Motor Company has not developed or approved a T-hook sling-type procedure. Use wheel lift or flatbed equipment.

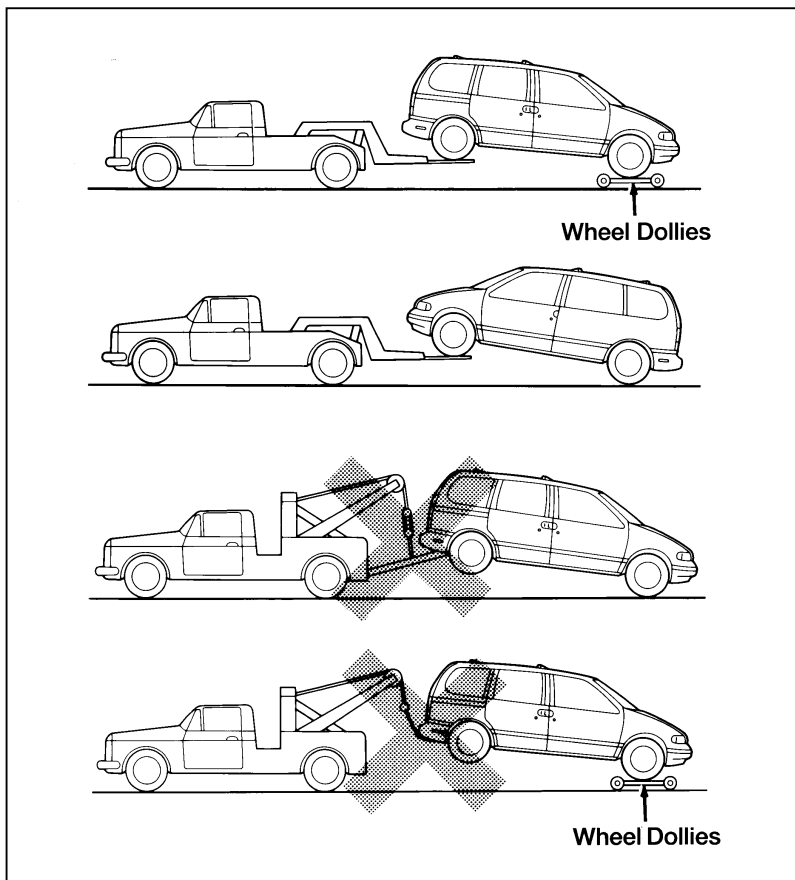

Towing the vehicle

When calling for a tow truck, tell the operator what kind of vehicle you have. A towing manual is available from Ford Motor Company for all authorized tow truck operators. Have your tow truck driver refer to this manual for the proper hook-up and towing procedures for your vehicle.

Customer Assistance

Roadside Assistance

Ford Motor Company has set up a 24-hour, seven-day-a-week hotline with trained operators that put you in touch with the help you need if you experience a problem with your vehicle. This complimentary service is provided to you throughout your warranty period of 3 years or 36,000 miles (60,000 km), whichever comes first. To purchase Roadside Assistance coverages beyond this period (available through Ford Auto Club in the United States or Ford and Lincoln-Mercury dealers in Canada), contact your Ford or Lincoln-Mercury dealer. Additional Roadside Assistance coverage is unavailable in Puerto Rico and the Virgin Islands.

Roadside Assistance will cover the following:

- Mount your spare if you have a flat tire.
- Jump-start your battery if it is dead.
- Unlock your vehicle if you are locked out.
- Bring you fuel if you run out.
- Tow your vehicle if you are stranded. Even non-warranty related tows, like accidents or getting stuck in mud or snow, are covered (some exclusions apply, such as impound towing and repossession).

How to use Roadside Assistance

Your Roadside Assistance identification card can be found in the Owner Guide portfolio in your glove compartment. Complete the card and place it in your wallet for quick reference.

To receive roadside assistance in the United States call 1-800-241-FORD (in Canada call 1-800-665-2006).

Should you need to arrange for roadside assistance yourself, Ford Motor Company will reimburse the reasonable cost. To obtain information about reimbursement call 1-800-241-FORD (in Canada call 1-800-665-2006).

If You Have a Service Concern

Ford Motor Company has authorized Ford and Lincoln-Mercury dealerships to service your vehicle. This section tells you how to get service or maintenance for your vehicle.

Service/Maintenance Concerns (U.S. or Canada)

Ford recommends taking your vehicle to your selling dealer who wants to ensure your continued satisfaction. You may, however, take your vehicle to any authorized Ford or Lincoln-Mercury dealer. In most cases, your dealer will be able to resolve your concern.

If you are not satisfied with the service you received from your dealership's service department, talk to the service manager at the dealership. If you still are not satisfied, talk to the owner or general manager of the dealership. In most cases, you will have your concern resolved at this level.

If you are away from home when your vehicle needs to be serviced, or if you need more help than the dealer gave you, contact the Ford Customer Assistance Center to find an authorized dealership that may be able to help you.

<p>Ford Motor Company Customer Assistance Center 300 Renaissance Center P.O. Box 43360 Detroit, Michigan 48243 1-800-392-3673 (FORD) TDD for the hearing impaired: 1-800-232-5952</p>

If you live in Canada and have any questions or concerns that the dealership cannot answer, contact the Customer Assistance Centre.

Customer Assistance

Customer Assistance Centre
Ford Motor Company of Canada, Limited
P.O. Box 2000
Oakville, Ontario L6J 5E4
1-800-565-3673 (FORD)

If you live in the U.S. and have any questions or concerns that the dealership cannot answer, contact the Customer Assistance Center.

To process your request, the Ford Customer Assistance Center needs the following information:

- your telephone number(s) (both business and home)
- the name of the dealer and the city where the dealership is located
- the year and make of your vehicle
- the date purchased
- the current mileage on your vehicle
- your 17-digit Vehicle Identification Number (VIN) (shown on your owner card)

If you still have a complaint involving a warranty dispute, you may wish to contact the Dispute Settlement Board (U.S. only) or the Canadian Motor Vehicle Arbitration Plan (CAMVAP) in Canada.

A warranty dispute must be submitted to the Dispute Settlement Board before taking action under the Magnuson-Moss Warranty Act, or to the extent allowed by state law, before pursuing replacement or repurchase remedies provided by

certain state laws. This dispute handling procedure is not required prior to enforcing state created rights or other rights which are independent of the Magnuson-Moss Warranty Act or state replacement or repurchase laws.

The Dispute Settlement Board (U.S. Only)

The Dispute Settlement Board is:

- an independent, third-party arbitration program for warranty disputes
- available free to owners and lessees of qualifying Ford Motor Company vehicles

The Dispute Settlement Board may not be available in all states. Ford Motor Company reserves the right to change eligibility limitations, modify procedures and/or discontinue this service without notice and without incurring obligations.

What Kinds of Cases Does the Board Review?

The Board reviews all warranty performance complaints on Ford, Mercury and Lincoln cars and Ford and Mercury light trucks under the new vehicle limited warranty that have not been resolved by either a dealer or Ford Motor Company, except those involving:

- a non-Ford product
- a non-Ford dealership
- a vehicle sales transaction
- request for reimbursement of consequential expenses. Expenses incidental to the warranty complaint being reviewed are eligible for consideration
- items not covered by the new vehicle limited warranty
- items covered by a service contract

Customer Assistance

- alleged liability claims
- property damage where the damage is significant when compared to the economic loss alleged under the warranty dispute
- cases currently in litigation
- vehicles not used primarily for family, personal or household purposes (except in states where the Dispute Settlement Board is required to review commercial vehicles)

Complaints involving vehicles in which applicable new vehicle limited warranties have expired at receipt of your application are not eligible. Eligibility may differ according to state law. For example, see the unique brochures for California and Wisconsin purchasers/lessees.

How does the Board Work?

The Board consists of:

- three consumer representatives
- a Ford or Lincoln/Mercury dealer

Consumer candidates for Board membership are recruited and trained by an independent consulting firm. Dealers are chosen because of their business leadership qualities.

What the Board needs

To have your case reviewed you must complete the application in the DSB brochure and mail it to the address provided on the application form.

Your application is reviewed and, if it is determined to be eligible, you will receive an acknowledgment indicating:

- the file number assigned to your application
- the toll-free phone number of the DSB's independent administrator

Your dealership and a Ford Motor Company representative are asked to submit statements at this time.

To review your case properly, the Board needs the following information:

- legible copies of all documents and maintenance or repair orders relevant to the case
- the year, make, model and Vehicle Identification Number (VIN) listed on your vehicle ownership license
- the date of repair(s) and mileage at the time of occurrence(s)
- the current mileage
- the name of the dealer who sold or serviced the vehicle
- a brief description of your unresolved concern
- a brief summary of the action taken with the dealer and Ford Motor Company
- the names (if known) of all the people you contacted at the dealership
- a description of the action you expect to resolve your concern

Should your case NOT qualify for review, a letter of explanation will be mailed to you.

Oral presentations

If the involved vehicle is within 36 months and 36,000 miles of the warranty start date, you have the right to make an oral presentation before the Board. Indicate your choice to do so on the application. Oral presentations may also be requested by the Board.

Customer Assistance

Making a decision

Board members will review all available information related to the complaint, including oral presentations, if necessary. They then arrive at a fair and impartial decision, decided by a simple majority vote.

Because the Board usually meets only once a month, some cases may take longer than 30 days to be reviewed. The Board makes every effort to resolve each case within 40 days of receiving the consumer application form.

After a case is reviewed, the Board mails you a decision letter. The Board also provides a form on which to accept or reject the Board's decision. The decisions of the Board are binding on the dealer and Ford, but not on consumers who may elect to pursue other remedies available to them under state and federal law. Decisions of the Board may be presented as evidence by any party in subsequent legal proceedings that may be initiated, where allowed by law.

To Request a DSB Brochure/Application

For a brochure/application, speak to your dealer or write to the Board at the following address:

*Dispute Settlement Board
P.O. Box 5120
Southfield, MI 48086-5120*

Reporting Safety Defects (U.S. only)

If you believe that your vehicle has a defect which could cause an accident or could cause injury or death, you should immediately inform the National Highway Traffic Safety Administration (NHTSA) in addition to notifying Ford Motor Company.

If NHTSA receives similar complaints, it may open an investigation, and if it finds that a safety defect exists in a group of vehicles, it may order a recall and remedy campaign. However, NHTSA cannot become involved in individual problems between you, your dealer, or Ford Motor Company.

To contact NHTSA, you may either call the Auto Safety Hotline toll-free at 1-800-424-9393 (or 366-0123 in Washington, D.C. area) or write to: NHTSA, U.S. Department of Transportation, Washington, D.C. 20590. You can also obtain other information about motor vehicle safety from the Hotline.

Ford of Canada Customer Assistance

If you live in Canada and have any questions or concerns that the dealership cannot answer, contact the Customer Assistance Centre.

<p>Customer Assistance Centre Ford Motor Company of Canada, Limited P.O. Box 2000 Oakville, Ontario L6J 5E4 1-800-565-3673 (FORD)</p>
--

Customer Assistance

Please have the following information available when contacting the Customer Assistance Centre:

- your telephone number (both business and home)
- your Vehicle Identification Number (VIN) listed on your owner card and/or your vehicle ownership license
- the year and make of your vehicle
- the date purchased
- the name of the dealer and the city where the dealership is located
- the current mileage on your vehicle

Mediation/Arbitration Program

In those cases where you continue to feel that the efforts by Ford and the dealer to resolve a factory-related vehicle service concern have been unsatisfactory, Ford of Canada participates in an impartial third-party mediation/arbitration program administered by the Canadian Motor Vehicle Arbitration Plan (CAMVAP).

The CAMVAP program is a straight-forward and relatively speedy alternative to resolve a disagreement when all other efforts to produce a settlement have failed. This procedure is without cost to you and is designed to eliminate the need for lengthy and expensive legal proceedings.

In the CAMVAP program, impartial third-party Arbitrators conduct hearings at mutually convenient times and places in an informal environment. These impartial Arbitrators review the positions of the parties, make decisions and, where appropriate, render awards to resolve disputes. CAMVAP decisions are fast, fair and final as the arbitrator's award is binding on both you and Ford of Canada.

CAMVAP services are available in all territories and provinces, except Quebec. For more information, without charge or obligation, call your CAMVAP Provincial Administrator directly at 1-800-207-0685.

The CAMVAP program is a straight-forward and relative speedy alternative to resolve a disagreement when all other efforts to produce a settlement have failed. This procedure is without cost to you and is designed to eliminate the need for lengthy and expensive legal proceedings.

In the CAMVAP program, impartial third-party Arbitrators conduct hearings at mutually convenient times and places in an informal environment. These impartial Arbitrators review the positions of the parties, make decisions and, where appropriate, render awards to resolve disputes. CAMVAP decisions are fast, fair and final as the Arbitrator's award is binding on both you and Ford of Canada.

CAMVAP services are available in all territories and provinces, except Quebec. For more information, without charge or obligation, call your CAMVAP Provincial Administrator directly at 1-800-207-0685.

Getting Help Outside the U.S. and Canada

Before you export your vehicle to a foreign country, contact the appropriate foreign embassy or consulate to make sure local regulations do not prevent you from registering your vehicle. Officials at the embassy can also help you decide whether you should import your vehicle to that country.

Officials at the embassy or consulate can tell you where to get unleaded fuel. If you cannot get unleaded fuel or can get only fuel with an anti-knock index that is lower than your vehicle needs, contact a district or customer assistance center before you leave the U.S. or Canada.

Customer Assistance

Use of leaded fuel in your vehicle without a proper conversion may damage the effectiveness of your emissions control system and may cause engine knocking or serious engine damage. Ford Motor Company is not responsible for any damage that is caused by use of improper fuel.

You may also have difficulty importing your vehicle back into the U.S. if you use leaded fuel.

If your vehicle must be serviced while you are traveling or living in Central or South America, the Caribbean, or the Middle East, contact the nearest Ford dealership. If the dealership cannot help you, contact:

*FORD MOTOR COMPANY
WORLDWIDE EXPORT OPERATIONS
1555 Fairlane Drive
Fairlane Business Park #3
Allen Park, Michigan 48101
U.S.A.
Telephone: (313) 594-4857
Fax: (313) 390-0804*

If you are in other foreign countries, contact the nearest Ford dealership. If the dealership cannot help you, they can direct you to the appropriate Ford affiliate office.

If you buy your vehicle in North America and then relocate outside of the U.S. or Canada, register your Vehicle Identification Number and new address with Ford Motor Company Export Operations.

Ford Accessories for Your Villager

Ford has many fine products available from your dealer to clean your vehicle and protect its finishes. For best results, use the following, or products of equivalent quality:

- Ford Custom Clear Coat Polish
- Ford Custom Silicone Gloss Polish
- Ford Custom Vinyl Protectant
- Ford Deluxe Leather and Vinyl Cleaner
- Ford Extra Strength Spot and Stain Remover
- Ford Extra Strength Tar and Road Oil Remover
- Ford Extra Strength Upholstery Cleaner
- Ford Extra Strength Whitewall Tire Cleaner
- Ford Multi-Purpose Cleaner
- Ford Premium Car Wash Concentrate
- Ford Triple Clean
- Ford Ultra-Clear Spray Glass Cleaner

Many accessories for your vehicle are available through your local authorized dealer. These accessories have been designed to meet your needs and are custom-designed to complement the style and aerodynamics of your vehicle. Some of the available accessories are listed here.

Safety, Comfort, and Convenience

Comfort and Convenience

- Air Conditioning
- Engine Block Heater
- Remote Keyless Entry

Protection and Appearance Equipment

Aero Running Boards

Carpeted Floor Mats

Door Edge Guards

Cleaners, Waxes and Polishes

Front End Cover

Front End Mini Cover

Lubricants and Oils

Molded Running Boards

Side Window Shields

Soft Luggage Cover

Protection and Appearance Equipment (Continued)

Styled Wheel Protector Locks

Super Seal Fabric Protector (U.S. Only)

Super Seal Rustproofing (U.S. Only)

Super Seal Undercoating (U.S. Only)

Touch-Up Paints

Flat Splash Guards

Safety Equipment

Vehicle Security Systems

Travel Equipment

Aero Hood Deflector

Bike Rack Adaptor (Attaches to Base Roof Rack)

Four Season Base Roof Rack

Multi Sport Removable Rack

Multi Sport Bike Adaptor

Multi Sport Ski/Snowboard Adaptor

Multi Sport Water Sport Adaptor

Ski Rack Adaptor (Attaches to Base Roof Rack)

NOTE: When adding accessories, equipment, passengers, and luggage to your vehicle, do not exceed the total weight capacity of the vehicle or of the front or rear axle (GVWR, GAWR as shown on the Safety Compliance Certification Label). Consult your dealer for specific weight information.

NOTE: Devices that emit radio frequency (RF) energy such as AM/FM radios, mobile communication systems (two-way radios, telephones) and radio controlled security systems, are subject to the rules and regulations of the Federal Communications Commission (FCC) 47 CFR Parts 2 and 15. Any such system installed in your vehicle should comply with those rules and should be installed only by a qualified technician. In addition, to insure continued compliance with the FCC's requirements, RF devices must not be modified or changed in a manner not expressly approved by Ford Motor Company.

NOTE: Mobile communication systems, particularly if not properly installed, may adversely affect the operation of the vehicle. For example, such systems, when operated, may cause the engine to stumble or stall. In addition, such systems may themselves be damaged, or their operation affected, by the operation of the vehicle. (Citizens band [CB] transceivers, garage door openers, and other transmitters whose power output is 5 watts or less, ordinarily will not affect vehicle operation.)

NOTE: Because Ford has no control over the operation or manufacture of such systems or their installation, Ford cannot assume responsibility for any adverse effects or damage if this equipment is used.

1996 Villager Owner Manual Order Form

PUBLICATION FORM NO.	DESCRIPTION
FCS-12233-96	1996 Villager Service Manual
FCS-12106-96	1996 Powertrain Control/Emission Diagnosis
FCS-12137-96	1996 Light Truck Service Specifications
FCS-12220-96	1996 Villager Electrical & Vacuum Troubleshooting Manual
93-VID-OM	Ford and the American Dream (50) Minutes of Historic/Nostalgic Videotape

- **NOTE:** For publications prior to year shown above, write for availability to the address shown below.
- Please allow ample time for postal service delivery.

U.S. RESIDENTS

Make checks payable to: HELM, INCORPORATED

MAIL ORDER TO:

HELM, INCORPORATED
P.O. Box 07150
Detroit, Michigan 48207

OR ORDER TOLL FREE:

1-800-782-4356

Monday - Friday 8:00 A.M. - 6:00 P.M. EST, For Credit Card Holder Orders Only

CANADIAN RESIDENTS

Make cheques payable to: Ford Motor Company of Canada, Ltd.

MAIL ORDER TO:

Ford Motor Company of Canada, Ltd.
Service Publications
P.O. Box 1580, Station B
Mississauga, Ontario, Canada L4Y 4G3

OR ORDER TOLL FREE:

1-800-387-4966

Monday - Friday 8:30 A.M. - 6:00 P.M. EST, For Credit Card Holder Orders Only

Accessories

U.S.
RESIDENTS
USE THIS
PAGE

ORDER TOLL FREE 1-800-782-4356

NOTE: For Credit Card Holder Orders Only Monday-Friday 8:00 A.M. -6:00 P.M. EST

If further information is needed, write to the address shown below or call 1-800-782-4356. Material cannot be returned for credit without receiving advance authorization within 14 days of delivery. On returns, a re-stocking fee may be applied against the original order.

1 9 9 6	PUBLICATION FORM NUMBER	1996 VILLAGER PUBLICATION	QTY.	PRICE EACH	TOTAL PRICE
		FCS-12233-96	Villager SM		\$ 98.00
	FCS-12106-96	Powertrain Control/ED		160.00	
	FCS-12137-96	Light Truck Service Spec.		32.00	
	FCS-12220-96	Villager EVTM		36.00	
	93-VID-0M	Videotape		19.95	

**P
A
Y
M
E
N
T**

Check or Money Order payable to Helm, Inc. (USA funds only - do not send cash.)

MasterCard

VISA Discover

Expiration Date mo/yr: /

Account Number

(CUSTOMER SIGNATURE)

TOTAL MATERIAL		
Michigan Purchasers add 6% sales tax		
Handling Charge		\$4.00
GRAND TOTAL		

Check here if billing address is different from shipping address shown

**S
H
I
P
T
O**

NOTE: Dealers and Companies please provide dealer or company name, along with the name of the person to whom the shipment should be sent. For purchases outside U.S.A. and Canada, please write to the following address for quotation Mail completed order form to: HELM, INC • P.O. Box 07150 • Detroit, MI 48207 Please allow 6-8 weeks for delivery. Prices are subject to change without notice and without incurring obligation.

(CUSTOMER NAME) (ATTENTION)

(STREET ADDRESS - NO P.O. BOX NUMBERS) (APT.NO.)

(CITY) (STATE) (ZIP CODE)

DAYTIME TELEPHONE AREA CODE () _____

CANADIAN
RESIDENTS
USE THIS
PAGE

ORDER TOLL FREE 1-800-387-4966

NOTE: For Credit Card Holder Orders Only Monday-Friday 8:30 A.M.-6:00 P.M. EST

If further information is needed, write to the address shown below or call 1-800-387-4966. Material cannot be returned for credit without receiving advance authorization within 14 days of delivery. On returns, a re-stocking fee may be applied against the original order.

1 9 9 6	PUBLICATION FORM NUMBER	1996 VILLAGER PUBLICATION	QTY.	PRICE EACH	TOTAL PRICE
		FCS-12233-96	Service Manual		\$ 98.00
	FCS-12106-96	Powertrain Control/ED		160.00	
	FCS-12137-96	Light Truck Service Spec.		39.00	
	FCS-12220-96	Electrical & Vacuum T.M.		49.00	

P A Y M E N T	<input type="checkbox"/> Cheques or Money Order payable to Ford Motor Company of Canada, Ltd. (Do not send cash.)		TOTAL MATERIAL	
	<input type="checkbox"/> VISA		G. S. T. (7%)	
	Expiration Date mo/yr: <input type="text"/> <input type="text"/> / <input type="text"/> <input type="text"/>		Handling/Shipping Charge Individual Item Order Except Service Manuals \$5.00 OR Service Manuals and Multiple Item Orders \$10.00 (French Owner Guide: No Charge)	
	Account Number <input type="text"/> <input type="text"/> <input type="text"/> <input type="text"/> <input type="text"/> <input type="text"/> <input type="text"/> <input type="text"/> <input type="text"/> <input type="text"/> <input type="text"/> <input type="text"/> <input type="text"/> <input type="text"/> <input type="text"/> <input type="text"/> <input type="text"/> <input type="text"/> <input type="text"/> <input type="text"/>		GRAND TOTAL	
	<input type="checkbox"/> Check here if billing address is different from shipping address shown.			

(CUSTOMER SIGNATURE) _____ (DATE) _____

S H I P T O	NOTE: Dealers and Companies please provide dealer or company name, along with the name of the person to whom the shipment should be sent. Mail completed order form to: Ford Motor Company of Canada, Ltd. • Service Publications • P.O. Box 1580, Station B Mississauga, Ontario, Canada L4Y 4G3. Please allow 6-8 weeks for delivery. Prices are subject to change without notice and without incurring obligation.		
	_____		_____
	(CUSTOMER NAME)		(ATTENTION)
	_____		_____
	(STREET ADDRESS - NO P.O. BOX NUMBERS)		(APT.NO.)
	_____	_____	_____
(CITY)	(PROVINCE)	(POSTAL CODE)	
DAYTIME TELEPHONE	AREA CODE ()	_____	

Service Made Easy

Ford has two goals for servicing your vehicle.

1. When we can, we design parts that do not need to be serviced.
2. We want to make servicing your vehicle as easy as possible. To help you:
 - We highlight do-it-yourself items in yellow in your engine compartment so that you can find them easily.
 - When possible, we design parts — such as the headlamp bulbs — that can be replaced without tools.
 - We give you a Maintenance Schedule that makes tracking routine service for your vehicle easy. The Maintenance Schedule is located in the *Maintenance Schedule and Record* booklet.

This chapter tells you about the basic parts that you need to check and service regularly.

If your vehicle needs professional servicing, your dealership can provide the parts and service required. Check your *Warranty Information Booklet* to find out which parts and services are covered. Also see the *Customer Assistance* chapter of this Owner's Manual.

Ford Motor Company recommends that the Owner Maintenance Checks listed in the *Maintenance Schedule and Record* booklet be performed for the proper operation of your vehicle. In addition to the conditions listed in the Owner Maintenance Checklist, be alert for any unusual noise, vibration, or other indication that your vehicle may need service. If you do notice something unusual, see that your vehicle is serviced promptly.

Use only recommended fuels, lubricants, fluids, and service parts that meet Ford Motor Company specifications. Motorcraft parts are designed and built to provide the best performance in your vehicle. Using these parts for replacement is your assurance that Ford-built quality stays in your vehicle.

NOTE: Always dispose of used automotive fluids in a responsible manner. Follow your community's standards for disposing of these types of fluids. Call your local recycling center to find out about recycling automotive fluids.

Precautions When Servicing Your Vehicle

Be especially careful when inspecting or servicing your vehicle. Here are some general precautions for your safety:

- Your vehicle is equipped with an automatic cooling fan. It may come on at any time without warning. To avoid injury, always disconnect the negative (-) terminal of the battery before working near the fan.
- Do not work on a vehicle in an enclosed space with the engine running, unless you are sure you have enough ventilation.
- Never get under a vehicle while it is supported only by a jack. If you must work under a vehicle, use safety stands.
- Keep all lit cigarettes and other smoking materials away from the battery and all fuel-related parts.

Servicing Your Villager

If you plan to work under the hood while the engine is off:

WARNING

Set the parking brake and make sure the gearshift is securely latched in P (Park). This will prevent your vehicle from moving unexpectedly.
--

WARNING

Always remove the key from the ignition after you turn off the engine.

If you must work under the hood while the engine is on:

Set the parking brake fully and make sure that the gearshift is securely latched in P (Park). This will prevent your vehicle from moving unexpectedly.

WARNING

Do not start your engine with the air cleaner removed and do not remove it while the engine is running.
--

- If you must work with the engine running, avoid wearing loose clothing or jewelry that could get caught in moving parts. Take appropriate precautions with long hair.

Opening the Hood

1. Pull the hood release handle, located below the fuse panel door.

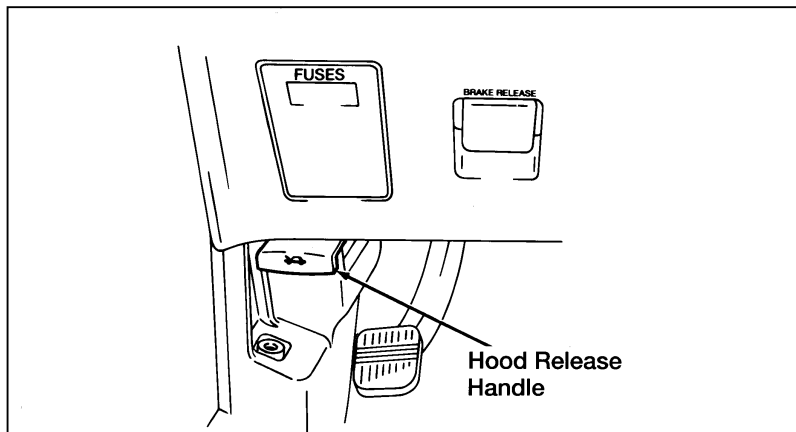

Hood release handle location

2. Go to the front of the vehicle and release the hood latch under the hood in the front center of the vehicle.

Servicing Your Villager

3. Lift the hood and release the prop rod from its retaining clip. Place the end of the prop rod in the prop rod hole provided on the underside of the hood.

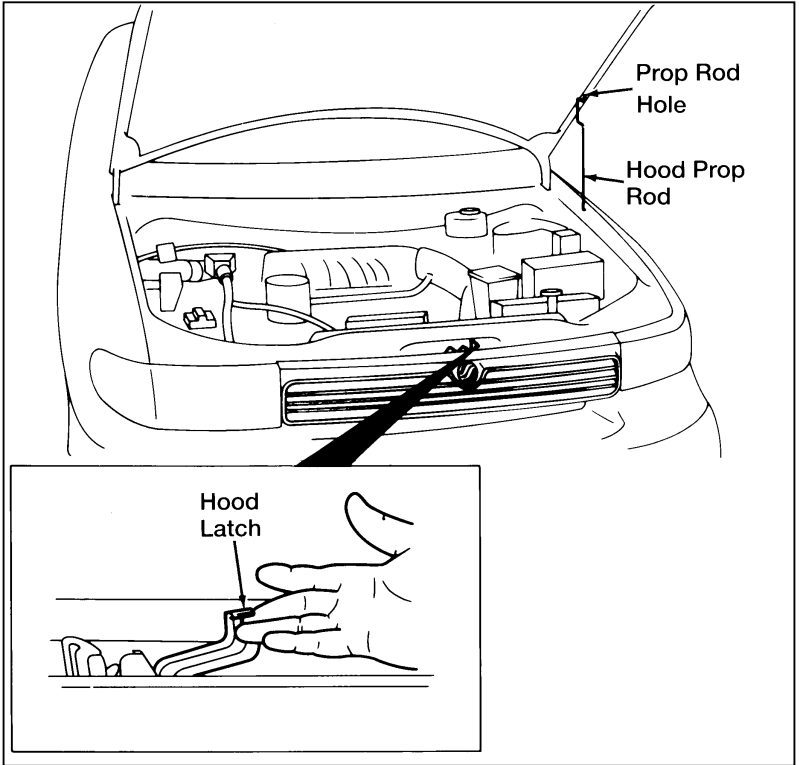

The hood latch and prop rod

To close the hood:

1. Remove the prop rod from the slotted hole in the hood. Place the rod in its retaining clip and close the hood with enough force to make it latch. Be sure to oil the hood latch every six months to maintain smooth operation.
2. Try to lift the hood after closing it to be sure it is securely latched.

Engine Compartment

Your vehicle has a 3.0 liter EFI, V-6 engine. The following illustration will show a diagram of your engine and where you can find items that you should service regularly.

1. Automatic Transaxle Fluid Dipstick
2. Engine Coolant Reservoir
3. Brake Fluid Reservoir
4. Air Filter
5. Battery
6. Left-Hand Engine Compartment Fuse and Relay Box
7. Radiator Cap
8. Engine Oil Filler Cap
9. Engine Oil Dipstick
10. Windshield Washer Fluid Reservoir
11. Right-Hand Engine Compartment Relay Box
12. Power Steering Fluid Reservoir

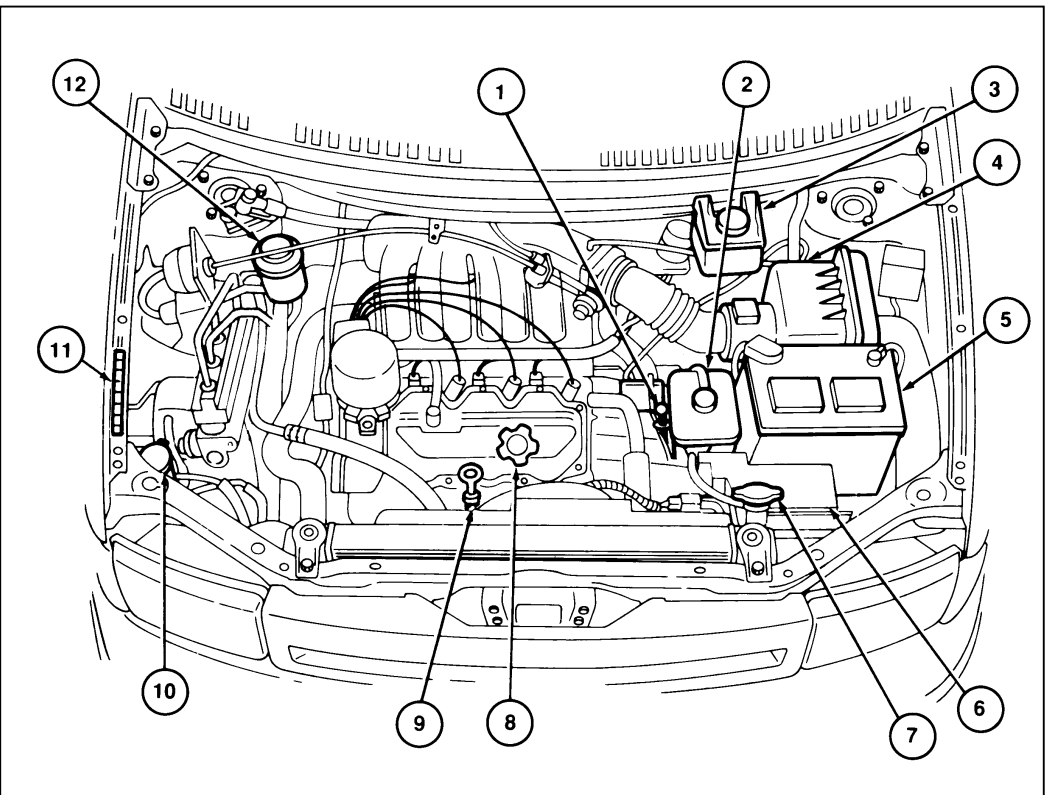

The engine compartment

Cleaning the Engine

A clean engine is more efficient because a buildup of grease and dirt acts as an insulator, keeping the engine warmer than normal.

- Extreme care must be used if a power washer is used to clean the engine. The high pressure fluid could penetrate sealed parts and assemblies causing damage or malfunctions.
- In order to avoid possible cracking of the engine block or fuel injection pump, do not spray a hot engine or injection pump with cold water.
- The alternator, distributor and air intake must be covered. Covering these components will help prevent water damage.
- Never wash or rinse the engine while it is running. Water getting into the engine may cause internal damage.

Servicing Your Villager

Filling the Fuel Tank

Removing the tethered fuel cap

1. Open fuel door on driver's side of vehicle.
2. Follow the fuel cap removal instructions and use caution to minimize the possibility of fuel spraying when you unscrew the cap.

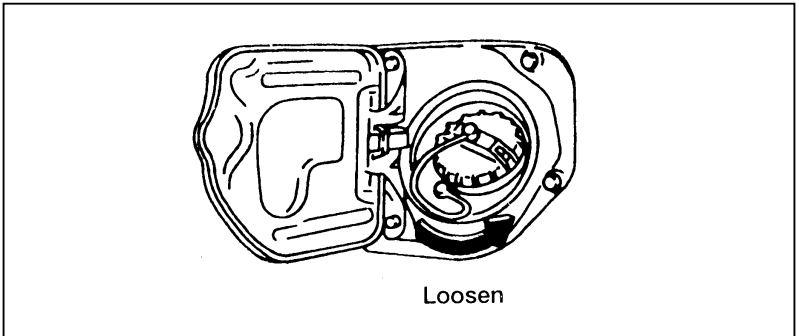

The tethered fuel cap

If you lose the fuel cap, replace it with an authorized Motorcraft or equivalent part.

WARNING

If you do not use the proper fuel cap, the pressure in the fuel tank can damage the fuel system or cause it to work improperly in a collision.

WARNING

If the fuel cap is venting vapor or if you hear a hissing sound, wait until it stops before completely removing the cap.

NOTE: If you replace your fuel cap with an aftermarket fuel filler cap, the customer warranty may be void for any damage to the fuel tank and/or fuel system.

A venting fuel tank is not an abnormal condition. It may be caused by:

- too volatile a fuel for the weather conditions. Service stations sometimes sell winter grade fuel in the summer.
- pulling a heavy load on hot days, or at high altitudes.
- extended periods of idling with the engine RPM increased above the normal idle range.
- parking the vehicle in full sunlight for extended periods on extremely hot days.

WARNING

<p>Do not overfill the fuel tank. The pressure in an overfilled tank may cause leakage and lead to fuel spray and fire.</p>
--

Before you fill your vehicle with fuel, extinguish all lit cigarettes, other smoking materials, and any open flames.

To fill the tank properly:

1. Remove the fuel cap. Proceed to add fuel to the tank only if your vehicle is on level ground.
2. Make sure you pump unleaded fuel and put the nozzle all the way inside the fuel filler pipe. The fuel tank is normally full after three automatic shutoffs of the nozzle.
3. If you spill any fuel on the body of your vehicle, clean it off immediately. The fuel may dull or soften the paint if you do not wash it off.

Service Your Villager

4. Replace the fuel cap tightly when you are finished. Turn it clockwise until you hear at least three clicks. The ratcheting mechanism allows the fuel cap to be sealed without overtightening.
5. Push the fuel door closed.

Choosing the Right Fuel

Use only UNLEADED FUEL. The use of leaded fuel is prohibited by law and could damage your vehicle. The damage may not be covered by your warranty.

Your vehicle was not designed to use fuel containing manganese-based additives such as MMT. Additionally, vehicles certified to California emission standards (indicated on the underhood vehicle Emissions Control Information label) are designed to operate on California reformulated gasolines. If California reformulated gasoline is not available when you refuel, your vehicle can be operated on non-California fuels. However, even though your engine will perform adequately on other gasolines, the performance of the emission control devices and systems may be adversely affected. Repair of damage caused by using a fuel that your vehicle was not designed for may not be covered by your warranty.

Octane recommendation

Your vehicle is designed to use regular gasoline with an (R+M)/2 octane rating of 87. We do not recommend gasolines labeled as “regular” in high altitude areas that are sold with octane ratings of 86 or even less.

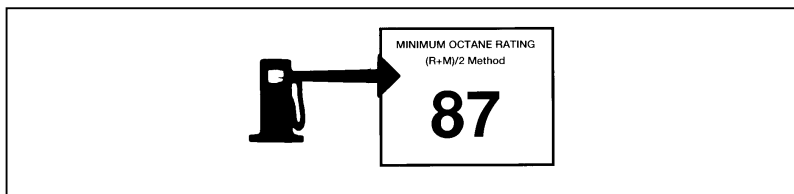

Typical octane rating label

Do not be concerned if your vehicle sometimes knocks lightly. However, if it knocks heavily under most driving conditions on the recommended octane fuel, see your dealer or a qualified service technician to prevent any engine damage.

Fuel Quality

If you are experiencing starting, rough idle or hesitation problems, try a different brand of fuel. If the condition persists, see your dealer or a qualified service technician.

The American Automobile Manufacturers Association (AAMA) issued a gasoline specification to provide information on high quality fuels that optimize the performance of your vehicle. We recommend the use of gasolines that meet the AAMA specification if they are available.

It should not be necessary to add any aftermarket products to your fuel tank if you continue to use a high-quality fuel.

Gasolines for clean air

Ford approves the use of gasolines to improve air quality, including reformulated gasolines that contain oxygenates such as a maximum of 10% ethanol or 15% MTBE. There should be no more than 5% methanol with cosolvents and additives to protect the fuel system.

Servicing Your Villager

Safety Information Relating to Automotive Fuels

WARNING

Automotive fuels can cause serious injury or death if misused or mishandled.

- Turn vehicle off when refueling
- Do not smoke when refueling. Fuels are extremely flammable.
- Do not siphon any fuel by mouth.

WARNING

Gasoline or gasoline blended with methanol can cause blindness and possible death when swallowed. If any fuel is swallowed, call a physician or poison control center immediately.

- Avoid breathing vapors while refueling.
- If fuel is splashed on the skin, wash with soap and water.
- If fuel is splashed in the eyes, remove contact lenses (if worn), flush with water for 15 minutes, and seek medical attention.

Gasoline and gasoline blends may contain small amounts of carcinogens, such as benzene. Long-term exposure to unleaded gasoline vapors has caused cancer in laboratory animals.

If you are taking the medication “Antabuse” or other forms of disulfiram for the treatment of alcoholism, vapor or skin contact with a gasoline-methanol blend may cause the same kind of adverse reaction as drinking an alcoholic beverage. In sensitive individuals, serious personal injury or sickness could result. Consult a physician promptly if you experience an adverse reaction.

Running Out of Fuel

NOTE: Avoid running out of fuel because this situation may have an adverse effect on modern powertrain components.

You may need to crank the engine several times before the fuel system starts to pump fuel from the tank to the engine.

Fuel Economy

Fuel economy is an estimate of the efficiency of your vehicle, and can be calculated as Miles Per Gallon (MPG) or Liters Per 100 Kilometers (L/100K).

Do not calculate fuel economy during your vehicle's break-in period. This would not be an accurate estimate of how much fuel your vehicle will normally use.

To calculate fuel economy:

1. Fill the fuel tank completely and record the initial odometer reading.
2. Every time you buy fuel, record the amount (in gallons or liters) purchased.
3. After at least 3-5 tankfuls, fill the fuel tank and record the final odometer reading.
4. Use these equations to calculate your fuel economy:
 - English: $\text{MPG} = (\text{total miles driven}) \div (\text{gallons used})$
 - Metric: $\text{L}/100\text{k} = \text{Multiply the number of liters used by 100 and divide the answer by the number of kilometers travelled.}$

Servicing Your Villager

Comparisons With Environmental Protection Agency (EPA) Fuel Economy Estimates

EPA fuel economy figures are obtained from laboratory tests under simulated road conditions and may not reflect the actual conditions you experience or your style of driving. The EPA fuel economy estimate is not a guarantee that you will achieve the fuel economy shown.

The following decrease fuel economy:

- Lack of regular, scheduled maintenance
- Rapid acceleration and excessive speed
- Driving with your foot on the brake
- Sudden stops
- Extended engine idling
- Using speed control in hilly terrain
- Extended use of the A/C, defroster, rear window defroster and other accessories
- Underinflated tires
- Heavy loads
- Aftermarket add-ons such as bike, ski or luggage racks, bug deflectors, etc.

Engine Oil Recommendations

We recommend using Motorcraft oil or an equivalent oil meeting Ford Specification WSS-M2C153-F and displaying the American Petroleum Institute **CERTIFICATION MARK** on the front of the container.



The API Certification Mark

Never **use**:

- “Non-Detergent” oils
- Oils labeled API SA, SB, SC, SD, SE, SF or SG
- Additional engine oil additives, oil treatments or engine treatments

Engine oils with an SAE 5W-30 viscosity are **PREFERRED** for your vehicle. They provide the best engine performance, fuel economy and engine protection for all climates down to -15°F (-25°C).

Servicing Your Villager

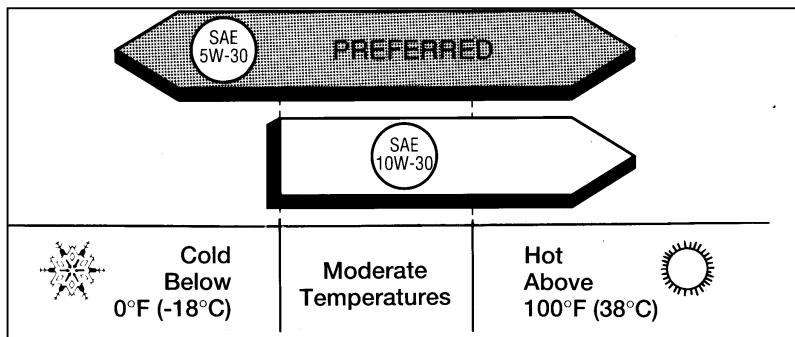

Selecting the right viscosity for your climate

Synthetic engine oils which are CERTIFIED and of the preferred viscosity may be used in your engine. The engine oil and oil filter must still be changed according to the maintenance schedule.

Checking and Adding Engine Oil

Since the proper amount of engine oil is important for safe engine operation, check the oil using the dipstick each time you put fuel in your vehicle. Remember the engine must be off, the oil must be warm and the vehicle must be parked on level ground.

Checking the engine oil level:

1. Turn the engine off after it has warmed up and allow a few minutes for the engine oil to drain back into the oil pan.
2. Set the parking brake fully and make sure that the gearshift is securely latched in P (Park).
3. Open the hood. Protect yourself from engine heat.
4. Locate the engine oil dipstick (highlighted in yellow) and carefully pull it out of the engine.

-
5. Wipe the dipstick clean and put it back into position, making sure it is fully seated.

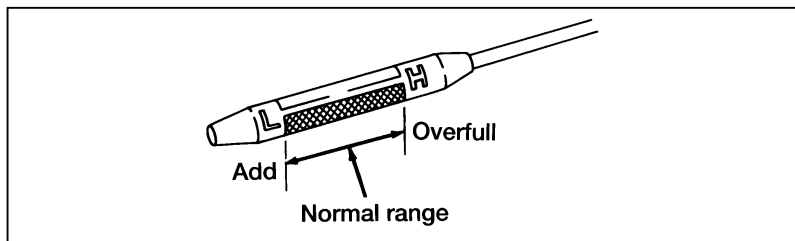

Engine oil dipstick

6. Carefully pull the dipstick out again. If the oil level is below the “L” line, add engine oil as necessary. If the oil level is beyond the letter “H,” engine damage or high oil consumption may occur and some oil must be removed from the engine.
7. Put the dipstick back in and make sure it is fully seated.

Adding engine oil

It may be necessary to add some oil between oil changes. Make sure you use a CERTIFIED engine oil of the preferred viscosity. Your vehicle’s warranty coverage may not apply if engine damage is caused by the use of improper engine oil.

Add engine oil through the oil filler cap highlighted in yellow. To add oil, remove the filler cap and use a funnel to pour oil into the opening. Be careful not to overfill the engine. Recheck the oil level after you finish adding oil.

Servicing Your Villager

Changing the Engine Oil and the Oil Filter

Refer to the *Maintenance Schedule and Record* booklet for recommended intervals.

Follow these directions to change the engine oil and oil filter:

1. Turn the engine off after it has warmed up.
2. Protect yourself from engine heat and the engine oil being drained.
3. Remove the oil pan drain plug(s) and **oil filter**.
4. Drain the oil into a container until flow from the drain plug hole(s) and the filter mounting area slows to a drip.
5. Install the drain plug(s) and a new engine oil filter according to directions on the package.

NOTE: See *Refill Capacities, Motorcraft Parts and Lubrication Specifications* in this chapter for the appropriate oil filter and engine oil refill quantity.

6. Remove the engine oil dipstick (highlighted in yellow) to prevent oil contamination of the engine ventilating system while refilling.
7. Refill the engine with a CERTIFIED engine oil of the preferred viscosity. Start the engine and check for leaks. Follow directions in *Checking and adding engine oil* to be sure the engine is filled to the proper level.

WARNING
Continuous contact with USED motor oil has caused cancer in laboratory mice.

Protect your skin by washing with soap and water.

Engine Coolant

Checking the Engine Coolant

NOTE: Be sure to read and understand *Precautions When Servicing Your Vehicle* at the beginning of this chapter.

Your vehicle's engine coolant protects the engine from overheating in the summer and from freezing in the winter. Check the level of the engine coolant at least once a month, but preferably each time you stop for fuel. Simply check the coolant reservoir, located in the engine compartment. The coolant should stay between the MIN and MAX marks. It will be closer to MAX when the engine is warm and closer to MIN when the engine is cold. To locate the coolant reservoir, see the diagram of your vehicle's engine under *Engine Compartment* in this chapter.

Servicing Your Villager

Adding Engine Coolant

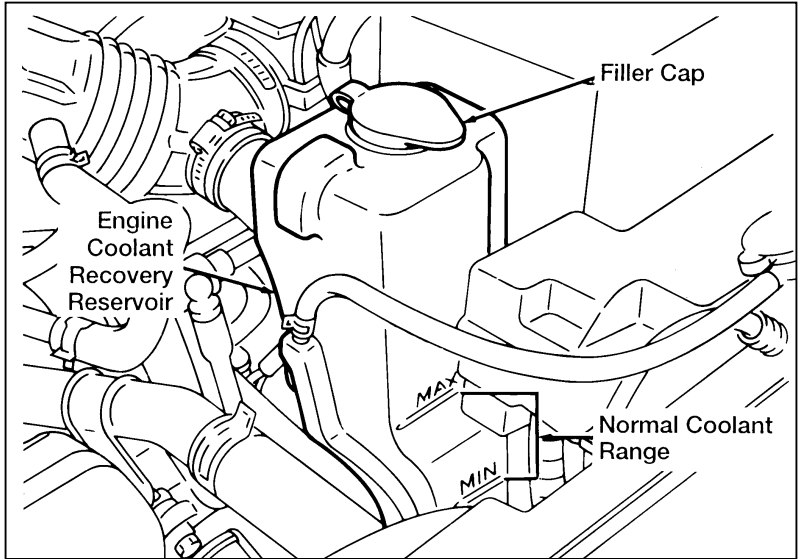

Engine coolant recovery reservoir

WARNING

Do not put engine coolant in the container for the windshield washer fluid.

When the engine is cool, add a 50/50 mixture of engine coolant and water to the engine coolant recovery reservoir — **DO NOT ADD DIRECTLY TO THE RADIATOR.** Add straight water only in an emergency, but you should replace it with a 50/50 mixture of coolant and distilled water as soon as possible.

Check the coolant level in the coolant recovery reservoir the next few times you drive the vehicle. If necessary, add enough of a 50/50 mixture of coolant and water to bring the liquid level to the fill line on the reservoir.

WARNING

Never remove the coolant recovery cap while the engine is running or hot.
--

If you must remove the coolant recovery cap, follow these steps to avoid personal injury caused by escaping steam or engine coolant:

1. Before you remove the cap, turn the engine off and let it cool.
2. When the engine is cool, wrap a thick cloth around the cap and turn it slowly, counterclockwise to the first stop.
3. Step back while the pressure releases.
4. When you are sure that all the pressure has been released, use the cloth to press the cap down, turn it counterclockwise, and remove it.

Use Ford Premium Engine Coolant E2FZ-19549-AA (in Canada, Motorcraft CXC-8-B) or an equivalent premium engine coolant that meets Ford Specification ESE-M97B44-A. Ford Premium Engine Coolant is an optimized formula that will protect all metals and rubber elastomers used in Ford cooling systems for 4 years or 50,000 miles (80,000 km).

Do not use alcohol or methanol antifreeze or any engine coolants mixed with alcohol or methanol antifreeze. Do not use supplemental coolant additives in your vehicle. These additives may harm your engine cooling system. ***The use of an improper coolant may void the warranty of your vehicle's engine cooling system.***

Service Your Villager

Recycled engine coolant

Ford Motor Company recommends that Ford and Lincoln-Mercury dealers use recycled engine coolant produced by Ford-approved processes. Not all coolant recycling processes produce coolant which meets Ford specification ESE-M97B44-A, and use of such coolant may harm engine and cooling system components.

Always dispose of used automotive fluids in a responsible manner. Follow your community's regulations and standards for recycling and disposing of automotive fluids.

Coolant refill capacity

To find out how much fluid your vehicle's cooling system can hold, see *Refill capacities for fluids* in the Index.

Have your dealer check the engine cooling system for leaks if you have to add more than a quart (liter) of engine coolant per month.

Severe winter climate

If you drive in extremely cold climates (less than -34°F [-36°C]), it may be necessary to increase the coolant concentration above 50%. Refer to the chart on the coolant container to ensure the coolant concentration in your vehicle is such that the coolant will not freeze at the temperature level in which you drive during winter months. Never increase the engine coolant concentration above 60%. Leave a 50/50 mixture of engine coolant and water in your vehicle year-round in non-extreme climates.

Checking hoses

Inspect all engine and heater system hoses for deterioration, leaks and loose clamps before adding or replacing engine coolant. Make whatever repairs or replacements are necessary using Motorcraft parts or their equivalents.

Engine Coolant Drain and Flush

To have your engine coolant drained, see your Ford dealer or refer to the procedure in the Service Manual.

Air Filter

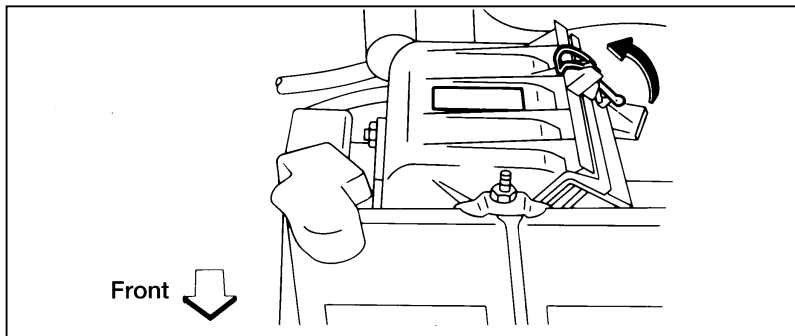

Air filter housing

The air filter should not be cleaned and reused. Replace it according to the maintenance intervals shown in the *Maintenance Schedule and Record* booklet. When replacing the filter, unclip the four clamps and remove the filter. Wipe the inside of the air filter housing with a damp cloth when replacing the filter.

WARNING

Never pour fuel in the throttle body or attempt to start the engine with the air cleaner removed. Doing so could result in fire and personal injury.

Servicing Your Villager

Windshield Washer Fluid and Wipers

Washer Fluid

Check the level of the windshield washer fluid every time you stop for fuel, or when the warning light indicates low washer fluid. The reservoir for washer fluid is located in the engine compartment. This reservoir contains the fluid for both the windshield and liftgate washers.

WARNING

Do not put windshield washer fluid in the container for the engine coolant.
--

If sprayed to clean the glass, engine coolant or antifreeze could make it difficult to see through the windshield.

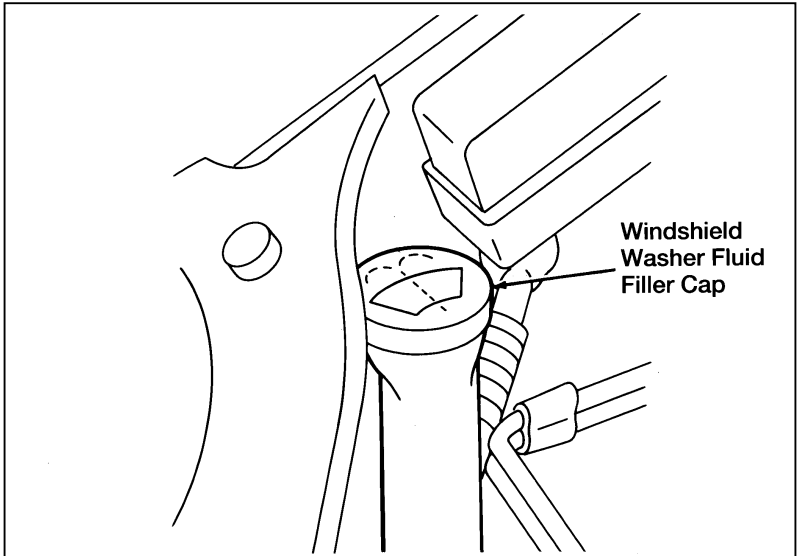

Windshield washer fluid reservoir

Use specially formulated windshield washer fluid rather than plain water, because specially formulated washer fluids contain additives that dissolve road grime. For safety reasons, washer fluids containing an appropriate antifreeze such as methanol should be used in freezing weather (temperatures below 32°F [0°C]). State or local regulations on Volatile Organic Compounds (VOC's) may restrict use of the most common antifreeze, methanol. Washer fluids containing non-methanol antifreeze agents should be used only if they provide cold weather protection without damaging the vehicle's paint finish, wiper blades, and windshield washer system.

Wiper Blades

Check the windshield wiper blades at least twice a year. Also check them whenever they seem less effective than usual. Substances such as tree sap and some hot wax treatments used by commercial car washes reduce the effectiveness of wiper blades.

If the blades do not wipe properly, clean both the windshield and the wiper blades. Use undiluted windshield washer solution or a mild detergent. Rinse thoroughly with clear water. Do not use fuel, kerosene, paint thinner, or other solvents to clean your wiper blades. These will damage your blades.

To reach the wiper blades easily, turn the ignition switch to ACCESSORY and turn your wipers on. Wait for them to reach a vertical position and turn the ignition to OFF. Moving the wipers manually may damage them.

Servicing Your Villager

Wiper blade replacement

If the wipers still do not work properly after you clean them, you may need to replace the wiper blade assembly. When replacing the wiper blade assembly always use a Motorcraft part or equivalent.

To replace the wiper blades:

1. Pull the wiper arm away from the windshield and into the lock position.
2. Turn the blade at an angle from the wiper arm. Push the lock pin to release the blade and pull the wiper blade down toward the windshield to remove it from the arm.
3. Attach a new wiper blade to the wiper arm and press it into place until you hear it click.

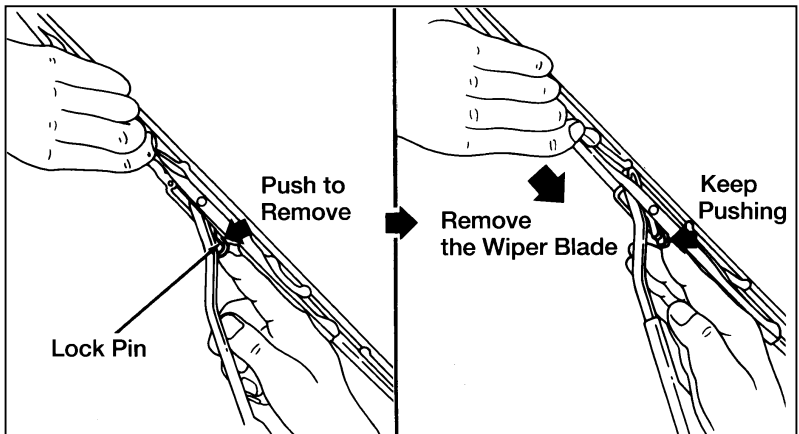

Replacing the wiper blades

Tires

Look at your tires each time you fill your fuel tank. If one tire looks lower than the others, check the pressure in all of them. Always follow these precautions:

- Keep your tires inflated to the recommended pressures.
- Stay within the recommended load limits. See *Driving with a heavy load* in the Index.
- Make sure the weight of your load is evenly distributed.
- Drive at safe speeds.

If you do not take these precautions, your tires may fail or go flat.

WARNING
<p>Always obey posted speed limits. If you drive too fast for road conditions, you could lose control of your vehicle. Under some circumstances, driving at very high speeds for extended periods of time may damage vehicle components, creating a risk of component failure and a potential loss of vehicle control. Any time you lose control of your vehicle, it may result in injury.</p>

At least once a month, check the pressure in all your vehicle's tires, including the spare. Use an accurate tire pressure gauge. Check the tire pressure when tires are cold, after the vehicle has been parked for at least one hour or has been driven less than 3 miles (5 km). You can find the proper cold tire pressure on the Tire Pressure Decal, located in the glove compartment.

WARNING
<p>Improperly inflated tires can affect vehicle handling and can fail suddenly, possibly resulting in loss of vehicle control.</p>

Servicing Your Villager

Tire Inspection and Maintenance

Inspect the tire treads, and remove stones, nails, glass or other objects that may be wedged in the tread grooves. Check for holes or cuts that may permit air to leak from the tire, and make the necessary repairs.

Inspect the tire sidewalls for cuts, bruises and other damage. If you suspect internal damage to the tire, have it removed and checked. You may need to repair or replace it.

Tire Rotation

Because your vehicle's front and rear tires perform different jobs, they often wear differently. To make sure your tires wear evenly and last longer, rotate them at the mileage shown in the *Maintenance Schedule and Record* booklet which came with your vehicle.

In situations where the tires differ from front to rear (snow/traction), simply rotate using a side to side pattern.

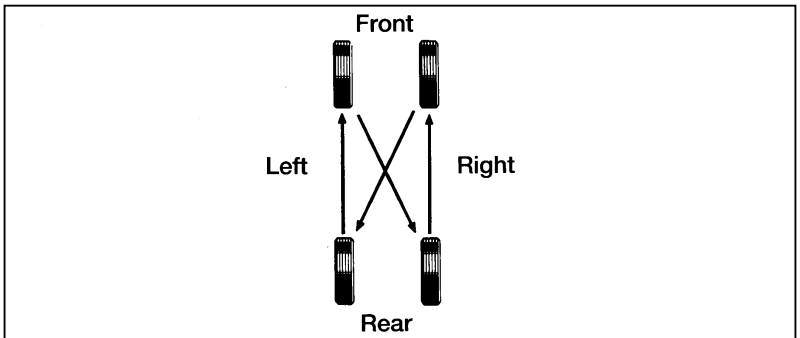

Rotating the tires

After each rotation, adjust individual tire pressure as specified on the Tire Pressure Decal. Tighten wheel lug nuts to the required torque specification and retighten again after 500 miles (800 km).

If your vehicle has the optional full-size spare tire, you may rotate the spare tire into the rotation pattern.

WARNING

If you use the temporary spare tire continuously or do not follow these precautions, the tire could fail, causing you to lose control of the vehicle.

If your vehicle has aluminum wheels, you may remove the spare tire from the wheel and remount it on an aluminum wheel to rotate the spare tire into your vehicle's rotation pattern.

Replacing the Tires

Replace tires that show wear bands. When your tire shows a wear band, it has only 1/16 of an inch (1.59 mm) of tread left.

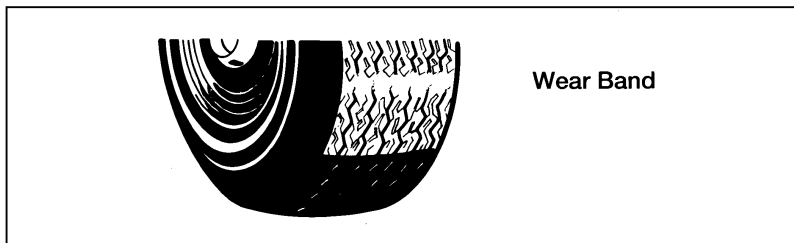

A worn-out tire

Because your vehicle's tires may wear unevenly, you may need to replace them before a wear band appears across the entire tread. Some spots wear more heavily than others.

Servicing Your Villager

Your wheels and tires are match-mounted for improved ride. Before you begin to repair a tire, mark the wheel and tire so that they are properly aligned when remounted. This will ensure that the tires will continue to give you the same ride level.

WARNING

When replacing full size tires, never mix radial, bias-belted, or bias-type tires. Use only the tire sizes that are listed on the tire pressure decal. Make sure that all tires are the same size, speed rating, and load-carrying capacity. Use only the tire combinations recommended on the decal. If you do not follow these precautions, your vehicle may not drive properly and safely.

WARNING

Make sure that all replacement tires are of the same size, type, load-carrying capacity, and tread design (e.g. "All Terrain", etc.), as originally offered by Ford.

WARNING

Failure to follow these precautions may adversely affect the handling of the vehicle and make it easier to lose control and roll over.

Tires that are larger or smaller than your vehicle's original tires may affect the accuracy of your speedometer and odometer.

Wheel and Tire Matching

See an authorized tire dealer for proper servicing procedures. Wheels and tires must be properly removed, matched and remounted to maintain the best possible ride.

Information About Tire Quality Grades

New vehicles are fitted with tires that have their Tire Quality Grade (described below) molded into the tire's sidewall. These Tire Quality Grades are determined by standards that the United States Department of Transportation has set.

Tire Quality Grades apply to new pneumatic tires for use on this vehicle. They do not apply to deep tread, winter-type snow tires, space-saver or temporary use spare tires, tires with nominal rim diameters of 10 to 12 inches (254-305 mm) or limited production tires as defined in Title 49 Code of Federal Regulations Part 575.104(c)(2).

U.S. Department of Transportation — Tire quality grades: **The U.S. Department of Transportation requires Ford to give you the following information about tire grades exactly as the government has written it.**

Treadwear

The treadwear grade is a comparative rating based on the wear rate of the tire when tested under controlled conditions on a specified government test course. For example, a tire graded 150 would wear one and one-half (1 1/2) times as well on the government course as a tire graded 100. The relative performance of tires depends upon the actual conditions of their use, however, and may depart significantly from the norm due to variations in driving habits, service practices and differences in road characteristics and climate.

Traction A B C

The traction grades, from highest to lowest, are A, B, and C, and they represent the tire's ability to stop on wet pavement as measured under controlled conditions on specified government test surfaces of asphalt and concrete. A tire marked C may have poor traction performance.

Servicing Your Villager

WARNING

The traction grade assigned to this tire is based on braking (straight ahead) traction tests and does not include cornering (turning) traction.
--

Temperature A B C

The temperature grades are A (the highest), B, and C, representing the tire's resistance to the generation of heat and its ability to dissipate heat when tested under controlled conditions on a specified indoor laboratory test wheel. Sustained high temperature can cause the material of the tire to degenerate and reduce tire life, and excessive temperature can lead to sudden tire failure. The grade C corresponds to a level of performance which all passenger car tires must meet under the Federal Motor Vehicle Safety Standard No. 109. Grades B and A represent higher levels of performance on the laboratory test wheel than the minimum required by law.

WARNING

The temperature grade for this tire is established for a tire that is properly inflated and not overloaded.
--

WARNING

Excessive speed, underinflation, or excessive loading can cause heat buildup and possible tire failure.
--

The information on braking performance and tire quality grading found in the "Ford Motor Company Passenger Car Consumer Information" pamphlet (FPS 12024-92) also applies to the Villager. This publication is available from your dealer.

Snow Tires and Chains

The tires on your vehicle have all-weather treads that provide traction in rain or snow. However, during the winter months in some climates, you may need to use snow tires and occasionally chains for your tires.

WARNING

When using snow tires, make sure they are the same size and grade as the tires you normally use on your vehicle.

Do not use chains when using a temporary spare. For full size tires, use chains on the tires only in an emergency or if the law requires them where you live. When you use the tire chains:

- Make sure the chains are the right size for your tires. Use only SAE Class “S” chains. Other types may damage your vehicle.
- Put chains on tightly with the ends held down securely. Follow the chain manufacturer’s instructions.
- Drive slowly. If you can hear the chains rub or bang against your vehicle, stop the vehicle and tighten the chains. If you continue to hear the chains rub or bang against your vehicle, remove the chains to prevent damage to your vehicle.
- Avoid fully loading your vehicle if possible.
- Remove tire chains at the first opportunity after using them on snow and ice. Do not use the chains on dry roads.

Make sure your suspension insulators and bumpers are not missing or worn to avoid damage to your vehicle.

Servicing Your Villager

Cleaning the Wheels

Wash the wheels with the same detergent you use to wash your vehicle's body. Do not use acid-based wheel cleaners, steel wool, abrasives, fuel, or strong detergents. These substances will damage protective coatings. Use tar and road oil remover to remove grease and tar.

If you have whitewall tires that are difficult to clean with regular detergent, use whitewall tire cleaner. Follow the directions on the container and rinse the tires with plenty of clean water.

NOTE: Before going to a car wash, find out if the brushes are abrasive.

Battery

The Motorcraft low-maintenance battery requires periodic service as detailed below. The low-maintenance battery has removable vent caps for checking the electrolyte level and for adding water, if needed. For longer, trouble-free operation, keep the top of the battery clean and dry. Also, make certain the battery cables are tightly fastened to the battery terminals.

If you see any corrosion on the battery cables or terminals, remove the cables from the terminal and clean them both with a wire brush. You can neutralize the acid with a solution of baking soda and water. Reinstall the cables when you are done cleaning them, and apply a small quantity of grease to the top of each battery terminal to help prevent corrosion.

Battery replacement

If your original equipment battery requires replacement while under warranty, it may be replaced by a Motorcraft low-maintenance battery. The low-maintenance battery has removable vent caps for checking the electrolyte level and for adding water, if needed.

Check the electrolyte level of each cell (there are six) at least every 12 months or 12,000 miles (20,000 km). Keep the electrolyte level between the MAX and MIN lines that are on the side of the battery (you will have to remove the battery cover to see the fill lines on the battery). Do not overfill the battery cells. When operating at ambient temperatures above 90°F (32°C), check the electrolyte level more frequently.

If the level of the electrolyte in a cell of the battery is low, add distilled water until the proper level in each cell is restored. Plain tap water will work; but if it is “hard water” having a high mineral or alkali content, the life of the battery may be reduced and the frequency of maintenance required on the battery will increase.

Help Us Protect Our Environment

Ford Motor Company strongly recommends that used lead-acid batteries be returned to an authorized recycling facility for disposal.

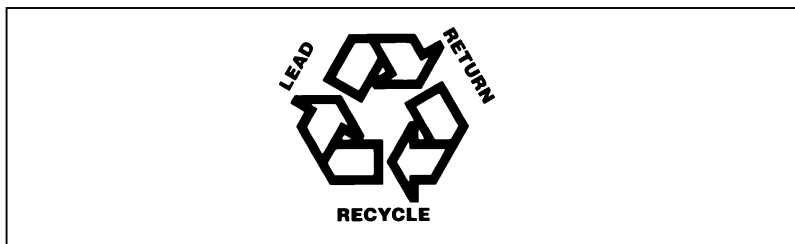

Battery recycling symbol

WARNING
The gases around the battery can explode if exposed to flames, sparks, or lit cigarettes. An explosion could result in injury or vehicle damage.

Servicing Your Villager

WARNING

To protect yourself when charging a battery, always shield your face and eyes. Make sure that you can breathe fresh air.

WARNING

Batteries contain sulfuric acid which burns skin, eyes, and clothing.
--

If the acid touches someone's skin, eyes, or clothing, immediately flush the area with water for at least 15 minutes. If someone swallows the acid, have him or her drink lots of milk or water first, then Milk of Magnesia, a beaten egg, or vegetable oil. Call a doctor immediately.

WARNING

Applying too much pressure on the ends when lifting a battery could cause acid to spill. Lift the battery with a carrier or with your hands on the opposite corners.

Automatic Transaxle Fluid

Under normal circumstances, you do not need to check the fluid level of the transaxle since your vehicle does not use up transaxle fluid. However, if the transaxle is not working properly, (for example, slipping or shifting slowly), or you notice some sign of fluid leakage, the fluid level should be checked.

It is best to check the transaxle fluid level at normal operating temperature, after approximately 20 miles (30 km) of driving. However, if necessary, you can check the fluid level without having to drive 20 miles (30 km) to obtain a normal operating temperature if outside temperatures are above 50°F (10°C).

NOTE: If the vehicle has been operated for an extended period at high speeds or in city traffic during hot weather, or if it has been pulling a trailer, the engine should be turned off for about 30 minutes to allow the fluid to cool before checking.

Checking the Automatic Transaxle Fluid

With the vehicle on a level surface, start the engine and move the gearshift lever through all of the gear ranges allowing sufficient time for each position to engage. Securely latch the gearshift lever in the P (Park) position, fully set the parking brake and leave the engine running.

Wipe off the dipstick cap, pull the dipstick out and wipe the indicator end clean. Put the dipstick back into the filler tube and make sure it is fully seated. Pull the dipstick out and read the fluid level.

When checking fluid at normal operating temperature, the fluid level should be within the crosshatched area on the dipstick. When the vehicle has not been driven, and outside temperature is above 50°F (10°C), the fluid level should be between the notches on the dipstick.

WARNING
Your vehicle should not be driven if the transaxle fluid level is below the bottom notch on the dipstick.

Servicing Your Villager

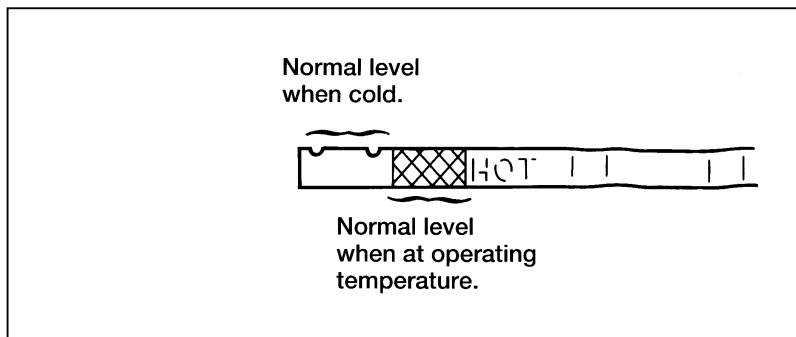

Automatic transaxle fluid dipstick

Adding Automatic Transaxle Fluid

The fluid type is stamped on the dipstick. Before adding any fluid, be sure that the correct type will be used.

Add fluid in 1/2 pint (0.25 liter) increments through the filler tube to bring the level to the correct area on the dipstick. If an overfill occurs, excess fluid should be removed by a qualified technician.

NOTE: Always dispose of used automotive fluids in a responsible manner. Follow your community's standards for disposing of these types of fluids. Call your local recycling center to find out about recycling automotive fluids.

NOTE: Always use Motorcraft MERCON® or equivalent MERCON® automatic transaxle fluid when you refill your automatic transaxle fluid.

Brake Fluid

Your vehicle is equipped with a brake fluid level indicator in the master cylinder which lights the BRAKE warning light on the instrument panel when the brake fluid level is low.

Under normal circumstances, your vehicle should not use up brake fluid rapidly. However, expect the level of the brake fluid to slowly fall as you put more mileage on your vehicle and the brake pads wear.

Check the brake fluid at least once a year. You can do this by looking at the fluid level in the plastic brake fluid reservoir on the master cylinder. The fluid level should be at or near the MAX mark.

WARNING

Brake fluid is toxic.

If brake fluid contacts eyes, flush eyes with running water for 15 minutes. Get medical attention if irritation persists. If taken internally, drink water and induce vomiting. Get medical attention immediately.

If the fluid is low, carefully clean and remove the filler cap from the reservoir. Fill the reservoir to the MAX line with Ford High Performance DOT 3 Brake Fluid C6AZ-19542-AA or DOT 3 equivalent fluid meeting Ford specification ESA-M6C25-A.

WARNING

If you use a brake fluid that is not DOT 3, you will cause permanent damage to your brakes.
--

Do not fill the reservoir above the MAX line.

If you find that the fluid level is excessively low — below the seam or ridge on the outside of the plastic reservoir — have the brake system inspected.

WARNING

Do not let the reservoir for the master cylinder run dry. This may cause the brakes to fail.

Servicing Your Villager

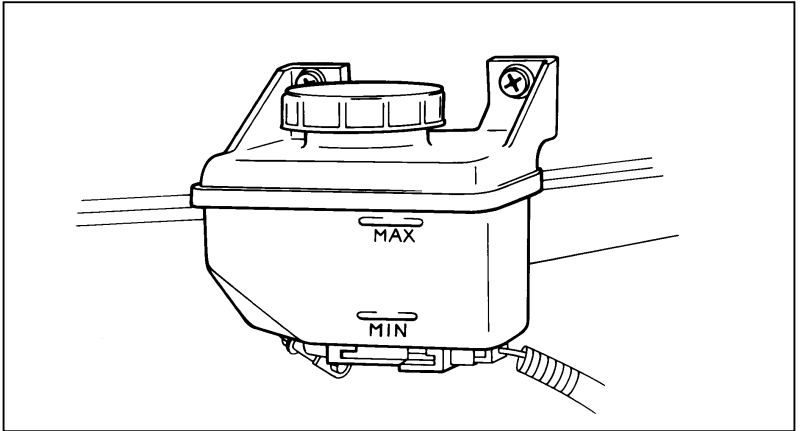

Brake fluid master cylinder reservoir

Power Steering Fluid

Check the level of the power steering fluid at least twice a year (i.e., every Spring and Fall).

Checking and Adding Power Steering Fluid

1. Start the engine and let it run until the power steering fluid reaches normal operating temperature. The power steering fluid will be at the right temperature when the engine coolant temperature gauge in the instrument cluster is near the center of the NORMAL operating temperature range.
2. While the engine idles, turn the steering wheel back and forth several times. Make sure that the cap assembly is installed at this time.
3. Then turn the engine off.
4. Check the fluid level in the power steering fluid reservoir.

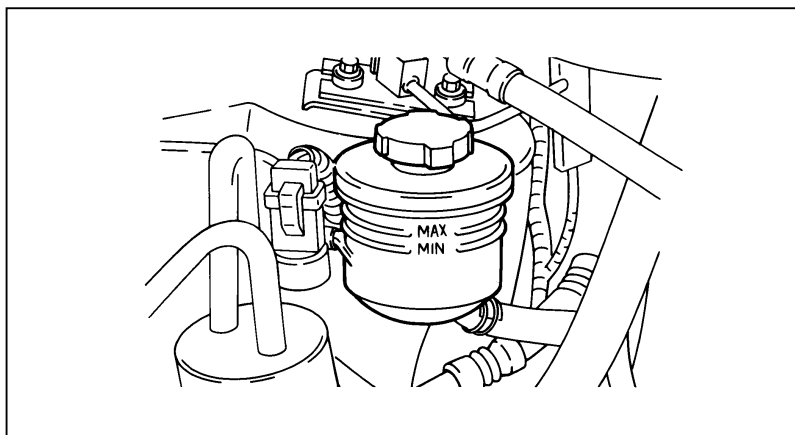

Power steering fluid reservoir

5. If the power steering fluid is low, add fluid in small amounts, continuously checking the level, until the fluid is between the minimum (MIN) and maximum (MAX) lines on the reservoir. Do not overfill. To find out how much fluid your vehicle's reservoir for the power steering fluid will hold, see *Refill Capacities, Motorcraft Parts, and Lubricant Specifications* later in this chapter.

Use only power steering fluid that meets Ford Specification ESW-M2C33-F, such as Ford Premium Power Steering Fluid, E6AZ-19582-AA or an equivalent Type F Automatic Transaxle Fluid with a Ford registration number (an 8-digit number beginning with "2P" printed on the fluid container).

NOTE: If the power steering fluid is low, do not drive your vehicle for a long period of time before adding fluid. This can damage the power steering pump.

Servicing Your Villager

If you must check the power steering fluid when it is cold, make sure that the fluid reaches at least the minimum (MIN) mark. The reading will only be accurate if the fluid temperature is approximately 70° to 100°F (21° to 38°C).

Fuses, Fuse Links and Circuit Breakers

Fuses, fuse links and circuit breakers protect your vehicle's electrical system from overloading. If electrical parts in your vehicle are not working, the system may have been overloaded causing a blown fuse or tripped circuit breaker. Before you replace or repair any electrical parts, check the appropriate fuses or circuit breakers.

The following charts tell you which fuses or circuit breakers protect each electrical part of your vehicle. If a fuse blows or a circuit breaker trips (opens) a circuit, all the parts of your vehicle that use that circuit will not work.

Once you have determined which fuses or circuit breakers to check, follow the procedures under *Checking and replacing fuses* or *Checking and replacing circuit breakers* later in this chapter.

NOTE: Fuse links should only be repaired by your Ford or Lincoln-Mercury dealer.

Checking and Replacing Fuses

If you need to check a fuse, find the fuse panel for the electrical system, which is located under the instrument panel, and follow these steps:

1. To remove the fuse panel cover, pull down on the fuse panel cover handle.

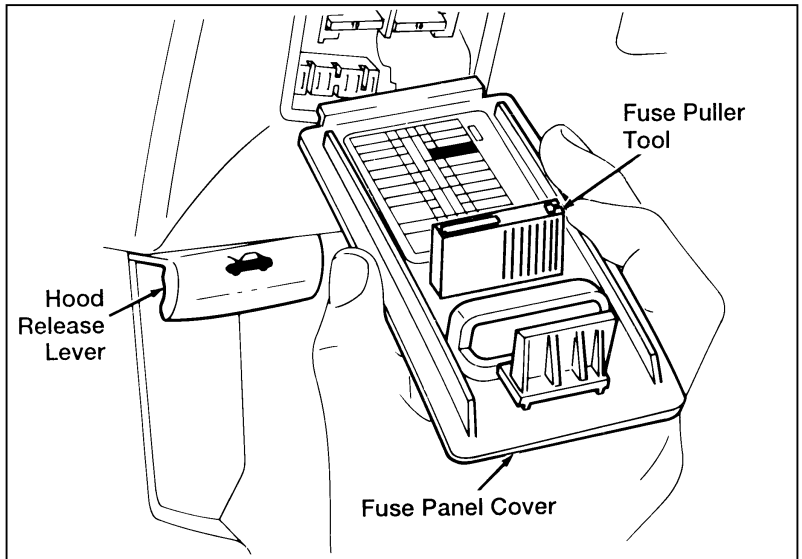

The instrument panel fuse panel

Servicing Your Villager

2. On the fuse panel cover, find the number of the fuse you want to check. The diagram on the cover tells you where to locate the fuse on the panel.

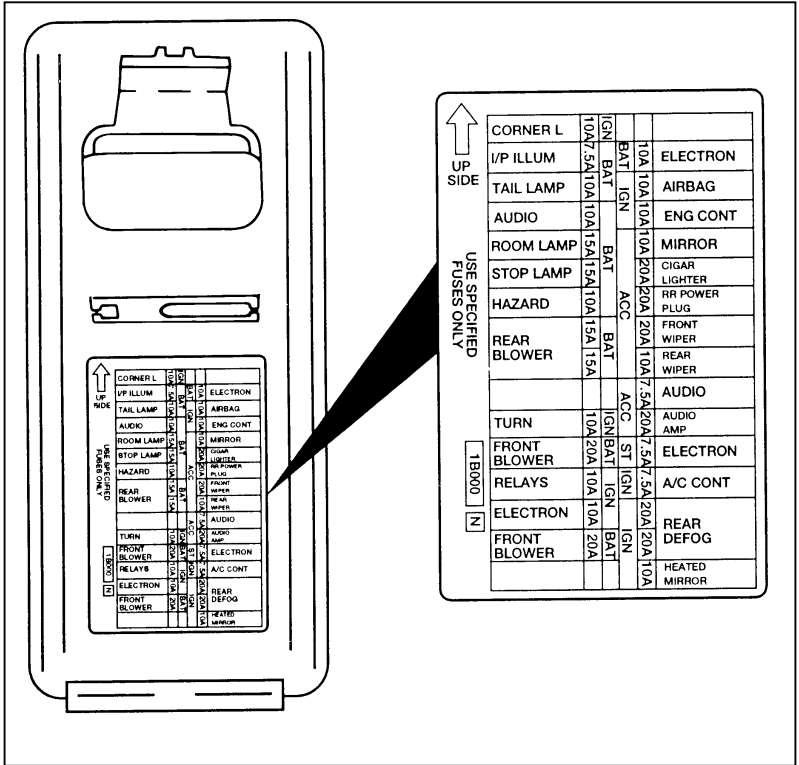

The fuse panel cover

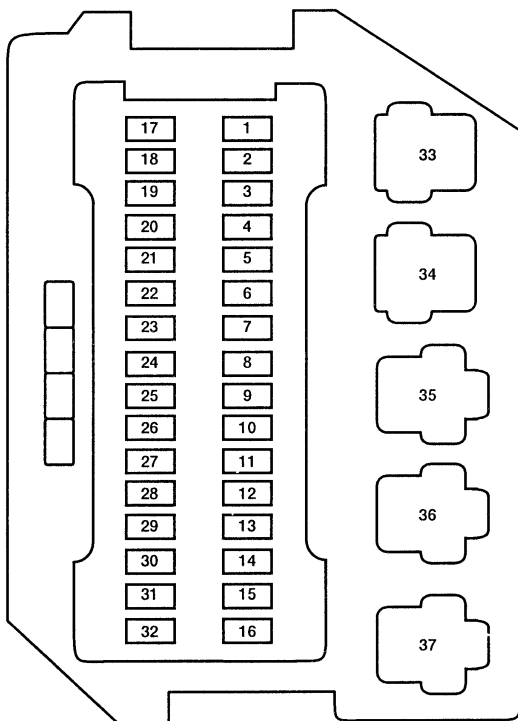

Servicing Your Villager

Fuse/ Relay	Name	Amps	Circuit Protected
1	Open	—	Not Used
2	Electron	10	A/C (Air Conditioning), Timer Module
3	Airbag	10	Air Bag
4	Engine Cont	10	Engine Emissions, Evaporative Emissions, Powertrain Control Module (PCM)
5	Mirror	10	Power Mirror, Timer Module
6	Cigar Lighter	20	Cigar Lighter
7	Rear Power Plug	20	Rear Power Plug
8	Front Wiper	20	Front Windshield Wiper/Washer
9	Rear Wiper	10	Rear Window Wiper/Washer
10	Audio	7.5	Radio, Power Antenna, Rear Integrated Control Panel (RICP)
11	Audio Amp	20	Subwoofer Amplifier
12	Electron	7.5	Powertrain Control Module (PCM)
13	A/C Cont	7.5	A/C, Auto Light, Rear Defrost Switch
14	Rear Defog	20	Rear Defrost
15	Rear Defog	20	Rear Defrost
16	Heated Mirror	20	Heated Power Outside Side View Mirrors
17	Corner L	10	Cornering Lamp
18	I/P Illum	7.5	Instrument Illumination, Radio Illumination
19	Tail Lamp	10	Tail Lamp, Rear Parking Lights
20	Audio	10	CD, Power Antenna, Radio
21	Room Lamp	15	Dome Lamps, Step Lamps, Warning Chime
22	Stop Lamp	15	Shift-Lock Solenoid, Stoplamps
23	Hazard	10	Hazard Flasher
24	Rear Blower	15	Rear Blower Motor

Fuse/Relay	Name	Amps	Circuit Protected
25	Rear Blower	15	Rear Blower Motor
26	Open	—	Not Used
27	Turn	10	Turn Signal Lamps
28	Front Blower	20	Front Blower Motor
29	Relays	10	Relays in Main Fuse Junction Panel
30	Electron	10	Anti-lock Brakes (ABS), Backup Lamps, Overdrive Off Lamp, PRND Switch
31	Front Blower	20	Front Blower Motor
32	Open	—	Not Used
33	Accessory Relay #1	Relay	Fuses 17, 18, 19
34	Ignition Relay	Relay	Fuses 26, 27, 29, 30
35	Accessory Relay #2	Relay	Fuses 5, 6, 7, 8, 9
36	Rear Defrost Relay	Relay	Fuses 14, 15, 16
37	Blower Relay	Relay	Fuses 28, 31

- Check the fuse to see if it is blown. Look through the clear side of the fuse to see if the metal wire inside is separated. If it is, the fuse is blown and should be replaced.

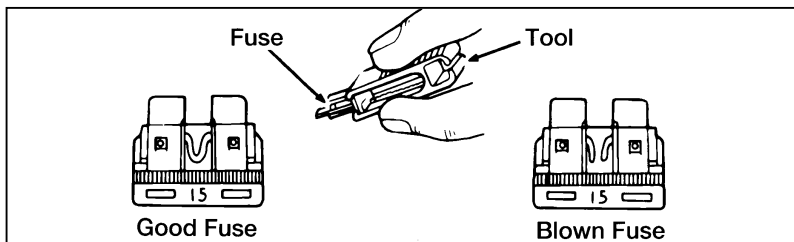

Fuse puller tool and fuse

Servicing Your Villager

4. Use the fuse puller tool to remove the blown fuse and replace the fuse with one that has the right amperage rating (see the fuse panel cover for amperage ratings).

WARNING

Always replace a fuse with one that has the specified amperage rating. Using a fuse with a higher amperage rating can cause severe wire damage and could start a fire.

5. Put the fuse panel cover back on.

Even after you replace a fuse, it will continue to blow if you do not find what caused the overload. If the fuse continues to blow, have your electrical system checked.

The following chart indicates the colors and amperage ratings of standard fuses.

Fuse Rating	Color
10 amp	Red
15 amp	Blue
20 amp	Yellow
30 amp	Light Green
30 amp FL	Pink
40 amp	Green
60 amp FL	Yellow
80 amp FL	Black
100 amp FL	Blue

Engine Compartment Main Fuse Panel

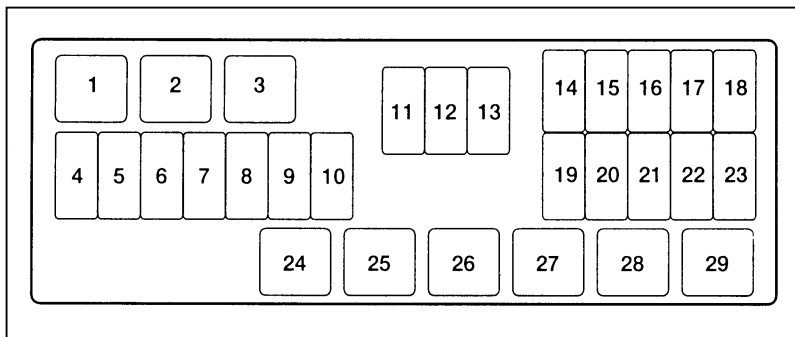

Engine compartment main fuse panel

Servicing Your Villager

Fuse/Relay	Name	Amps	Circuit Protected
1	RAD FAN LO	Relay	Cooling Fan (Low Speed)
2	RAD FAN HI 1	Relay	Cooling Fan (Medium Speed)
3	RAD FAN HI 2	Relay	Cooling Fan (High Speed)
4	POWER WINDOW	30	Power Seat, Power Window, Sun Roof
5	ABS	30	Anti-lock Brake Control Module
6	RAD FAN	65	Cooling Fan
7	FRONT BLOWER	65	Front Blower Motor
8	MAIN	100	Hazard Lamps, Interior Illumination, Radio, Stoplamps, Transmission Control Module
9	ALT	120	Mini Fuse Portion of Main Fuse Junction Panel
10	RR DEF	45	Heated Mirrors, Heated Rear Window, Rear Blower Motor
11	IGN SW	30	Ignition Switch
12	OPEN	—	Not Used
13	OPEN	—	Not Used
14	H/L RH	15	Right-Hand Headlamp
15	H/L LH	15	Left-Hand Headlamp
16	ALT	10	Alternator Input

Fuse/ Relay	Name	Amps	Circuit Protected
17	ENG CONT	10	Powertrain Control Module (PCM) Relay
18	INJ	10	Fuel Injectors
19	FUEL PUMP	15	Fuel Pump Relay
20	HORN	15	Horn Relay
21	ABS	20	Anti-lock Brake Hydraulic Actuator
22	HOOD LAMP	15	Hood Illumination Lamp
23	S.E.C.	7.5	Keyless Entry Beeper, Timer Module
24	HORN	Relay	High Horn, Low Horn
25	FUEL PUMP	Relay	Fuel Pump
26	INHIBIT	Relay	Starter Motor
27	HEADLAMP RH	Relay	Right-Hand Headlamp
28	BULB CHECK	Relay	Brake Warning Lamp, Charge Warning Lamp
29	ASCD HOLD	Relay	Speed Control Module

Circuit Breakers

If you need to check a circuit breaker that is on the fuse panel, see *Fuses, checking and replacing* in the Index to find out how to locate the fuse panel.

Since you need diagnostic equipment to check whether a circuit breaker works and such equipment comes with instructions, we do not discuss how to check circuit breakers. If you have questions about circuit breakers or how to check them, see your Lincoln-Mercury dealer.

However, you should know that the circuit breakers will reset themselves and allow the electrical parts to work again once the overload on the circuit is removed. If the circuit breakers continue to cut off electricity, have your vehicle's electrical system checked.

Servicing Your Villager

If you replace a circuit breaker, use one with the same amperage rating. To remove a circuit breaker mounted by the fuse panel, grip it with your finger and thumb and pull it straight out of its socket.

Relays

Relays are devices which receive signals from components or systems. After receiving signals, relays transfer these signals to activate or deactivate other components or systems. A relay box is located near the windshield washer fluid reservoir.

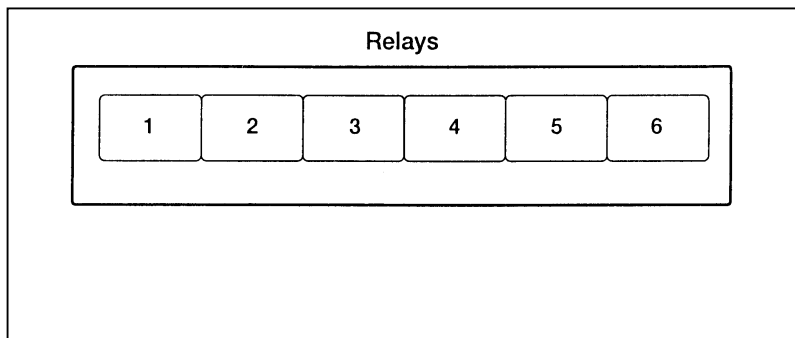

The relay box

Relay Location	Description
1	Antitheft (Interrupt)
2	Headlamp LH
3	Blank
4	FICD
5	Auto Light Headlamp / Antitheft Headlamp
6	Air Conditioner

Lights and Bulb Replacement

It is a good idea to check the operation of the following lights frequently:

- headlamps
- high-mount brakelamp
- tail lamps
- brakelamps
- hazard flasher
- turn signals
- license plate lamp

The alignment of your headlamps should be checked if:

- oncoming motorists frequently signal you to turn off your vehicle's high beams when you do not have the high beams on
- the headlamps do not seem to give you enough light to see clearly at night
- the headlamp beams are not pointed slightly down and to the right

Servicing Your Villager

Headlamp Bulb

The headlamps on your vehicle use replaceable bulbs. When the lamp burns out, simply replace the bulb, rather than the whole lamp.

WARNING
<p>Handle a halogen headlamp bulb carefully and keep out of children's reach. Grasp the bulb only by its plastic base and do not touch the glass. The oil from your hand could cause the bulb to break the next time the headlamps are operated.</p>

Do not remove the burned out bulb unless you can immediately replace it with a new one. If a bulb is removed for an extended period of time, contaminants may enter the headlamp and affect its performance.

Removing the headlamp bulb

1. Make sure that the engine is off and the headlamp switch on the instrument panel is in the OFF position.
2. Remove the electrical connector from the bulb by pulling the connector away from the bulb assembly.

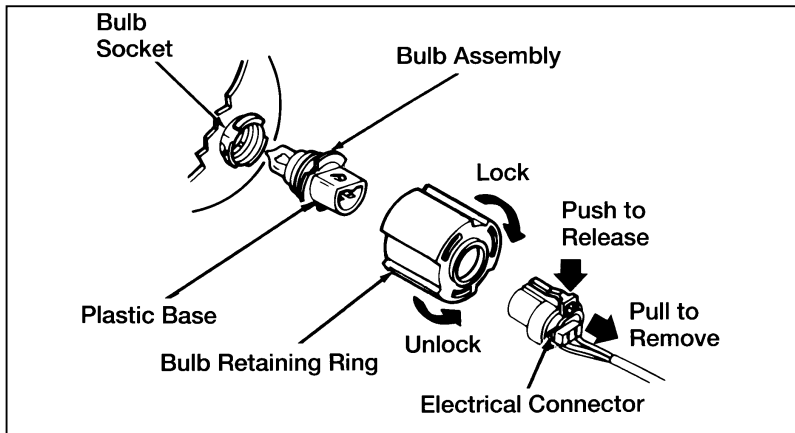

The headlamp bulb assembly

3. Remove the bulb retaining ring by turning it counterclockwise $1/8$ of a turn to free it from the socket. Then slide the ring off the plastic base. Keep the ring. **You must use it again to hold the new bulb in place.**

Servicing Your Villager

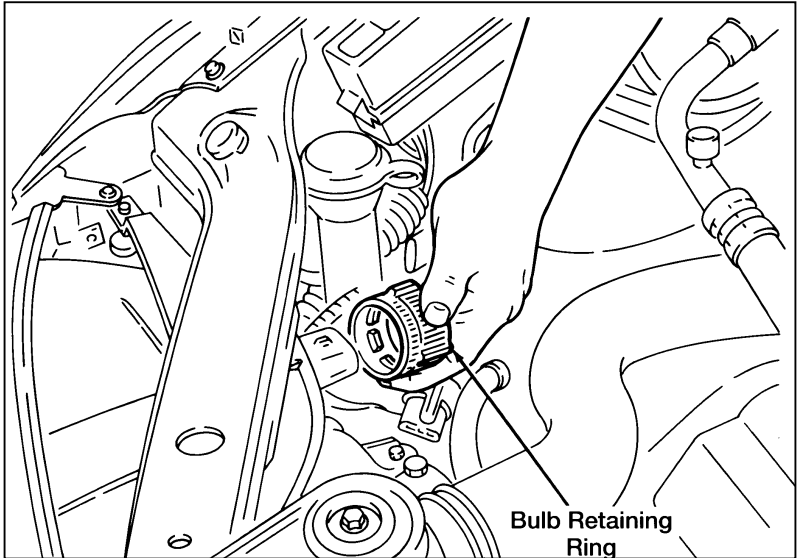

Removing the headlamp bulb retaining ring

4. Carefully remove the bulb assembly from its socket by gently pulling it rearward without turning.
5. Do not touch the bulb with your skin or you could shatter the bulb. Always grasp the bulb assembly from the plastic base.
6. Be sure that you have the proper replacement bulb ready before you discard the burned out bulb.

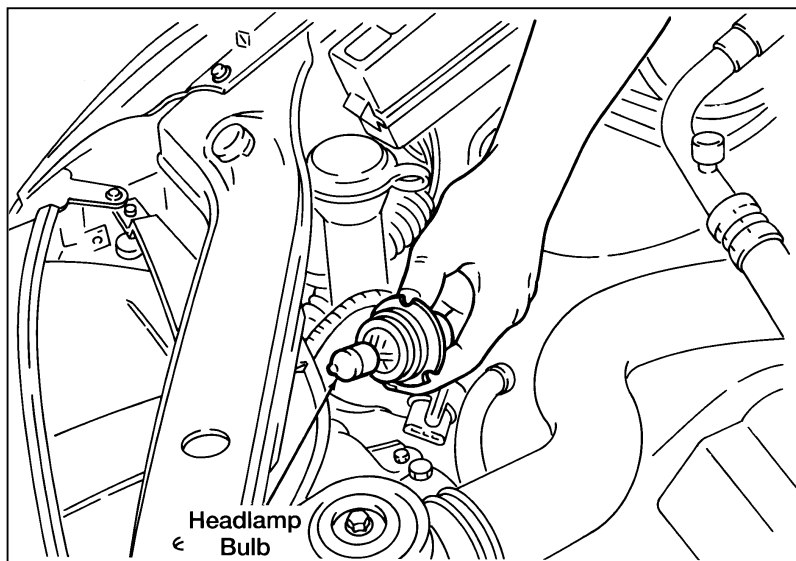

Headlamp bulb replacement

Installing the headlamp bulb

1. With the flat side of the bulb's plastic base facing upward, insert the glass end of the bulb into the socket. You may need to turn the bulb left or right to line up the grooves in the plastic base with the tabs in the socket. When the grooves are aligned, push the bulb into the socket until the plastic base contacts the rear of the socket. Do not touch the glass with your fingers.
2. Slip the retaining ring over the plastic base until it contacts the rear of the socket. Lock the ring into the socket by rotating it until you feel a "stop."
3. Push the electrical connector into the rear of the plastic base until it snaps, locking it into place.

Servicing Your Villager

- Turn the headlamps on and make sure that they work properly. If the headlamp was correctly aligned before you changed bulbs, you should not need to align it again.

Replacing the Bulbs

There are several different types of replacement bulbs for your vehicle. The following illustration indicates the proper method of removal and installation for each bulb.

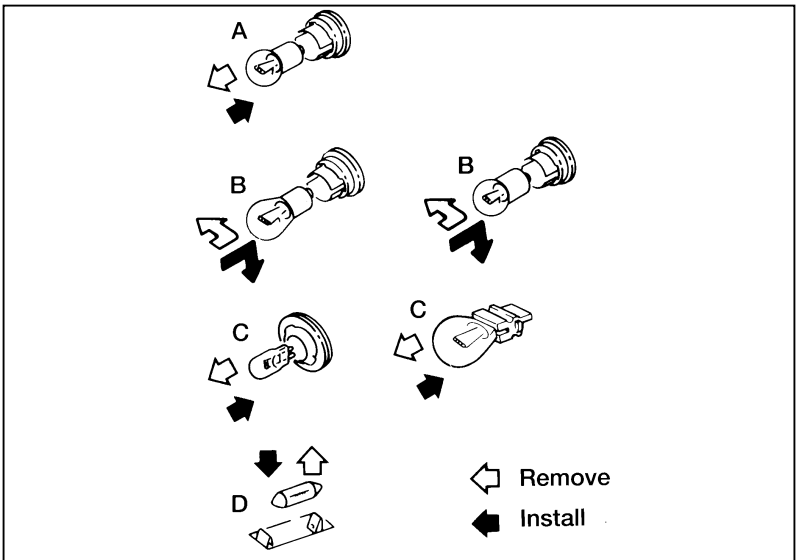

The replacement bulbs

The illustrations in this section will provide you with reference for changing many of the bulbs on your vehicle.

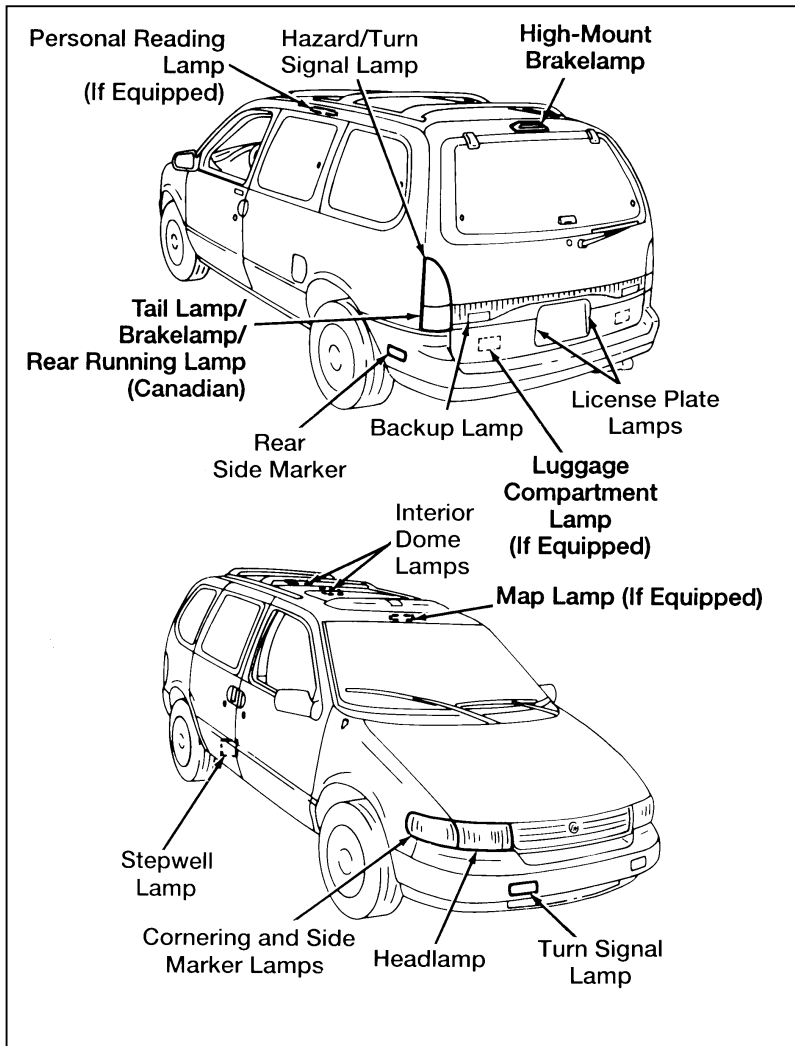

Bulb locations

Servicing Your Villager

Bulb replacement chart

Function	Number of Bulbs	Trade Number
Front park/Turn lamps	2	3157-NA
Headlamps – high & low beam	2	9004
Cornering lamp	2	3157
Front side marker lamp	2	194
Rear license plate lamp	2	194
High-mount brakelamp	1	912
Hazard/Turn signal lamp	2	2057
Brakelamp/Tail lamp/Rear running lamp (Canadian)	2	2057
Backup lamp	2	3156
Liftgate light	1	211-2
Rear side marker lamp	2	194
Overhead dome lamp	2	211-2
Personal reading lamp	1	208
Map lamps	2	—
Underhood lamp	1	912
Stepwell lamp	1	194

High-mount Brakelamp

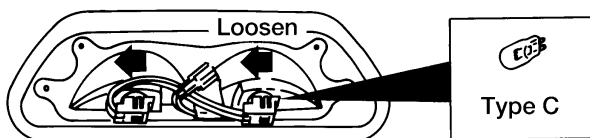
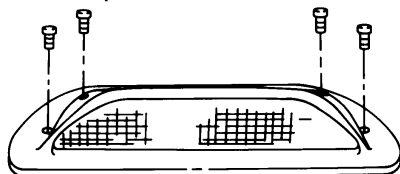

License Plate Lamp

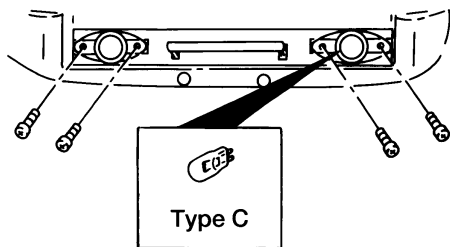

Servicing Your Villager

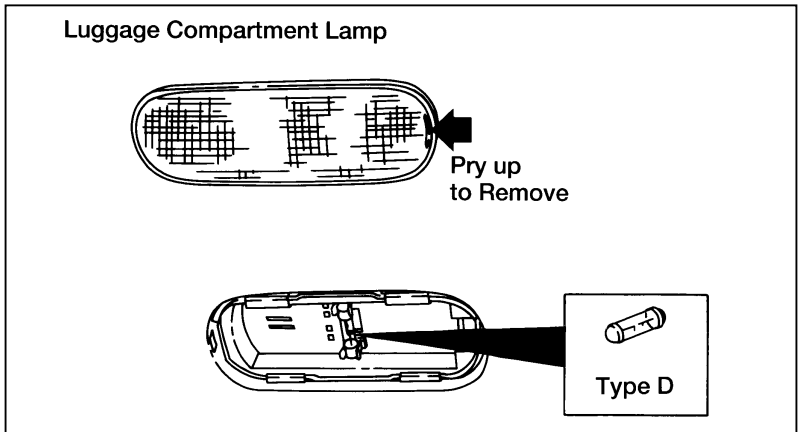
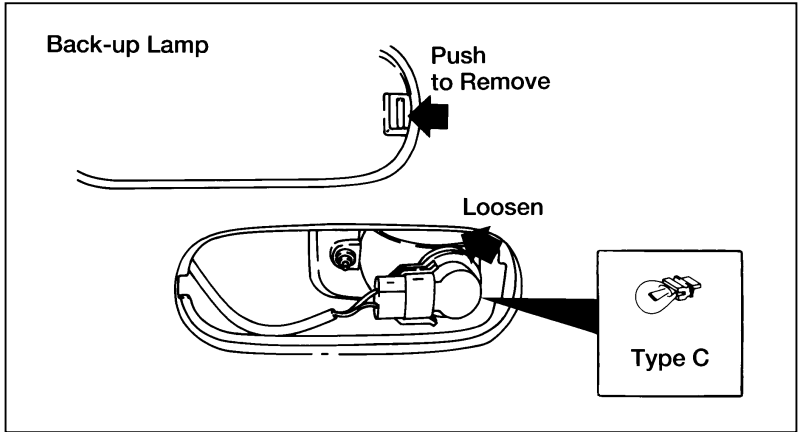

Rear Side Marker Lamp

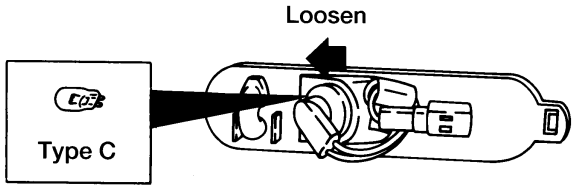
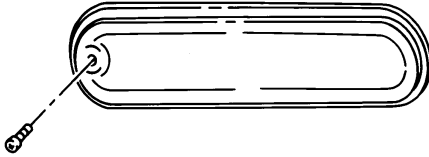

Rear Combination Lamp

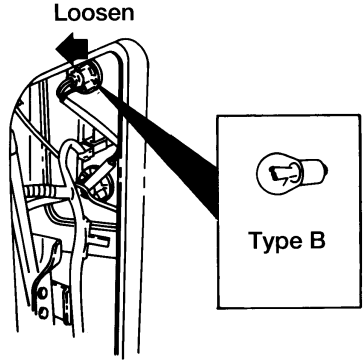

Servicing Your Villager

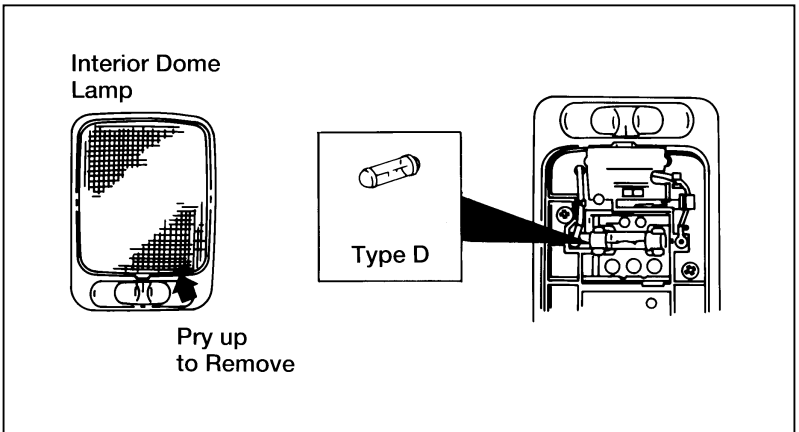
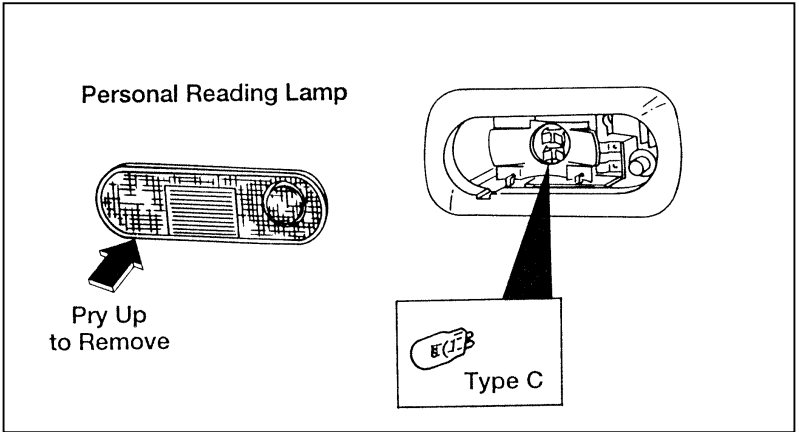

Map Lamps

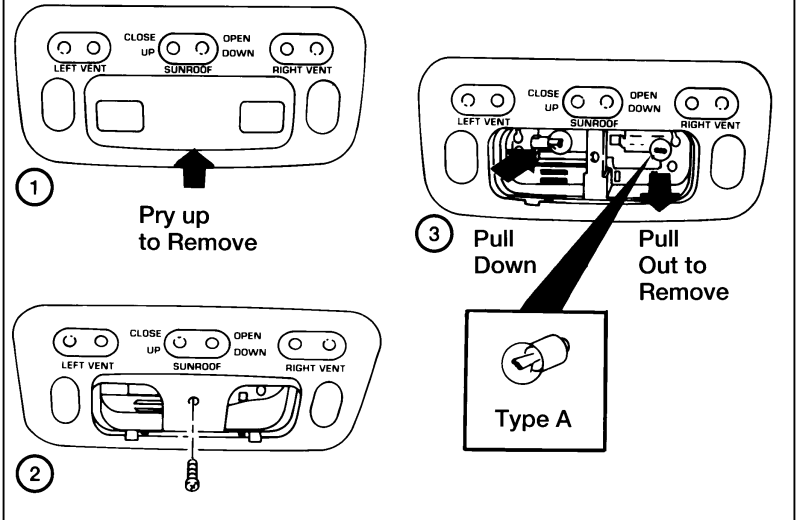

Front Turn Signal Lamp

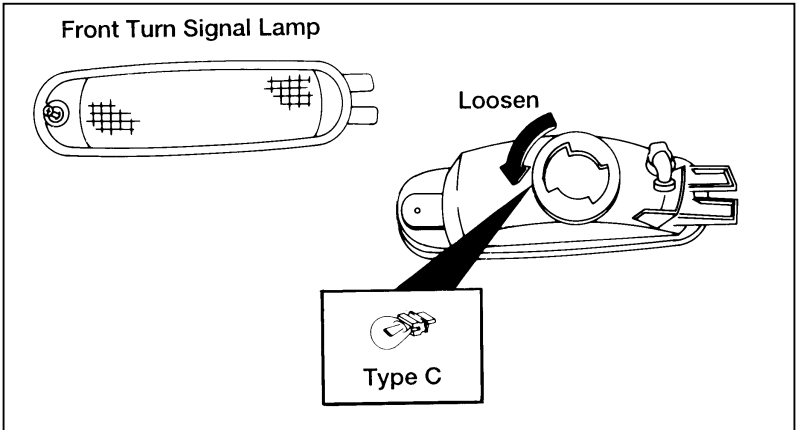

Servicing Your Villager

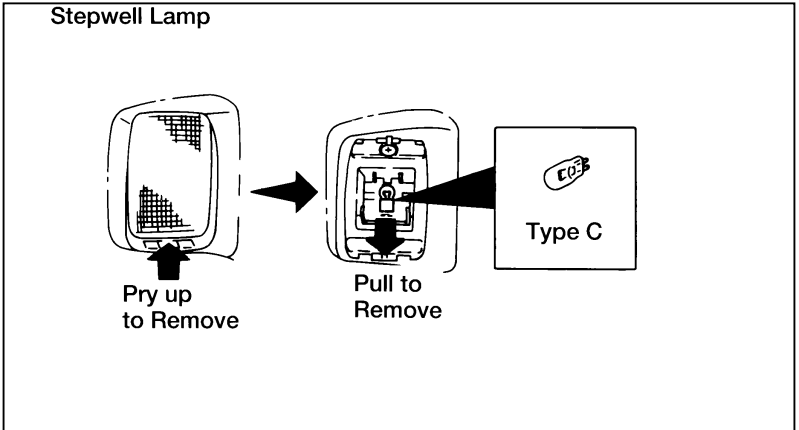
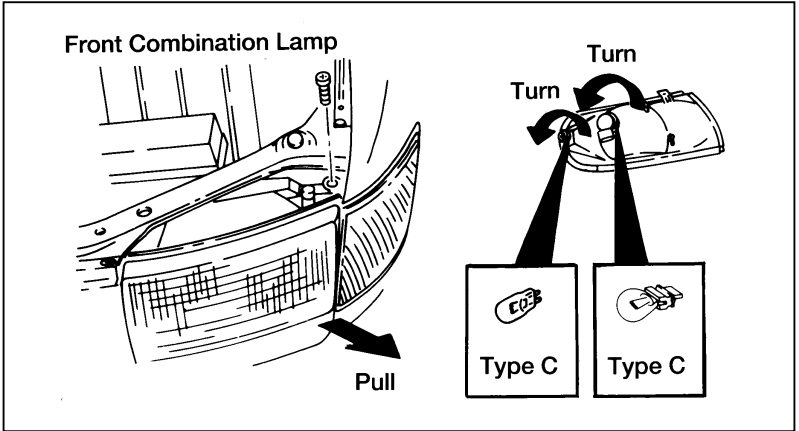

Emission Control System

Your vehicle is equipped with a catalytic converter which enables your vehicle to comply with applicable exhaust emission requirements.

WARNING

Exhaust leaks may result in the entry of harmful and potentially lethal fumes into the passenger compartment. Under extreme conditions excessive exhaust temperatures could damage the fuel system, the interior floor covering, or other vehicle components, possibly causing a fire.

Malfunctions in the engine or exhaust system can result in excessive exhaust system temperatures. Under extreme conditions (for example, towing a trailer up a steep hill on a very hot day with a malfunctioning engine or exhaust system) high exhaust system temperatures could be damaging.

WARNING

Excessive exhaust temperatures could damage the fuel system, the interior floor covering or other vehicle components, possibly causing a fire.

To make sure that the catalytic converter and the other emission control parts continue to work properly:

- Use only unleaded fuel.
- Avoid running out of fuel.
- Never turn off the ignition while your vehicle is moving, especially at high speeds.
- Have the services listed in your *Maintenance Schedule and Record* booklet performed according to the specified schedule.

Servicing Your Villager

WARNING

Do not park, idle, or drive your vehicle in dry grass or other dry ground cover. The emission system heats up the engine compartment and exhaust system, which can start a fire.

WARNING

Do not remove the floor carpet in your vehicle. Emission controls cause high exhaust temperatures under the floor.

Watch for fluid leaks, strange odors, smoke and loss of oil pressure. Also watch for the charge warning light, the check engine light, or the temperature warning light. These sometimes indicate that the emission system is not working properly.

Do not make any unauthorized changes to your vehicle or engine. Changes that cause more unburned fuel to reach the exhaust system can increase the temperature of the engine or exhaust system.

In general, maintenance, replacement, or service of the emission control devices or systems in your new Ford Motor Company vehicle or engine may be performed at your expense by any automotive repair establishment or individual using automotive parts equivalent to those with which your vehicle or engine was originally equipped.

By law, anyone who manufactures, repairs, services, sells, leases vehicles, trades vehicles, or supervises a fleet of vehicles is not permitted to intentionally remove an emission control device or prevent it from working. In some of the United States and in Canada, vehicle owners may be liable if their emission control device is removed or is prevented from working.

Do not drive your vehicle if it does not operate properly. See your dealer if the engine runs on for more than five seconds after you shut it off or if it misfires, surges, stalls, or backfires.

Information about your vehicle's emissions control system is on the Vehicle Emission Control Information decal located on or near the engine. This decal identifies engine displacement and gives some tune-up specifications.

Readiness for Inspection/Maintenance Testing

In some localities it may become a legal requirement to pass an Inspection/Maintenance (I/M) test of the On-Board Diagnostic (OBD) II system. If the vehicle's powertrain system or its battery has just been serviced, the OBD II system is reset to a not ready for I/M testing condition. To prepare for I/M testing, the law specifies a "need for additional mixed city and highway driving to complete the check" of the OBD II system. As soon as all of the OBD II system checks are successfully completed, the OBD II system is set to the ready condition. The amount of driving required to reach the ready condition varies with individual driving patterns. To complete this requirement in the minimum amount of time, refer to the OBD II Drive Cycle defined below. If the vehicle owner cannot or does not want to do the additional driving required by law, a service center can perform this drive cycle as it would any other type of repair work.

OBD II Drive Cycle

The following steps must be run in the order shown. If any steps are interrupted, repeat the preceding step. Any safe driving mode is acceptable between steps.

Always drive vehicle in safe manner according to traffic conditions and obey all traffic laws.

The engine must be warmed up and at operating temperature before proceeding with the drive modes of the following OBD II Drive Cycle.

Servicing Your Villager

1. Start the engine. Drive or idle (in neutral) the vehicle for 4 minutes.
2. Idle the vehicle in drive for 40 seconds.
3. Accelerate the vehicle to 45 mph (70 km/h) at 1/4 to 1/2 throttle for 10 seconds.
4. Drive the vehicle with a steady throttle at 45 mph (70 km/h) for 30 seconds.
5. Idle the vehicle in drive for 40 seconds.
6. Continue to drive the vehicle in city traffic at speeds between 25 and 40 mph (40-60 km/h) for 15 minutes. During the 15 minute drive cycle the following modes must be achieved:
 - a. at least 5 stop and idle modes at 10 seconds each
 - b. acceleration from idles at 1/4 to 1/2 throttle position, and
 - c. choose 3 different speeds to do 1.5 minute steady state throttle drives.
7. Accelerate the vehicle up to between 45 and 60 mph (70-100 km/h). This should take approximately 5 minutes.
8. Drive vehicle and hold the throttle steady at the selected speed between 45 and 60 mph (70-100 km/h) for approximately 5 minutes.
9. Drive the vehicle for 5 minutes at varying speeds between 45 and 60 mph (70-100 km/h).
10. Bring the vehicle back to idle. Idle in Drive for 40 seconds.
11. OBD II drive cycle has been completed. Vehicle can be turned off when convenient.

Refill Capacities, Motorcraft Parts, and Lubricant Specifications

3.0L Engine		
Component	U.S.	Metric
Cooling system		
With trailer package, without rear heater	11.6 qts.	11.0 liters
With trailer package, with rear heater	13.0 qts.	12.3 liters
Without trailer package, without rear heater	10.7 qts.	10.1 liters
Without trailer package, with rear heater	12.1 qts.	11.4 liters
Engine oil		
With filter change	4.2 qts.	4.0 liters
Fuel tank (gallons/liters)	20 gal.	75.7 liters
Power steering	2.5 pts.	1.2 liters
Radiator cap	13 psi	90 kPa
Transaxle fluid		
Automatic overdrive	8.8 qts.	8.3 liters

For information on air conditioning refrigerant, contact your dealer.

Servicing Your Villager

Motorcraft Parts

Component	Part Number
Air filter	FA-1121
Battery	
Standard	BX-35
Optional	BX-24F
Fuel filter	FG-895
Oil filter	FL-839
PCV valve	EV-217
Spark plugs (.034 in.)	AGSP-32C or AGRP-32C

Lubricant Specifications

Item	Part Name	Ford Part No.	Specification
Brake Master Cylinder	Ford High Performance DOT 3 Brake Fluid	C6AZ-19542-AA	ESA-M6C25-A
Constant Velocity Joints	Constant Velocity Joint Grease	E43Z-19590-A	ESP-M1C207-A
Door Weatherstrips	Silicone Lubricant	C0AZ-19553-AA	ESR-M13P4-A
Engine Coolant	Premium Cooling System Fluid	E2FZ-19549-AA	ESE-M97B44-A
Engine Oil	Motorcraft Super Premium 5W-30 and 10W-30	XO-5W30-QSP and XO-10W30-QSP	WSS-M2C153-F and API-SG
Hinges and Latches	Multi-Purpose Grease Spray	D7AZ-19584-AA	ESR-M1C159-A and ESB-M1C93-A
Lock Cylinders	Penetrating Lubricant	E8AZ-19A501-B	—
Power Steering Pump Reservoir	Ford Premium Power Steering Fluid	E6AZ-19582-AA	ESW-M2C33-F
Transaxle, Automatic	Motorcraft MERCON®	XT-2-QDX	MERCON®
Wheel Bearings, Rear	Motorcraft Premium Long-life Grease	XG-1-C or XG-1-K	ESA-M1C75-B
Windshield Washer Reservoir	Ultra-clear Windshield Washer Concentrate	C9AZ-19550-AA or C9AZ-19550-BA	ESR-M17P5-A

Vehicle Storage

Maintenance Tips

If you plan on storing your vehicle for an extended period of time (60 days or more), refer to the following maintenance recommendations to keep your vehicle in good operating condition.

General

- Store your vehicle in a dry, ventilated place.
- Protect from sunlight, if possible.
- When your vehicle is stored outside, it will require regular maintenance to protect against rust and damage.

Body

- Wash your vehicle thoroughly to remove dirt, grease, oil, tar or mud from exterior surfaces, rear wheel housings and underside of front fenders.
- Touch-up raw or primed metal to prevent rust.
- Cover chrome and stainless steel parts with a thick coat of auto wax to prevent discoloration. Re-wax as necessary when your vehicle is washed.
- Lubricate all hood, door and trunk lid hinges and latches with a light grade oil.
- Cover interior soft trim to prevent fading.
- Keep all rubber parts free from oil and solvents.

Engine

- Start the engine every fifteen days. Run it at fast idle until it reaches normal operating temperature.
- With your foot on the brake, shift the transaxle into all gears while the engine is running.

Fuel system

- Fill fuel tank with high-quality unleaded fuel until the first automatic shutoff of the fuel pump nozzle.

NOTE: During extended periods of vehicle storage (60 days or more), fuel may deteriorate due to oxidation. This can damage rubber and other polymers in the fuel system and may also clog small orifices.

Ford Gas Stabilizer should be added whenever actual or expected storage periods exceed 60 days. Follow the instructions on the label. The vehicle should then be operated at idle speed to circulate the additive throughout the fuel system.

A volatile corrosion inhibitor added to the fuel system will protect the fuel system's inner surfaces from corrosion. Follow the instructions packaged with the product.

Cooling system

- Protect your vehicle against freezing temperatures.

Battery

- Check and recharge the battery as necessary.
- Keep connections clean and covered with a light coat of grease.

Servicing Your Villager

Brakes

- Make sure the brakes and parking brake are fully released.

Tires

- Maintain recommended air pressure.

Miscellaneous

- Make sure all linkages, cables, levers and clevis pins under the vehicle are covered with grease to prevent rust.
- Lubricate working parts to prevent corrosion.

**YOU FOUND
THE RIGHT PLACE.**



**Quality Care is more
than automotive service.**

**It's our goal to make you so
happy with your vehicle
and our service, you'll want
to come back. For service.
And your next vehicle.**

**Quality Care.
It's at your dealer.**



QUALITY CARE



© 1995 Ford Motor Company

Quick Index

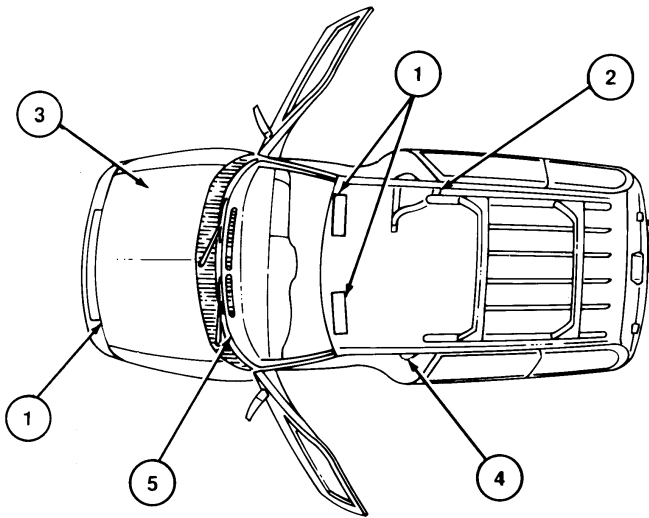

QUICK INDEX

No.	Description	Refer to this label for information regarding:
1	Air Bag Warning Labels	Air bag precautions
2	Child Seat Label	Child seat installation precautions
3	Fuel Pump Shut Off Label	Fuel pump shut off location
4	Safety Compliance Certification Label	Name and date of manufacturer, GVWR*, GAWR**, wheel and tire information
5	Vehicle Identification Number (VIN) Label	Servicing or warranty information specific to your vehicle
* Gross Vehicle Rating		** Gross Axle Weight Rating

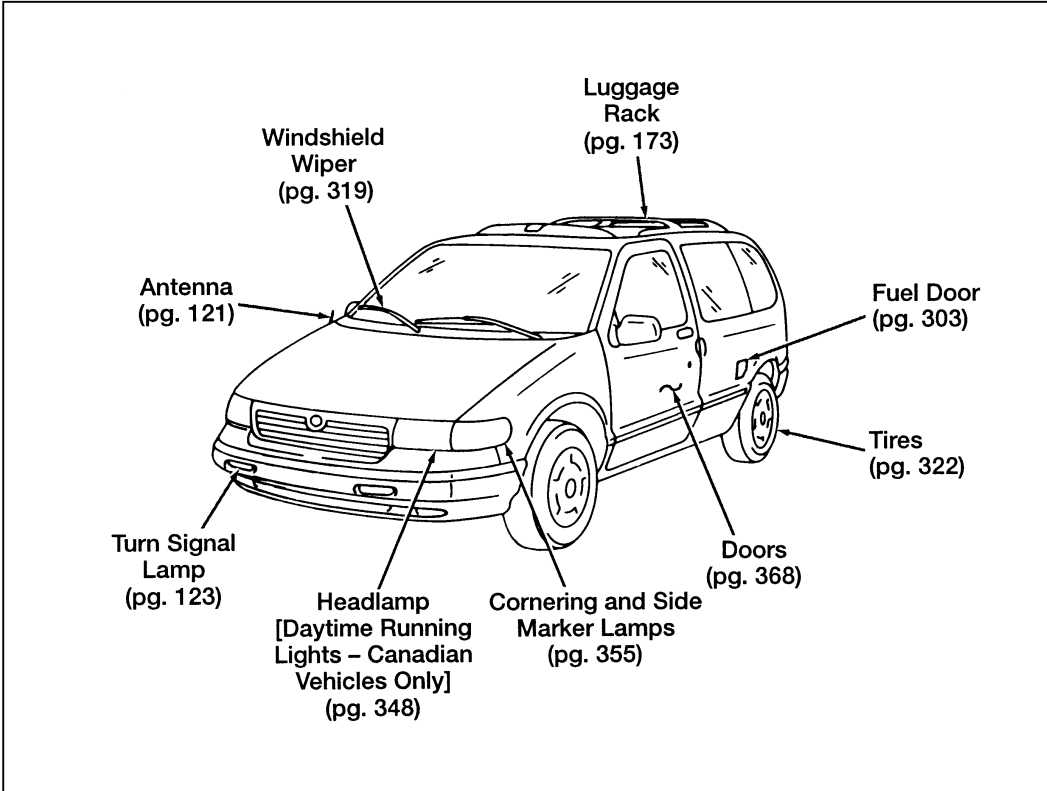

Rear Exterior View

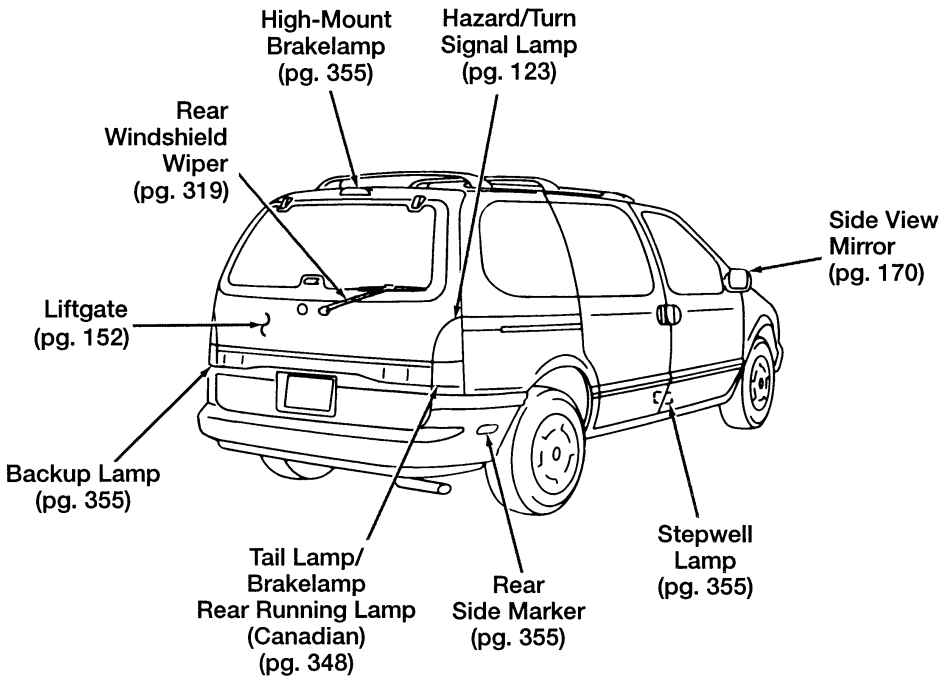

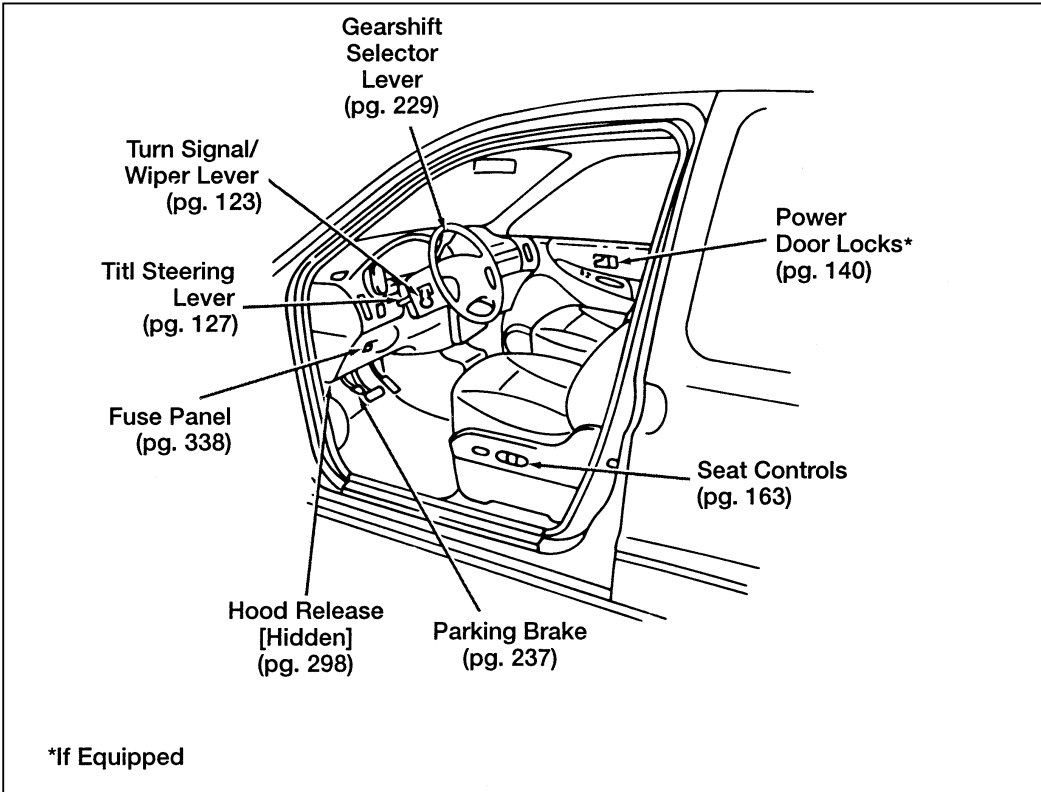

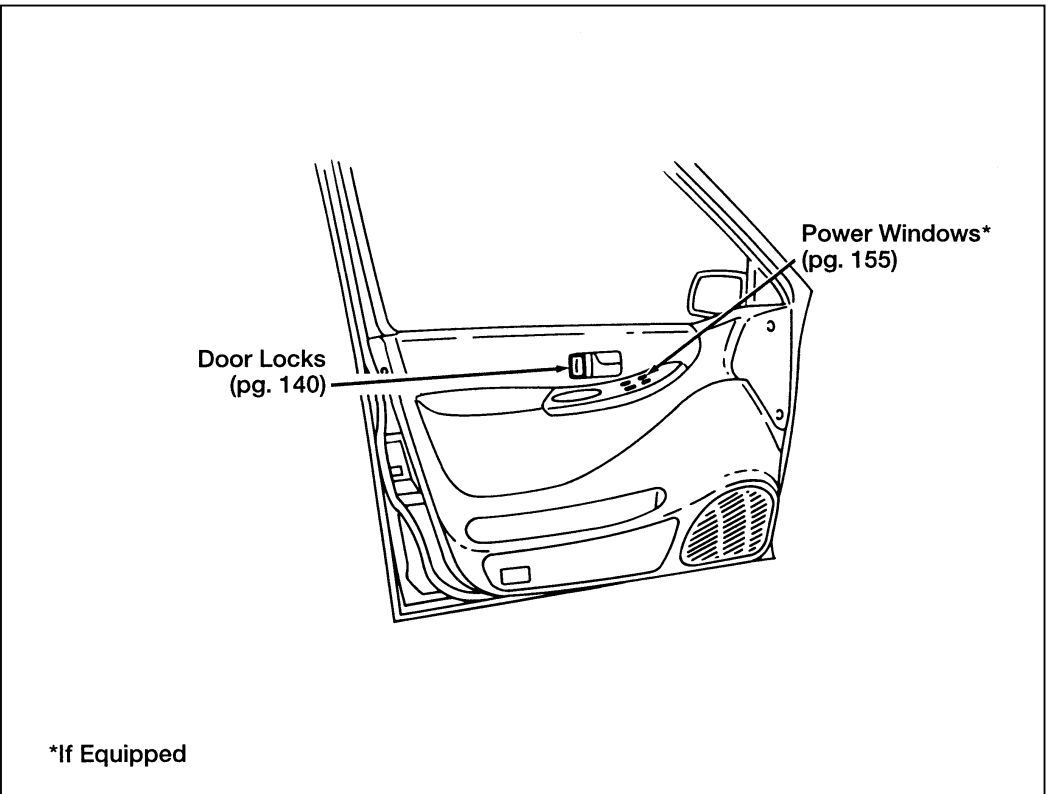

Driver's Door

***If Equipped**

Instrument Panel

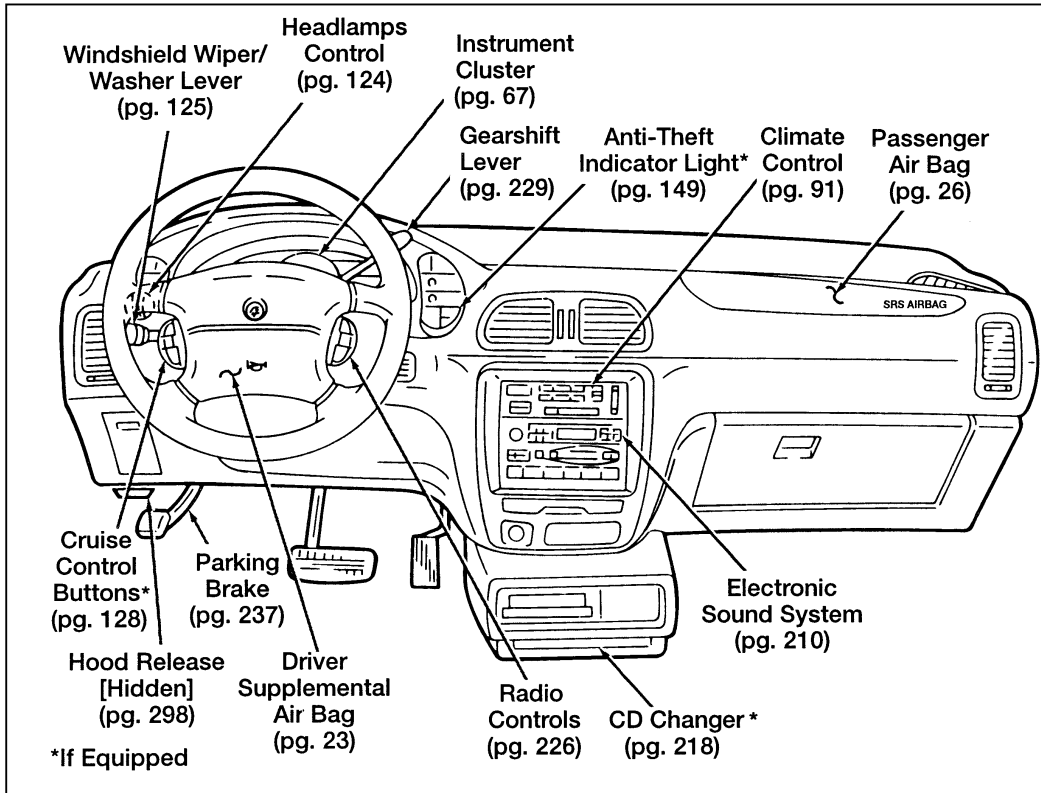

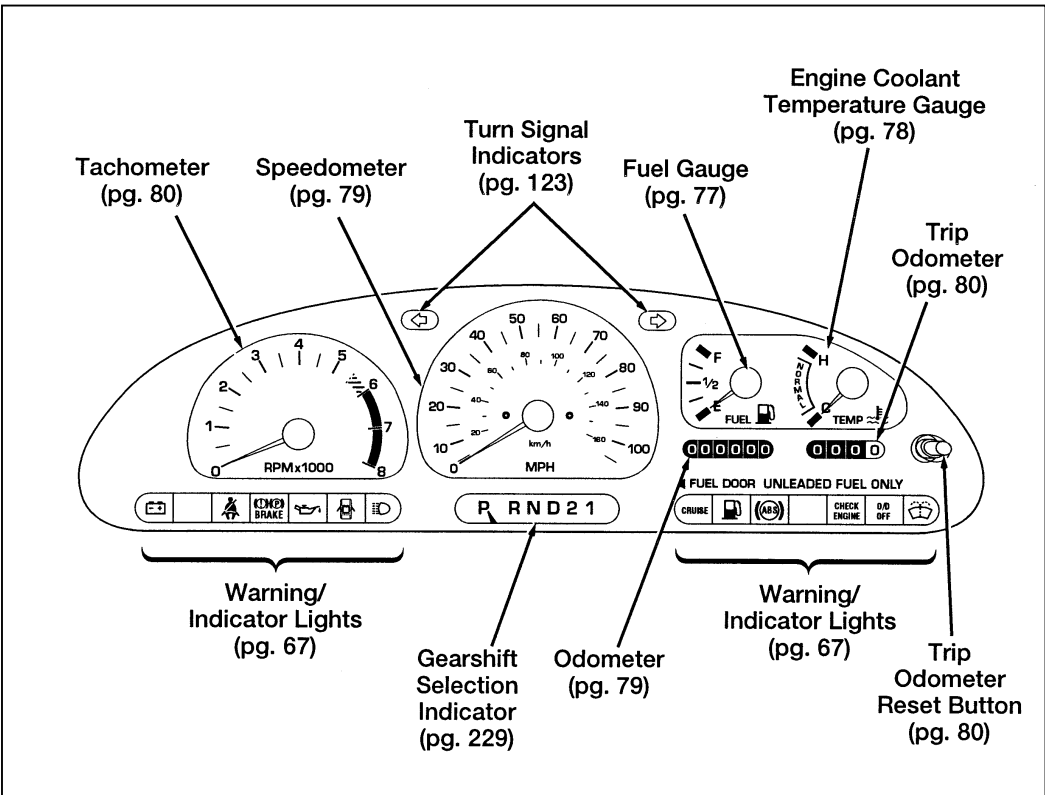

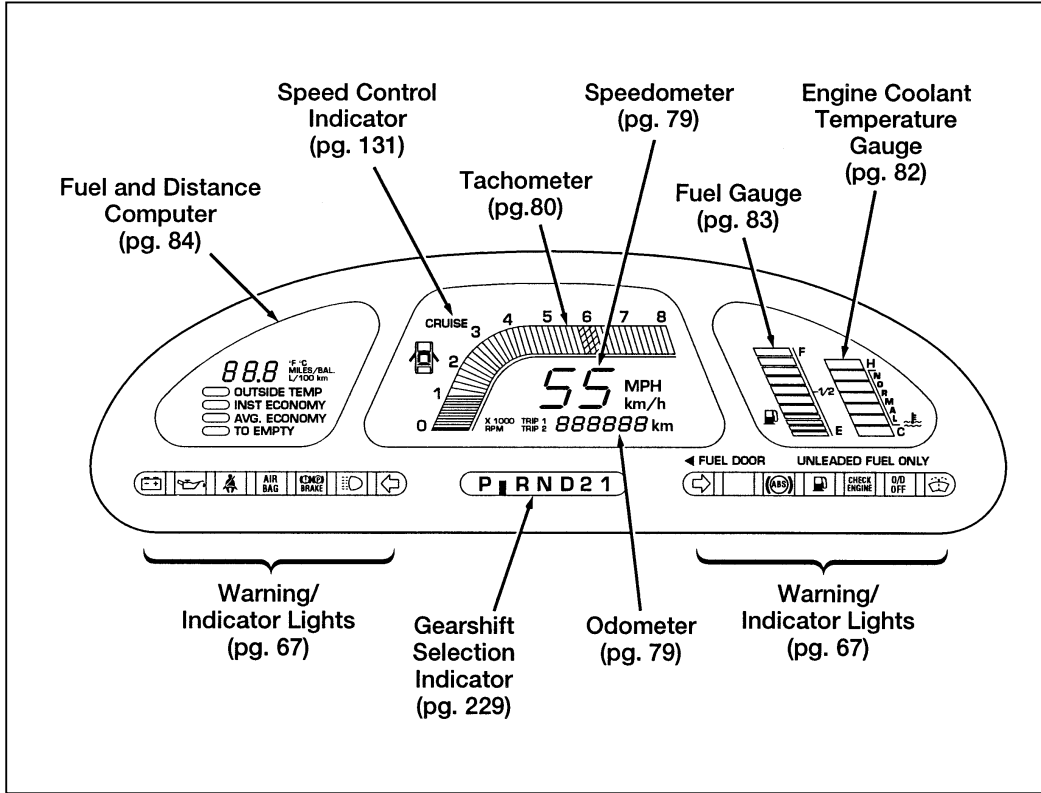

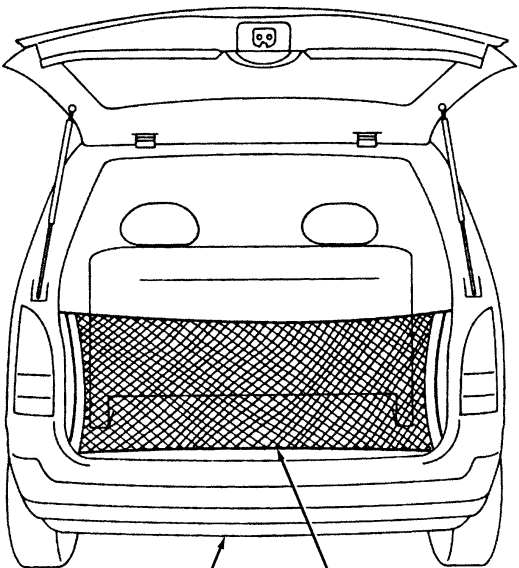

Spare Tire
(Under Vehicle)
(pg. 261)

Rear Cargo Net*
(pg. 171)

*If Equipped

Cargo Compartment

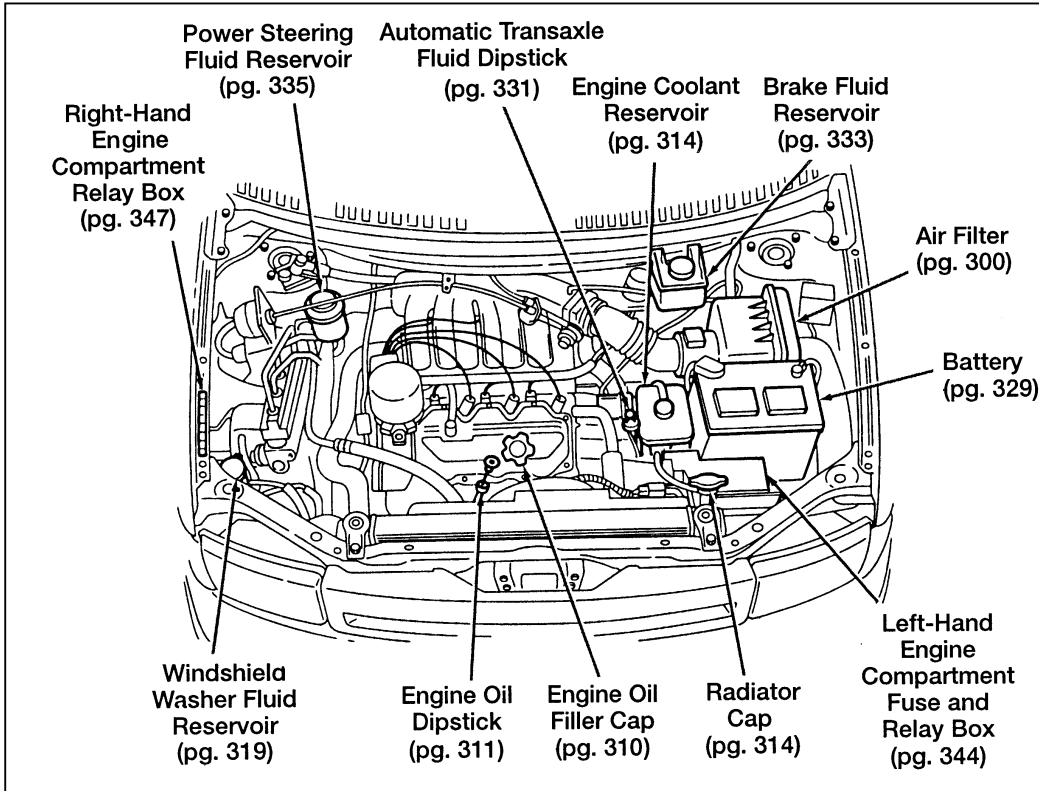

A

ABS warning light (see Anti-lock brake system)	70
Accessory position on the ignition.	57
Additives, engine oil.	310
Air bag supplemental restraint system	
and child safety seats	25, 32
description	23, 26
driver air bag.	23, 26
indicator light.	71
operation.	26
passenger air bag	26
proper seating	24
service and information labels	26
tone generator	30
wearing safety belts	24
Air cleaner filter, location	300
Antenna, radio (see Electronic sound system).	121, 205, 226
Antifreeze (see Engine coolant)	314
Anti-lock brake system (ABS)	
description	234
noise.	235
see also Brake.	234
warning light	70
Anti-theft lug nuts and key.	267
Appeals (see Dispute settlement board)	278
Assistance (see Customer assistance).	275
Audio system (see Electronic sound system)	205

Automatic transaxle	
driving with	229
fluid, adding	331, 333
fluid, checking	331
fluid, specification.	368

B

Backing up	230
Battery	
acid, treating emergencies	255, 330
charging system warning light	73
disconnecting.	259
how to service	329
proper disposal, recycling	330
servicing	329
voltage gauge	73
when storing your vehicle	370
Brake fluid	
brake warning light	69
checking and adding	333
description	333
specifications	334, 368
Brakes	
adjustment	234
anti-lock	234
anti-lock brake system (ABS) warning light	70
applying the brakes	237
brake warning light	69
fluid, checking and adding.	333
fluid, refill capacities	333
fluid, specifications	334, 368
front disc.	234
if brakes do not grip well	236
lubricant specifications.	368

Index

Brakes (continued)	
new brake linings	5
noise	234, 236
parking	237
power braking	234
servicing	236, 333
stopping distances	236
trailer	251
when storing your vehicle	371
Brights (high beams)	77, 124
Bulbs, replacing	
halogen	349
headlamps	349
specifications	355

C

Canada, customer assistance	282
Carbon monoxide in exhaust	64
Cargo net	171
Car seats for children (see Child safety seats)	32
Catalytic converter	362
Chains, tires	328
Changing a tire	259
Charging system warning light	73
Childproof locks	139
Child safety restraints	31
child safety belts	44
child safety seats	32
Child safety seats	
and air bags	25, 32
attaching with tether straps	39
automatic locking mode (retractor)	16, 32
in front seat	25, 32
in rear outboard seat	32
in rear seat	32
tether anchorage hardware	39

Chime	
headlamps on	77
key in ignition	58
safety belt	70
Circuit breakers	
checking and replacing	346
see also fuses	337
Cleaning your vehicle	
chrome and aluminum parts	7
engine compartment.	302
exterior	6
exterior lamps	114
fabric	165
headlamps	114
instrument panel	7
plastic parts	7
polishing.	6
rustproofing	7
safety belts	23
tail lamps	114
upholstery and interior trim	165
washing	6
waxing.	6
wheels	329
Climate control system	
air conditioning.	91
heating.	91
Clock.	217
Clutch, fluid reservoir	333
Cold engine starting.	60
Combination lap and shoulder belts.	9, 11
Controls	
instrument panel	89
mirrors.	169
steering column.	123

Index

Coolant (see Engine coolant)	
checking and adding	314
drain and flush	318
preparing for storage	370
specifications	368
temperature gauge	78, 82
warnings	314
Cooling fan	296
Cruise control (see Speed control).	128
Customer Assistance Centre, Ford of Canada.	282

D

Dashboard (see Instrument panel).	89
Daytime running light system	114
Defrost, windshield	91
Dipstick	
automatic transaxle fluid.	331
engine oil	311
power steering fluid.	335
Disabled vehicle (see Towing).	273
Dispute Settlement Board.	278
Doors	
door ajar warning light	74
lubricant specifications.	368
Driving under special conditions	
bad weather	240
heavy load	241
high speed	240
high water	241
slippery roads	240
tips for safe driving	239
towing a trailer	242

E

Electrical system	
circuit breakers	346
fuses.	337–338
relays	347
Electronic sound system	
antenna	121
radio reception	226
tuning the radio	210
warranty and service information.	228
Emergencies, roadside	
assistance	275
battery acid spills	255, 331
fuel	307
towing	273
Emergency brake (parking brake)	237
Emission control system	
catalytic converter.	362
emissions warranty	362
Engine	
check engine warning light	72
does not start.	61, 63
fuel injected engine, starting	59
fuel pump shut-off switch	63
preparing to start	59
service points.	300
starting	60
starting after a collision	273
storing your vehicle	369
Engine block heater	62
Engine coolant	314
checking and adding	314
disposal	296
drain and flush	318

Index

Engine coolant (continued)	
preparing for storage	370
proper solution	333
recovery reservoir	300, 314
specifications	368
temperature gauge	78, 82
Engine coolant temperature gauge	
description	78, 82
mechanical	78, 82
Engine coolant temperature guage:electronic	78, 82
Engine fan	296
Engine:idle speed control	62
Engine oil	
changing oil and oil filter	311, 313
checking and adding	311
dipstick	311
disposal	296, 333
engine oil pressure warning light	73
filter, specifications	367
specifications	310
synthetic oil	310
“break-in” oils	5
viscosity	310
Entry system, illuminated	120
Exhaust fumes.	64

F

Fan, engine fan, avoiding injury.	296
Federal Communications Commission	228
Flashers, hazard	112
Flashing the lamps.	124
Flat tire.	259
Ford Dispute Settlement Board	278
Ford Motor Company of Canada	282

Ford of Canada Customer Assistance Centre	282
Foreign registration	284
French owner guides, how to obtain	3
Fuel	
calculating fuel economy.	308
choosing the right fuel	305
filling your vehicle with fuel.	303
filter, specifications	367
fuel filler door release lever	303, 367
fuel gauge	77, 83
low fuel warning light.	76
octane rating	305
quality.	305
running out of fuel	308
safety information relating to automotive fuels.	307
storing your vehicle.	370
treating emergencies.	307
Fuel cap	
removing.	303
replacing.	303
Fuel filler door	303
remote release	303
Fuel filter, specifications	367
Fuel gauge	77, 83
Fuel pump shut-off switch	
engine does not start	273
starting after a collision	273
Fuse panels	
engine compartment.	344
instrument panel	338
Fuses	
charts	338
checking and replacing	337
circuit breakers	346

G

Gas cap (see Fuel cap)	303
Gas mileage (see Fuel economy)	305, 308
Gasoline (see Fuel).	303
Gauges, Electronic	
engine coolant temperature gauge	78, 82
fuel gauge	77, 83
odometer	79
speedometer	79
Gauges, Mechanical	
engine coolant temperature gauge	78, 82
fuel gauge	77, 83
odometer	79
speedometer	79
tachometer	80
trip odometer	80
GAWR (Gross Axle Weight Rating)	
calculating	247
definition	241, 245
driving with a heavy load	241
Gearshift	
automatic operation	229
column-mounted	229
locking the gearshift	57
positions	229
shifting the gears	229
Gearshift:shifting the gears	229
GVWR (Gross Vehicle Weight Rating)	
calculating	247
definition	241, 245
driving with a heavy load	241

H

Hazard flashers	112
Headlamps	
aiming	348
bulb specification	355
checking alignment	348
cleaning	114
daytime running lights	114
high beam	124
replacing bulbs	348
warning chime	77
Head restraints	159
Heating, manual heating and air conditioning system.	91
High beams	
indicator light	77
operation.	124
Hitch.	250
Hood	
latch location	298
lubrication specifications	368
release lever	298
working under the hood.	296

I

Identification Number, Vehicle (VIN)	277, 283
Idle	
relearning	259, 296
speed	62
Ignition	
chime	58
positions of the ignition	57
removing the key	58
Infant seats (see Safety seats)	31
Instrument cluster	67
electronic.	81

Index

Instrument panel	
lighting up panel and interior	115
location of components	89
Interval wipers	125

J

Jack, operation	263
Jump-starting your vehicle	
attaching cables	257
disconnecting cables	259

K

Keyless entry system	
locking and unlocking doors	144
programming entry code.	143
Keys	
key in ignition chime	58
positions of the ignition	57
removing from the ignition	58
stuck in lock position	57

L

Lamps	
bulb replacement specifications chart	355
checking	348
daytime running light system	114
hazard flashers	112
high beams	124
illuminated entry system.	120
instrument panel, dimming.	115
replacing bulbs	348
trailer	251
Lane change indicator (see Turn signal)	123
Liftgate	152

Lights, warning and indicator	
air bag	71
anti-lock brakes (ABS)	70
brake	69
charging system	73
check engine	72
door ajar	74
engine oil pressure	73
hazard warning light	112
high beam	77
low fuel	76
oil pressure.	73
rear ABS	70
safety belt	70
turn signal indicator.	123
Load limits	
GAWR	241
GVWR	241
trailer towing.	249
Lubricant specifications	368
Luggage rack	173
Lug nuts	
anti-theft	267
tightening sequence	271

M

Maintenance (see Servicing)	295
Map pockets	166
Master cylinder, brakes	333
Mileage, calculating fuel economy.	308
Mirrors	
automatic dimming rearview mirror	139
dual electric remote control	170
rearview	169
side view mirrors (manual)	170
side view mirrors (power)	170
Motorcraft parts.	367

Index

O

Octane rating	305
Odometer	
description	79
trip odometer	80
Oil filter	313
Oil (see Engine oil)	310
Oil viscosity.	310
On-board diagnostic (OBD II) system	364
Overdrive.	231
Overseas offices	284

P

Parking brake	
operation	237
warning light	69
Parts (see Motorcraft Parts).	367
PCV valve, specifications	367
Power door locks	140
Power features	
door locks	140
mirrors.	169
windows	155
Power steering	
dipstick	335
driving with power steering	234
fluid, checking and adding.	335
fluid, specifications	368
servicing	234
Prop rod, hood	298

R

Radio (see Electronic sound systems)	205
Rear window	155
washer reservoir	319
Relays	347
Remote entry system, illuminated entry	120
Restraints, safety (see Safety restraints)	
adult.	9
child.	31
head.	159
infant	31
Roadside assistance	275
Roadside emergencies	255
Roof rack	173
Rotating the tires	323

S

Safe driving tips.	239
Safety belts (see Safety restraints)	9
Safety Compliance Certification Label	247
Safety information relating to automotive fuels.	307
Safety restraints	
adjusting the safety belts	11, 17
automatic locking mode	16
automatic locking mode (retractor)	16
cleaning the safety belts	23
extension assembly	22
for adults	9
for children.	31
for infants	31
for pregnant women	9
head.	159
lap and shoulder belts.	9, 11

Index

Safety restraints (continued)	
maintenance	23
proper use	9
replacement.	23
warning light and chime.	70
Safety seats for children	32
and air bags	25, 32
attaching with tether straps	39
automatic locking mode (retractor)	16, 32
in front seat	32
in rear outboard	32
in rear seat	32
tether anchorage hardware	39
Seat belts (see Safety restraints)	9
Seats	
child safety seats	32
cleaning upholstery	165
head restraints	159
Serial number (VIN)	283
Service concerns	276
Servicing your vehicle	
precautions when servicing.	296
servicing when you tow	273
Shift positions (see Gearshift)	229
Shoulder and lap belts (see Safety restraints)	9, 11
Shoulder belts (see Safety restraints).	11, 17
Side mirrors, adjusting	170
Snow tires and chains	328
Spare tire	
changing the tire	259, 263
conventional spare	259
finding the spare	261
removing the spare tire	261
temporary spare.	260

Spark plugs, specifications	367
Special driving conditions	239
Specification chart, lubricants	368
Speed control	
accelerating	131
canceling a set speed	132
resetting	132
resuming a set speed	132
tap up/tap down	132
when towing a trailer	252
Speedometer	79
Starting your vehicle	
preparing to start your vehicle	59
starting a cold engine	60
starting after a collision	273
Steering, power	234
Steering wheel	
locking	57
speed controls	128
Storage compartments	
cargo net	171
map pockets	166
Storing your vehicle	369
Supplemental air bag readiness light	71
Supplemental Restraint System (SRS)	23

T

Tachometer	80
mechanical cluster	80
Tail lamps	
bulb replacement	348, 355
cleaning	114
Temperature control (see Climate control)	91
Tether anchor installation (see Child restraints).	39
Tires	
changing	259
checking the pressure	322
cleaning	329

Index

Tires (continued)	
inspection and maintenance	322
replacing	324
rotating	323
snow tires and chains	328
spare tire	261
storing your vehicle	371
tire grades	324, 326
treadwear	324, 326
wear bands	324
wheel and tire matching	325
Towing a trailer (see Trailer towing)	242
Towing your vehicle	
with a tow truck	273
Trailer Towing	242
Trailer towing	
tips	252
trailer brakes	251
trailer lamps	251
Transaxle	
automatic operation	229
fluid, checking and adding (automatic)	331
lubricant specifications	368
Transaxle control switch	231
Trip odometer	80
Turn signal	
indicator lights	123
lever	123

U

Used engine oil, disposal 296, 333

V

Variable interval wipers 125

Vehicle Identification Number (VIN) 277, 283

Vehicle loading, calculating the load 247

Vehicle storage 369

Ventilating your vehicle (see Climate control) 91

Viscosity (see Engine oil). 310

Voltmeter (see Battery voltage gauge) 73

W

Warning chimes

 headlamps on 77

 key in ignition 58

 safety belt 70

Warning lights (see Lights) 67

Warranties, radio 228

Warranty Information Booklet 4

Washer fluid

 rear window reservoir 319

 reservoir 319

 windshield 319

Weight limits (GAWR, GVWR) 241

Wheel and tire matching 325

Wheel bearings lubricant specifications 368

Wheel dollies (see Towing) 273

Wheels 325

 anti-theft lugnuts 267

 cleaning 329

 inspection and maintenance 322

 lug nuts 263

 replacement 325

Index

Windows	
power windows, operating	155
Windshield, washing	125
Windshield washer fluid and wipers	
checking and adding fluid	319
checking and replacing wiper blades	320
liftgate reservoir.	319
operation	125
reservoir	319
specifications	320
variable interval wipers	125
Windshield wipers and washer	125
Wrecker towing	273

Service Station Information

Engine Size & Type	3.0 Liter 12V (2 valves per cylinder), EFI (Electronic Fuel Injection), 6 Cylinder, 180.6 Cubic Inch Displacement (CID)
Fuel	UNLEADED FUEL ONLY — Octane 87 or higher
Fuel Tank Capacity	20 gallons (75.7 liters)
Engine Oil	Use only engine oil displaying the American Petroleum Institute Certification Mark SAE 5W-30 is preferred.
Engine Oil Capacity	4.2 quarts (4.0 liters) with filter change
Engine Coolant Capacity	Coolant capacity depends on optional trailer package and optional rear heater. Refer to the refill capacities chart for your vehicle's capacity.
Tire Size & Pressure	See the Safety Compliance Certification Label on the driver's door pillar.
Brake Fluid	Use only brake fluid that meets Ford's Specification ESA-M6C25-A.
Power Steering Fluid	Use only power steering fluid that meets Ford's Specification ESW-M2C33-F, such as Ford Premium Power Steering Fluid, E6AZ-19582-AA or equivalent.
Automatic Transaxle Fluid	Motorcraft MERCON® type fluid (ATF)
Hood Release	Pull the handle under the left side of the instrument panel.