



2021 MODELS NEW MEDIUM DUTY



MODEL

535

MODEL

536

MODEL

537

MODEL

548

Release Date 5/3/2021

This page is intentionally left blank.

BODY BUILDER MANUAL CONTENTS

SECTION 1: INTRODUCTION

SECTION 2: SAFETY AND COMPLIANCE

SAFETY SIGNALS	2-1
FEDERAL MOTOR VEHICLE SAFETY STANDARDS AND COMPLIANCE	2-2
NOISE AND EMISSIONS REQUIREMENTS	2-3
FUEL SYSTEM	2-4
COMPRESSED AIR SYSTEM	2-4
EXHAUST AND EXHAUST AFTERTREATMENT SYSTEM	2-5
COOLING SYSTEM	2-6
AIR INTAKE SYSTEM	2-6
CHARGE AIR COOLER SYSTEM	2-6
ELECTRICAL SYSTEM	2-7
GENERAL WIRE ROUTING	2-8
SAFETY RELATED COMPONENTS AND SYSTEMS	2-8

SECTION 3: DIMENSIONS

INTRODUCTION	3-1
ABBREVIATIONS	3-1
OVERALL DIMENSIONS	3-1
MODELS 535, 536, 537, & 548 – 107" BBC AERO HOOD	3-2
MODELS 536, 537, & 548 – 109" BBC AERO HOOD	3-3
MODELS 537 & 548 – 109" VOC HOOD	3-4
MODELS 537 & 548 – VOC HOOD W/ 24" FEPTO BUMPER EXTENSION	3-5
CAB – 2.1m MEDIUM DUTY CAB FAMILY	3-6
REAR WINDOW	3-7
CAB SUSPENSION	3-8
CAB STEP HEIGHT	3-9
FRAME RAILS	3-10
FRAME HEIGHT CHARTS	3-11
FRONT FRAME HEIGHTS "A"	3-12
REAR FRAME HEIGHTS "C"	3-13
FRAME MOUNTED COMPONENT GROUND CLEARANCE	3-15
FRAME SPACE REQUIREMENTS	3-16
FRAME SPACE DIMENSION "B"	3-17
FRAME SPACE DIMENSION "A"	3-18
FRAME SPACE DIMENSION "C"	3-20
2021 MD EXHAUST CONFIGURATIONS	3-24
TURN RADIUS ANALYSIS	3-34

SECTION 4: BODY MOUNTING

INTRODUCTION	4-1
FRAME RAILS	4-1
CRITICAL CLEARANCES	4-2
BODY MOUNTING USING BRACKETS	4-3
FRAME SILL	4-3
BRACKETS	4-4
MOUNTING HOLES	4-5
FRAME DRILLING	4-6
BODY MOUNTING USING U-BOLTS	4-7
REAR BODY MOUNT	4-9

TABLE OF CONTENTS

SECTION 5: FRAME MODIFICATIONS

INTRODUCTION	5-1
DRILLING RAILS	5-1
MODIFYING FRAME LENGTH	5-2
CHANGING WHEELBASE	5-2
CROSSMEMBERS	5-3
TORQUE REQUIREMENTS	5-4
WELDING	5-4
PRECAUTIONS	5-5

SECTION 6: CAN COMMUNICATIONS

INTRODUCTION	6-1
CAN COMMUNICATIONS ACRONYM LIBRARY	6-1
SAE J1939	6-2
PARAMETER GROUP NUMBER	6-2
SUSPECT PARAMETER NUMBER	6-2
CAN MESSAGES AVAILABLE ON BODY CONNECTIONS	6-3

SECTION 7: ELECTRICAL

INTRODUCTION	7-1
ELECTRICAL ACRONYM LIBRARY	7-1
ELECTRICAL WIRING CIRCUIT CODES	7-2
MULTIPLEX SYSTEM	7-3
CAN BUS SYSTEM OVERVIEW	7-3
CAN BUS SPEEDS AND CIRCUIT DESIGNATION	7-3
ELECTRICAL COMPONENT OVERVIEW	7-4
ELECTRICAL HARNESS OVERVIEW	7-5
IN CAB CAN BASED MESSAGING CONNECTOR – RP1226	7-6
BODY CONNECTION POINTS – MAIN CHASSIS HARNESS	7-7
ELECTRIC ENGAGED EQUIPMENT	7-11
RP170 CONNECTOR	7-11
ENGINE HARNESS 12 PIN CONNECTOR	7-12
POWER DISTRIBUTION CENTER	7-15
ENGINE SIDE FUSE BOX FULL COMPONENT POPULATION	7-17
DASH SIDE FUSE BOX FULL COMPONENT POPULATION	7-18
CHASSIS MODULE	7-19
CHASSIS MODULE FUNCTION DESIGNATIONS	7-20
FUSE GROUPS	7-21
ELECTRIC OVER AIR SOLENOIDS	7-23
SOLENOID BANK DIAGRAM	7-23
SOLENOID OVERVIEW LAYOUT	7-24
MUX SOLENOID BANK FRAME MOUNTING	7-25
SWITCHES	7-26
SWITCH RELEARN PROCESS	7-27
GROUNDING	7-29
SPARE POWER	7-30
JUNCTION BOX	7-34
TRANSMISSION BACKUP SIGNALS	7-35
SNOW PLOW LIGHTING	7-35
LIFT AXLES (PUSHERS & TAGS)	7-36
LIFT AXLE DIAGRAM	7-36
LIFT AXLE LOGIC	7-36
TRAILER LIFT AXLE	7-37
DIGITAL DISPLAY	7-37
TELLTALE ICONS	7-38

TABLE OF CONTENTS

SECTION 8: POWER TAKE-OFF (PTO)

INTRODUCTION	8-1
PTO ACRONYM LIBRARY	8-1
TRANSMISSION MOUNTED PTO	8-2
MANUAL TRANSMISSIONS	8-2
AUTOMATIC TRANSMISSIONS - ALLISON	8-3
AUTOMATIC TRANSMISSIONS – PACCAR 8-SPEED	8-4
FRONT ENGINE PTO	8-5
PTO MOUNTING CLEARANCE	8-6
ALLISON PTO MOUNTING CLEARANCE	8-6
PACCAR PTO MOUNTING CLEARANCE	8-10
EATON PTO MOUNTING CLEARANCE	8-11
HYDRAULIC CLUTCH ACTUATOR CONFIGURATIONS	8-13
REAR ENGINE PTO	8-13
REMOTE PMC CONNECTIONS	8-14

SECTION 9: AFTERTREATMENT

INTRODUCTION	9-1
GENERAL GUIDELINES FOR DEF SYSTEM	9-1
DEF SYSTEM SCHEMATICS	9-2
INSTALLATION REQUIREMENTS AND DIMENSIONS FOR DEF SYSTEM	9-3
DEF ASSEMBLY RELOCATION - SUPPLY MODULE REQUIREMENTS	9-3
ROUTING TO THE DOSING MODULE (INJECTOR)	9-4

SECTION 10: ROUTING

INTRODUCTION	10-1
DEFINITIONS	10-1
ROUTING REQUIREMENTS	10-3
ROUTING OF WIRES AND HOSES NEAR EXHAUST SYSTEM	10-5

This page is intentionally left blank.

SECTION 1 INTRODUCTION



The Peterbilt Medium Duty Body Builder Manual was designed to provide body builders with a comprehensive information set to guide the body planning and installation process. Use this information when installing bodies or other associated equipment.

This manual contains appropriate dimensional information, guidelines for mounting bodies, modifying frames, electrical wiring information, and other information useful in the body installation process.

The Peterbilt Medium Duty Body Builder Manual can be very useful when specifying a vehicle, particularly when the body builder is involved in the vehicle definition and ordering process. Information in this manual will help reduce overall costs through optimized integration of the body installation with vehicle selection. Early in the process, professional body builders can often contribute valuable information that reduces the ultimate cost of the body installation.

In the interest of continuing product development, Peterbilt reserves the right to change specifications or products at any time without prior notice. It is the responsibility of the user to ensure that he is working with the latest released information. Check Peterbilt.com for the latest released version.

If you require additional information or reference materials, please contact your local Peterbilt dealer.

This page is intentionally left blank.

SECTION 2 SAFETY AND COMPLIANCE

SAFETY SIGNALS

There are a number of alerting messages in this book. Please read and follow them. They are there for your protection and informational reference. These alerting messages can help you avoid injury to yourself or others and help prevent costly damage to the vehicle.

Key symbols and “signal words” are used to indicate what kind of message is going to follow. Pay special attention to comments prefaced by “WARNING”, “CAUTION”, and “NOTE.” Please do not ignore any of these alerts.

Warnings, Cautions, and Notes

WARNING



When you see this word and symbol, the message that follows is especially vital. It signals a **potentially hazardous situation, which**, if not avoided, could result in death or serious injury. This message will tell you what the hazard is, what can happen if you do not heed the warning, and how to avoid it.

Example:

WARNING! Be sure to use a circuit breaker designed to meet liftgate amperage requirements. An incorrectly specified circuit breaker could result in an electrical overload or fire situation. Follow the liftgate installation instructions and use a circuit breaker with the recommended capacity.

CAUTION



Signals a potentially hazardous situation, which, if not avoided, could result in minor or moderate injury or damage to the vehicle.

Example:

CAUTION: Never use a torch to make a hole in the rail. Use the appropriate drill bit.

NOTE



Provides general information: for example, the note could warn you on how to avoid damaging your vehicle or how to drive the vehicle more efficiently.

Example:

NOTE: Be sure to provide maintenance access to the battery box and fuel tank fill neck.

Please take the time to read these messages when you see them, and remember:

WARNING

Indicates a potentially hazardous situation, which, if not avoided, could result in death or serious injury.

CAUTION

Signals a potentially hazardous situation, which, if not avoided, could result in minor or moderate injury or damage to the vehicle.

NOTE

Useful information that is related to the topic being discussed.

FEDERAL MOTOR VEHICLE SAFETY STANDARDS AND COMPLIANCE

As an Original Equipment Manufacturer, Peterbilt Motors Company ensures that our products comply with all applicable U.S. or Canadian Federal Motor Vehicle Safety Standards. However, the fact that this vehicle has no fifth wheel and that a Body Builder (Intermediate or Final Stage Manufacturer) will be doing additional modifications means that the vehicle was incomplete when it left the build plant.

INCOMPLETE VEHICLE CERTIFICATION

An Incomplete Vehicle Document is shipped with the vehicle, certifying that the vehicle is not complete. See Figure 2-1. In addition, affixed to the driver’s side door frame or edge is an Incomplete Vehicle Information label. See Figure 2-2.

NOTE



These documents list the U.S. or Canadian Federal Motor Vehicle Safety Standard regulations that the vehicle complied with when it left the build plant. You should be aware that if you add, modify or alter any of the components or systems covered by these regulations, it is your responsibility as the Intermediate or Final Stage Manufacturer to ensure that the complete vehicle is in compliance with the particular regulations upon completion of the modifications.



FIGURE 2-1. Incomplete Vehicle Document (IVD)

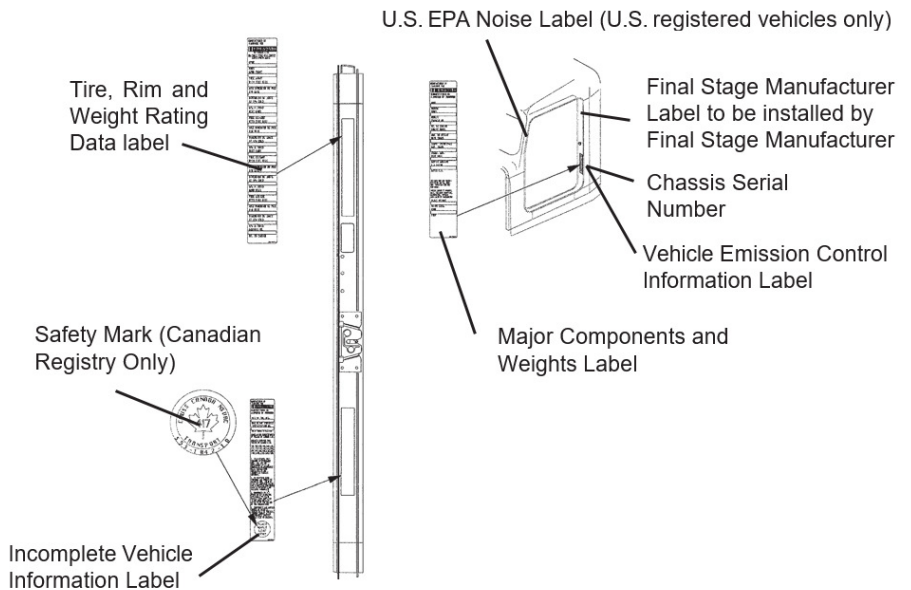

FIGURE 2-2. Locations of Information Labels - Driver's Door and Frame

As the Intermediate or Final Stage Manufacturer, you must retain the Incomplete Vehicle Document for your records. In addition, you must record and retain the manufacturer and serial number of the tires on the vehicle. Upon completion of the vehicle (installation of the body and any other modifications), you must affix your certification label to the vehicle as required by Federal law. This label identifies you as the “Intermediate or Final Stage Manufacturer” and certifies that the vehicle complies with Federal Motor Vehicle Safety Standards. (See Figure 2-2.) Be advised that regulations affecting the intermediate and final stage manufacturer may change without notice. Ensure you are referencing the most updated copy of the regulation during the certification and documentation processes.

In part, if the final stage manufacturer completes and can certify the vehicle with guidance provided in the incomplete vehicle document, the certification label would need a statement that reads, "This vehicle has been completed in accordance with the prior manufacturer's IVD where applicable. This vehicle conforms to all applicable Federal Motor Vehicle Safety Standards [and Bumper and Theft Prevention Standards if applicable] in effect in (month, year)."

However, if the vehicle cannot be completed and certified within the guidance provided in the IVD, the final stage manufacturer must ensure the vehicle conforms to all applicable Federal Motor Vehicle Safety Standards (FMVSS). The final stage manufacturer's certification label would need a statement that reads "This vehicle conforms to all applicable Federal Motor Vehicle Safety Standards [and Bumper and Theft Prevention Standards if applicable] in effect in (month, year).

These statements are just part of the certification regulation. Please refer to NHTSA/DOT Title 49 CFR part 567 - certification for all of the details related to this regulation.

For Canadian final stage manufacturers see:

<http://www.gazette.gc.ca/index-eng.html>; and
<http://www.tc.gc.ca/eng/acts-regulations/menu.htm> for the regulations.

Or contact: Transport Canada
Tower C, Place de Ville, 330 Sparks Street
Ottawa, Ontario K1A 0N5 (613) 990-2309
TTY: 1-888-675-6863

NOISE AND EMISSIONS REQUIREMENTS

NOTE



This truck may be equipped with specific emissions control components/systems in order to meet applicable Federal and California noise and exhaust emissions regulations established by the U.S. Code of Federal Regulations, Environment Canada, and the California Air Resources Board. These emissions control components/systems may only be replaced with original equipment parts.

Additionally, most vehicles in North America will be equipped with a Greenhouse Gas (GHG) "Vehicle Emission Control Information" door label indicating its certified configuration. The vehicle components listed on this label are considered emission control devices.

Modifying (i.e. altering, substituting, relocating) any of the emissions control components/systems defined above will affect the noise and emissions performance/certification. Modifications that alter the overall shape and aerodynamic performance of a tractor will also affect the emission certification. If modifications are required, they must first be approved by the manufacturer. Unapproved modifications could negatively affect emissions performance/certification. There is no guarantee that proposed modifications will be approved.

Tires may be substituted provided the new tires possess a Coefficient of rolling resistance (Crr) equal to or lower than Crr of the original tires. Consult with your tire supplier(s) for appropriate replacement tires.

Contact the engine manufacturer for any requirements and restrictions **prior** to any modifications.

- For Cummins, contact 1-800-DIESELS or your local Cummins distributor. Reference AEB 21.102.

It is possible to relocate the DEF tank; however, the relocation requirements in section 9 of this manual need to be followed. Any variances from the relocation requirements may cause the emissions control components/systems to operate improperly potentially resulting in engine de-rate.

NOTE

All engine emissions certified vehicles will be equipped with an On-Board Diagnostics (OBD) system. The OBD system is designed to detect malfunctions of any engine or vehicle component that may increase exhaust emissions or interfere with the proper performance of the OBD system itself.

All diesel engines will be equipped with an On-Board Diagnostics (OBD) system. The OBD system consists of computer program on one or more of the vehicle's Electronic Control Units (ECUs). This program uses information from the control system and from additional sensors to detect malfunctions. When a malfunction is detected, information is stored in the ECU(s) for diagnostic purposes. A Malfunction Indicator Light (MIL) is illuminated in the dash to alert the driver of the need for service of an emission-related component or system.

To ensure compliance to emissions regulations, the final configuration of certain features of the completed vehicle must meet specific requirements. This section describes requirements relevant for only the most common or critical modifications done by body builders. For a complete description of acceptable modifications, see the application guidance available from the manufacturer of the engine installed in the chassis.

FUEL SYSTEM

The following are highlights of some of the more common or critical aspects of this system.

The overall system restriction may not exceed the restriction limitations set forth by the engine manufacturer for both supply and return.

- Ensure that fuel lines are not pinched or can potentially be damaged when installed between body and frame
- Fuel lines must be routed and secured without dips or sags, and properly secured to prevent damage.
- There must be easy access to filter(s) and fill cap
- The tank vent may not obstructed
- Added accessories (heaters, generators) cannot introduce air into system
- Fuel tank must be located so that the fuel level is not above cylinder head
- "Ultra-Low Sulfur Fuel Only" labels must be present on the dash and fuel fill
- Modification of the pressure side secondary filter and plumbing is not allowed without engine manufacturer approval
- Body installation of fuel tank or routing of lines must not cause significant increase in fuel temperature
- Fuel hoses shall meet or exceed OEM supplied hose material construction specifications
- Care must be taken that fuel lines do not route against other components.

COMPRESSED AIR SYSTEM

The following are highlights of some of the more common or critical aspects of this system.

- Air system modification must meet applicable FMVSS regulations
- Compressed air tank may not be modified

- Added devices or bodywork may not interfere with or rub air lines
- Air supply to the engine doser may not be restricted or disconnected
- Air lines should be routed, protected from heat, and properly secured to prevent damage from other components
- Care should be taken so that air lines do not rub against other components
- Care should be taken to protect the air system from heat sources

EXHAUST AND EXHAUST AFTERTREATMENT SYSTEM

The following are highlights of some of the more common or critical aspects of this system.

- The following aftertreatment and exhaust system components may not be modified:
 - DPF/SCR assembly
 - Exhaust pipes between the engine and aftertreatment devices (DPF, SCR Catalyst) and between aftertreatment devices
 - NO_x Sensors
 - PM Sensor
- The following modifications may only be done within the guidelines outlined in section 9 of this manual:
 - Modifications to Diesel Exhaust Fluid (DEF) throttle, suction, or pressure lines
 - Modification or relocation of the DEF tank
 - Modification of coolant lines to and from the DEF tank
- All DEF and coolant lines should be routed, protected, and properly secured to prevent damage during vehicle operation or other components
- The DPF/SCR or its mounting may not be modified
- The NO_x sensor may not be relocated or altered in any way; this includes re-clocking the aftertreatment canister or reorienting the sensor(s)
- Exhaust pipes used for tailpipes/stacks must be properly sized, and must prevent water from entering
- Ensure adequate clearance between the exhaust and body panels, hoses, and wire harnesses (see routing section of this manual for more details)
- The body in the vicinity of the DPF must be able to withstand temperatures up to 400 °C (750 °F)
- Do not add thermal insulation to the external surface of the DPF
- The SCR water drain hole may not be blocked
- Allow adequate clearance (25mm (1 inch)) for servicing the DPF sensors, wiring, and clamped joints
- Drainage may not come in contact with the DPF/SCR, sensors, or wiring
- Allow sufficient clearance for removing sensors from DPF. Thermistors require four inches. Other sensors require one inch
- Wiring should be routed, protected from heat, and properly secured to prevent damage from other components
- The exhaust system from an auxiliary power unit (APU) must not be connected to any part of the vehicle aftertreatment system or vehicle tail pipe.

COOLING SYSTEM

The following are highlights of some of the more common or critical aspects of this system.

- Modifications to the design or locations of fill or vent lines, heater or defroster core, and surge tank are not recommended
- Additional accessories plumbed into the engine cooling system are not permitted, at the risk of voiding vehicle warranty
- Coolant level sensor tampering will void warranty
- When installing auxiliary equipment in front of the vehicle, or additional heat exchangers, ensure that adequate air flow is available to the vehicle cooling system. Refer to engine manufacturer application guidelines for further detail
- When installing FEPTO drivelines, the lower radiator anti-recirculation seal must be retained with FEPTO driveline clearance modification only
- Changes made to cooling fan circuit and controls are not allowed, with the exception of AC minimum fan on time parameter
- See operator's manual for appropriate winter front usage

AIR INTAKE SYSTEM

The following are highlights of some of the more common or critical aspects of this system.

- The air intake screen may not be blocked, either fully or partially
- Modification to the air intake system may not restrict airflow. For example, pipe diameter may not be reduced
- All sensors must be retained in existing locations
- To retain system seal, proper clamp torque must be used. Refer to service manual for proper clamp torque

CHARGE AIR COOLER SYSTEM

The following are highlights of some of the more common or critical aspects of this system.

- The Charge Air Cooler may not be modified
- The installation of engine overspeed shutdown devices must not introduce restriction in the intake system
- All plumbing associated with the charge air cooler may not be modified

ELECTRICAL SYSTEM

The following are highlights of some of the more common or critical aspects of this system.

- Electrical harnesses providing battery power and electronic control signals to engine and emissions control devices/vehicle OBD components including datalinks may not be spliced. These emissions control devices/vehicle OBD components include the following:
 - throttle pedal
 - vehicle speed sensor
 - aftertreatment wiring
 - 9-pin OBD Connector
 - CAN Communication / OBD Diagnostic wiring
- If the alternator or battery is substituted, it must meet the requirements of the engine manufacturer's guidelines. This includes alternator ground voltage drop and alternator ground cable effectiveness. See the engine manufacturer's guidelines for recommended test procedure. Additionally the maximum voltage differential and the peak-peak voltage differential between the engine ECM block ground stud and battery negative terminal may not exceed 500 mV under any combination of loads or operating conditions.
- Only an OBD compliant battery disconnect switch may be installed on vehicles equipped with EPA 2013 and beyond compliant diesel engines. An OBD compliant switch and harness, even in the off position, supply a small amount of power to the engine controller and enable certain emissions critical functions (e.g. DEF line purge). Any modifications to the electrical system which interrupt this power supply will cause OBD fault codes and illumination of the MIL. In addition, such a modification will render the engine non-compliant with certain emission regulations. As a general rule of thumb, you can remove and replace a battery disconnect switch on a truck equipped with a battery disconnect switch at the factory. However, if a battery disconnect switch was not installed in the factory a significant harness modification is required before a battery disconnect switch can be added.
- Installation of aftermarket transfer-cases must address the vehicle speed sensor position. The standard position of the speed sensor is at the transmission tail shaft. When a transfer-case is added, it is best to relocate the sensor to the axle side output shaft of the transfer-case. This is typically accomplished by adding a tone wheel into the driveline yoke assembly.
- Wiring extensions for the aftertreatment wiring are available for relocating the DEF tank from your dealer via PACCAR Parts. For relocation of DEF tank, refer to the aftertreatment section of this manual.
- The OBD/Diagnostic connector port is located below the dash to the left of the steering wheel. This connector and its location may not be changed.
- **WARNING:** *When jump starting using a battery charger/booster, verify that the battery charger/booster is set to the same jump start voltage and amperage specifications as the vehicle electrical system and batteries (i.e. if the vehicle electrical system is a 12 volt system, the jump start voltage on the battery charger/booster shall be set at no higher than a 12 volt setting). Failure to comply may cause an explosion and/or fire resulting in death, personal injury, equipment or property damage.*



- See additional general wire routing statements on next page

GENERAL WIRE ROUTING

The following are highlights of some of the more common or critical aspects of this system.

- Whenever possible, battery cables, electrical wires, and wire harnesses should be secured by clamps attached to rigid components (for example, the engine, frame, bracket, etc.), or secured by tie straps fastened to other restrained lines at intervals not exceeding 460mm (18 in.).
- Battery cables, alternator cables, electrical wires, and wires harnesses routed on the chassis and engine should be covered by braided loom or convoluted tubing.
- At the clamping or tie points, battery cables, electrical wires, and wire harnesses should be covered by braided loom or convoluted tubing.

SAFETY RELATED COMPONENTS AND SYSTEMS

Upfitting and other modifications may change the compliance of an as-built vehicle. As such, Peterbilt will not support any modifications that affect the as-built compliance of a vehicle. These may include modifications to the following:

- Stability Control Systems – for vehicles with factory-installed Stability Control Systems, modifications to the following are not supported:
 - Wheelbase (reducing or increasing wheelbase)
 - Lift Axles (removal or addition)
 - Conversion of a truck to a tractor
- Factory installed Safety Systems (Factory installed Safety Systems will not be removed or inactivated)
- Green House Gas Requirements

SECTION 3 DIMENSIONS

INTRODUCTION

This section has been designed to provide enough information to successfully layout a chassis in the body planning process. All dimensions are inches unless otherwise noted. Optional equipment may not be depicted. Please contact your local Peterbilt dealer if more dimensional information is desired.

ABBREVIATIONS

Throughout this section and in other sections as well, abbreviations are used to describe certain characteristics on your vehicle. The chart below lists the abbreviated terms used.

TABLE 3-1. Abbreviations Used

AF	After Frame – Frame rail overhang behind rear axle(s)
CA	Cab to Axle – Dimension from back of the cab to the centerline of the rear axle(s)
WB	Wheelbase – Measured from front axle to the centerline of the rear axle(s)
FS	Front suspension height
RS	Rear suspension height
SLR	Tire Static Loaded Radius
SOC	Side of cab
BOC	Back of cab
UC	Under cab
BBC	Bumper to back of cab
BFA	Bumper to front axle
FAB	Front axle to back of cab
FDA	Front drive axle
FEPTO	Front engine PTO extension. Measured from the front of the grille to the front of the bumper
SH	Short aero hood (107")
MH	Medium aero hood (109")
VH	Vocational hood (109")

OVERALL DIMENSIONS

This section includes drawings and charts of the following Peterbilt Models: 535, 536, 537, & 548. Several optional configurations are also included.

On the pages that follow, detailed drawings show particular views of each vehicle. They illustrate important measurements critical to integrating bodies of all types. See the "Table of Contents" at the beginning of the manual to locate the drawing that you need.

All heights are given from the bottom of the frame rail.

Peterbilt also offers .dxf files and frame layouts of ordered chassis prior to build. Please speak with your local dealership to request this feature when specifying your chassis.

MODELS 535, 536, 537, & 548 – 107” BBC AERO HOOD

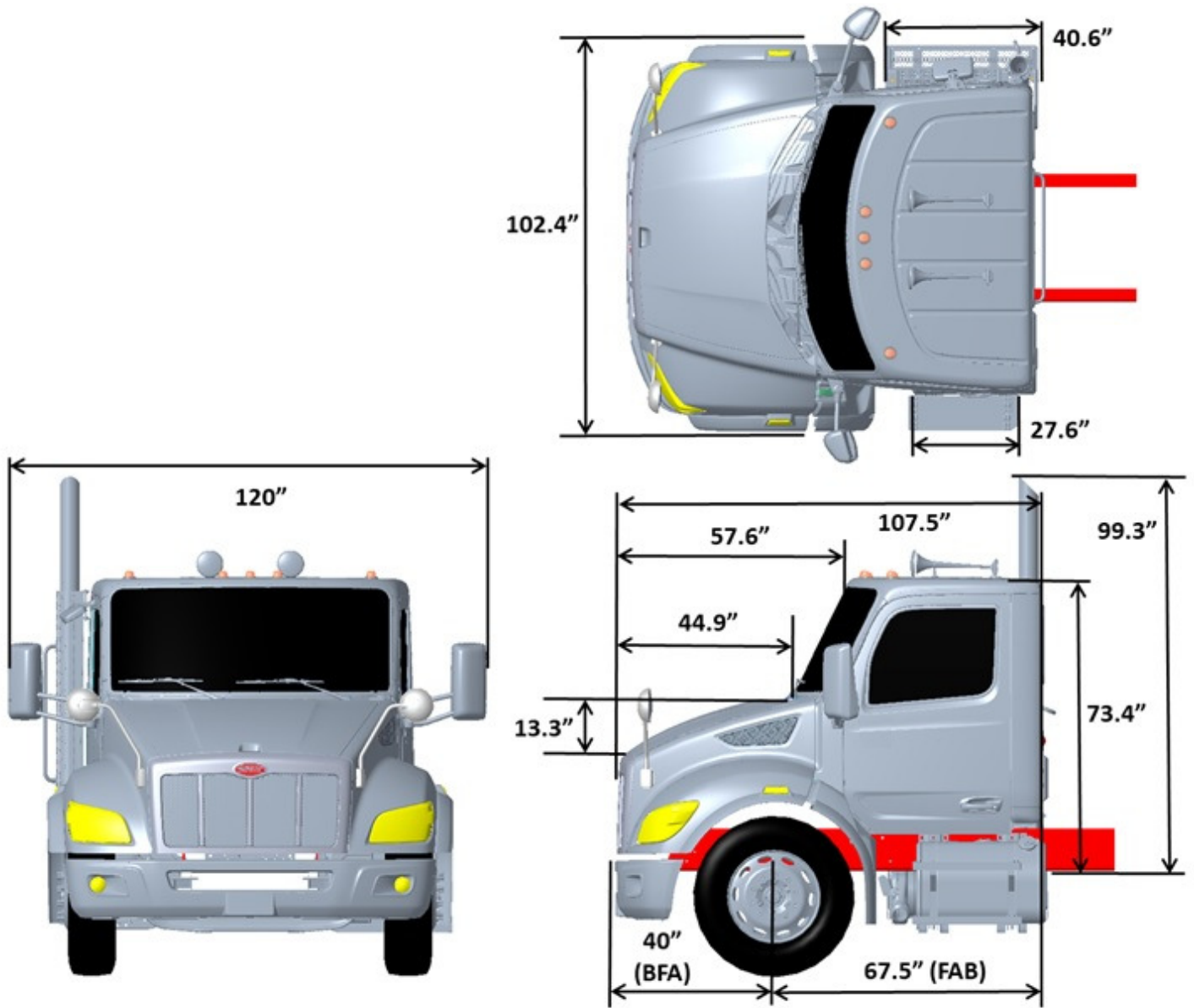

FIGURE 3-1. Short Aero Hood (107” BBC) Overall Dimensions

NOTES:

- 1) DIMENSIONS ARE FOR REFERENCE ONLY
- 2) DIMENSIONS REFERENCE FRONT OF BUMPER
- 3) DIMENSION FRONT AXLE TO FRONT OF FRAME (FFA) IS 26.8”
- 4) DIMENSION FRONT OF BUMPER TO FRONT OF FRAME (BFF) IS 13.2”
- 5) FLAT ROOF SHOWN, CURVED ROOF 4” TALLER
- 6) 36” EXHAUST STANDPIPE SHOWN, OTHER HEIGHT OPTIONS ARE AVAILABLE

MODELS 536, 537, & 548 – 109" BBC AERO HOOD

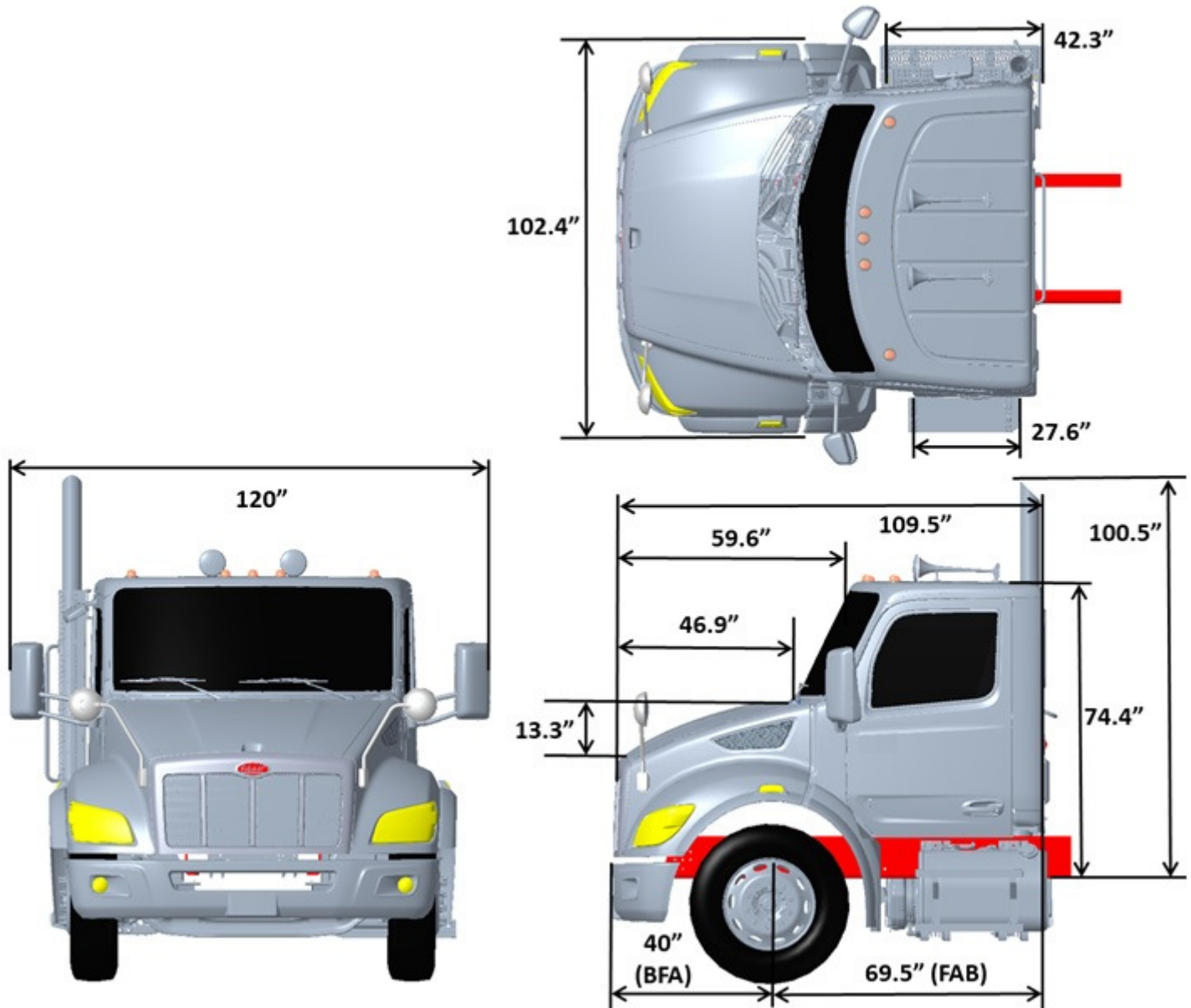

FIGURE 3-2. Medium Aero Hood (109" BBC) Overall Dimensions

NOTES:

- 1) DIMENSIONS ARE FOR REFERENCE ONLY
- 2) DIMENSIONS REFERENCE FRONT OF BUMPER
- 3) DIMENSION FRONT AXLE TO FRONT OF FRAME (FFA) IS 26.8"
- 4) DIMENSION FRONT OF BUMPER TO FRONT OF FRAME (BFF) IS 13.2"
- 5) FLAT ROOF SHOWN, CURVED ROOF 4" TALLER
- 6) 36" EXHAUST STANDPIPE SHOWN, OTHER HEIGHT OPTIONS ARE AVAILABLE

MODELS 537 & 548 – 109" VOC HOOD

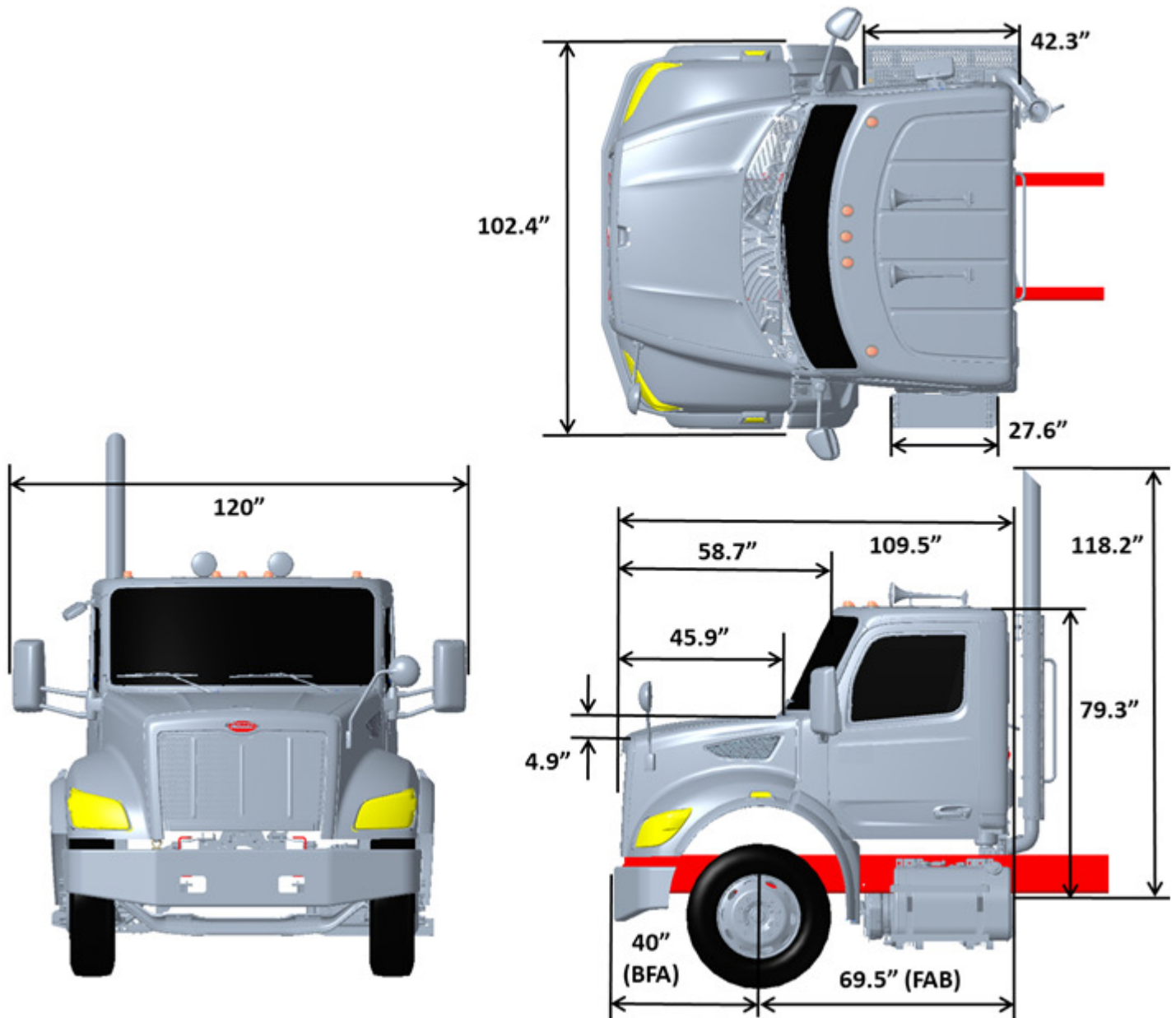

FIGURE 3-3. Vocational Hood (109" BBC) Overall Dimensions

NOTES:

- 1) DIMENSIONS ARE FOR REFERENCE ONLY
- 2) DIMENSIONS REFERENCE FRONT OF BUMPER
- 3) DIMENSION FRONT AXLE TO FRONT OF FRAME (FFA) IS 38.5"
- 4) DIMENSION FRONT OF BUMPER TO FRONT OF FRAME (BFF) IS 1.5"
- 5) FLAT ROOF SHOWN, CURVED ROOF 4" TALLER
- 6) 48" EXHAUST STANDPIPE SHOWN, OTHER HEIGHT OPTIONS ARE AVAILABLE

MODELS 537 & 548 – VOC HOOD W/ 24" FEPTO BUMPER EXTENSION

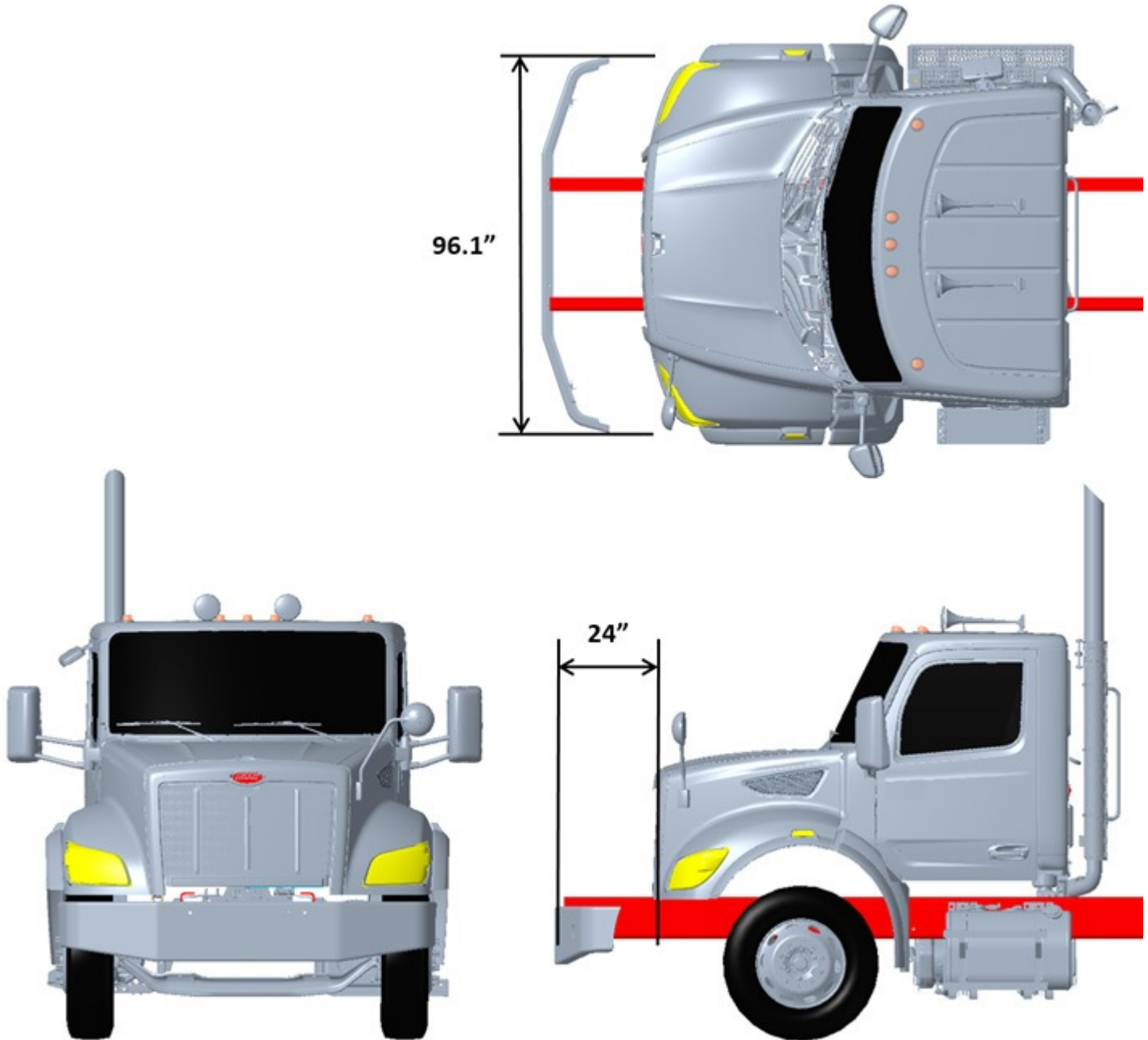

FIGURE 3-4. Vocational Hood 24" FEPTO Extension Top, Front & LH View – Overall Dimensions

NOTES:

- 1) DIMENSIONS ARE FOR REFERENCE ONLY
- 2) DIMENSIONS ARE TO FRONT OF BUMPER
- 3) DIMENSION FRONT OF BUMPER TO FRONT OF FRAME (BFF) IS 1.5"

CAB – 2.1m MEDIUM DUTY FAMILY

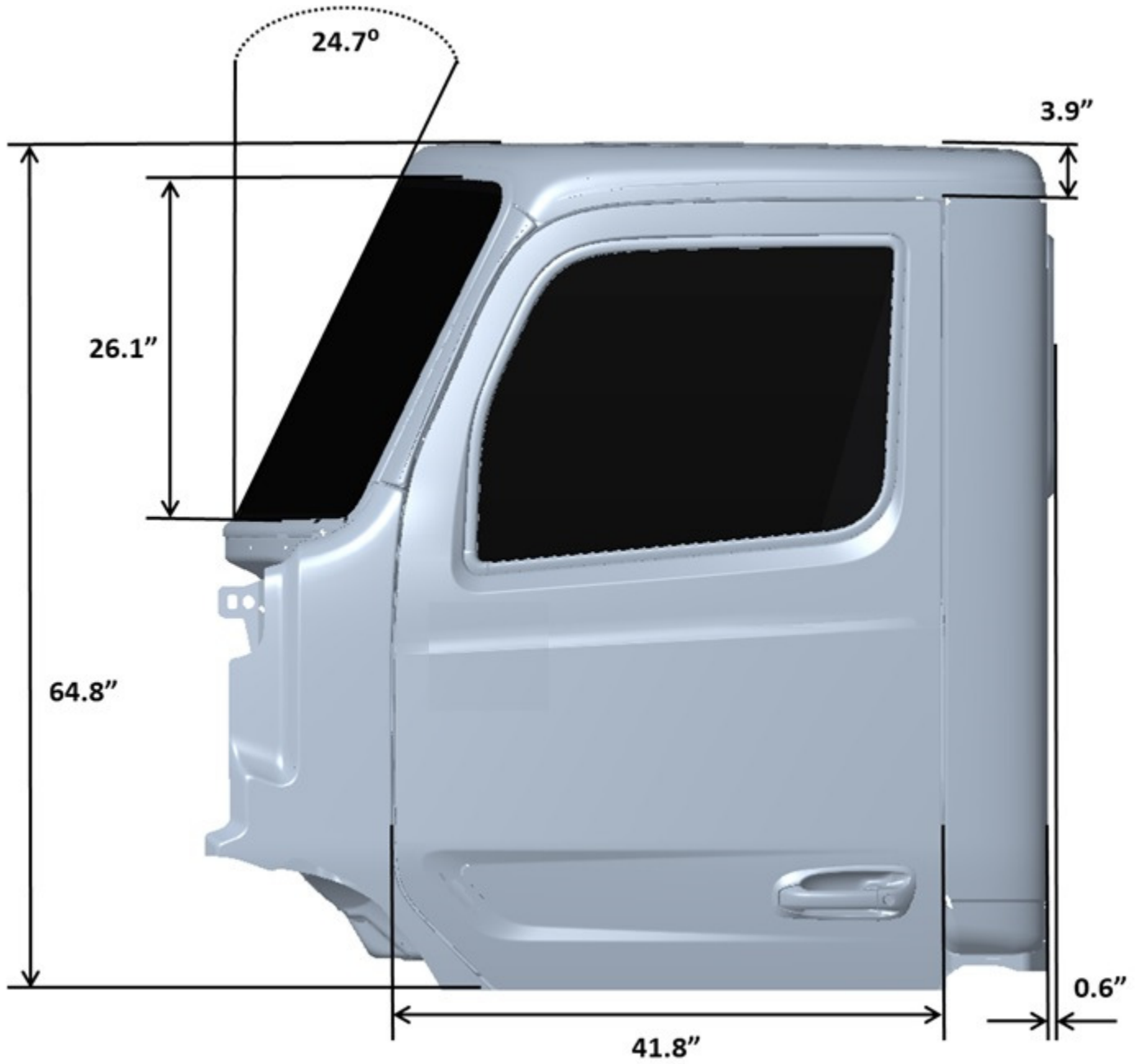

FIGURE 3-5. Cab Dimensions 2.1m Medium Duty

NOTE:

- 1) FLAT ROOF SHOWN, CURVED ROOF 4" TALLER

REAR WINDOW

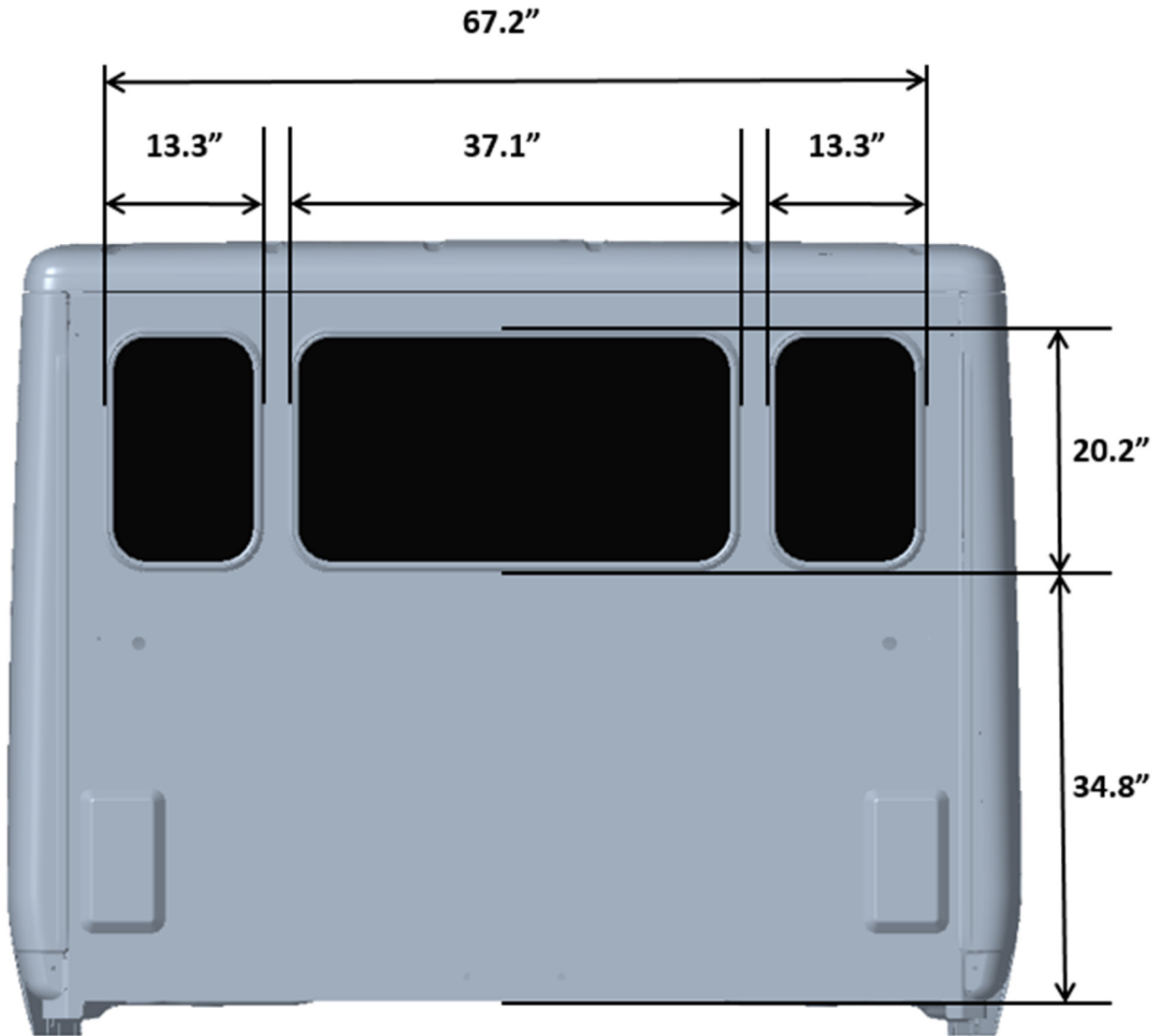

FIGURE 3-6. Rear Window Dimensions

CAB SUSPENSION

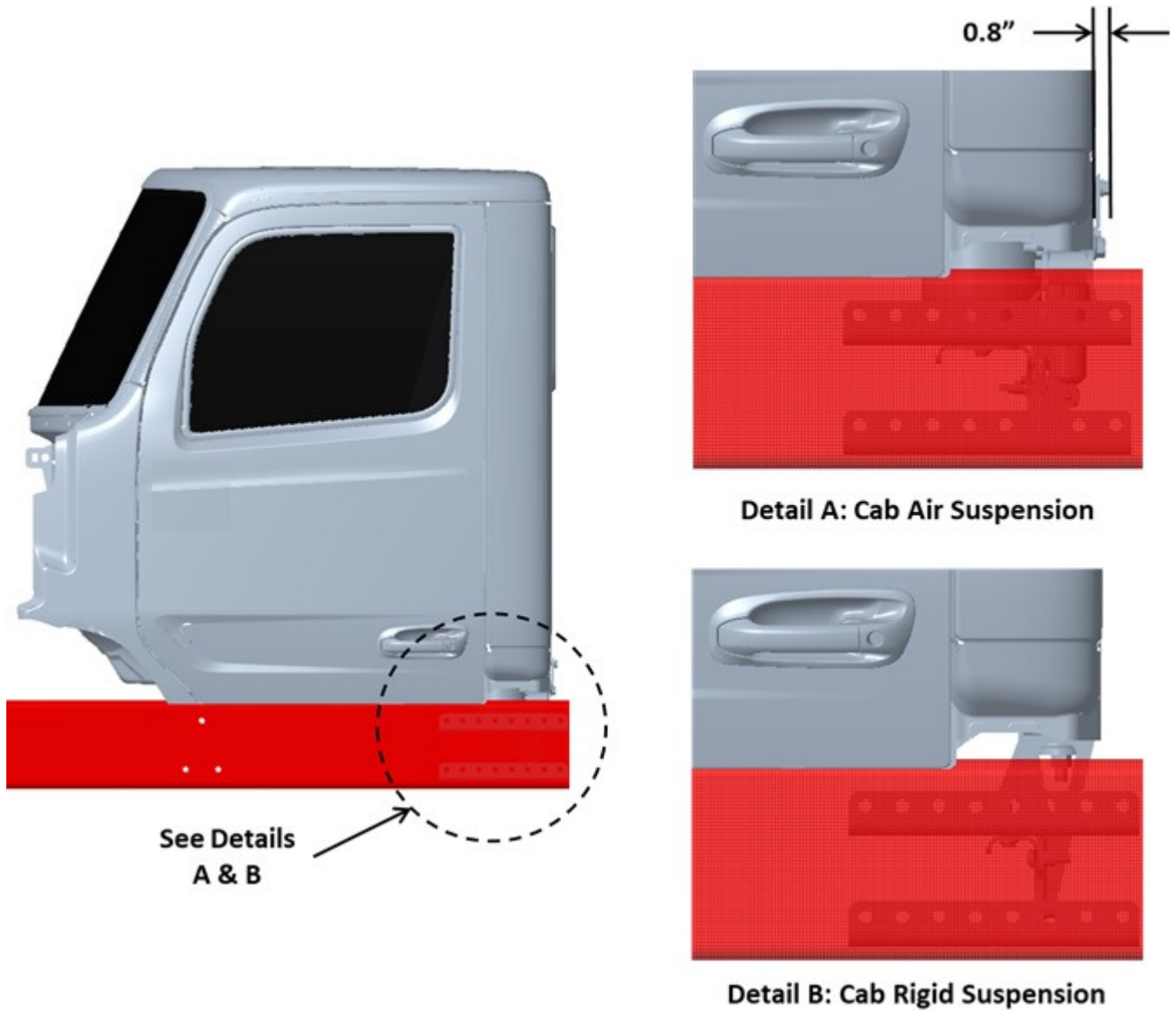

FIGURE 3-7. Cab Suspension Dimensions

Note:

- 1) Rigid Cab Suspension does not protrude BOC

CAB STEP HEIGHT

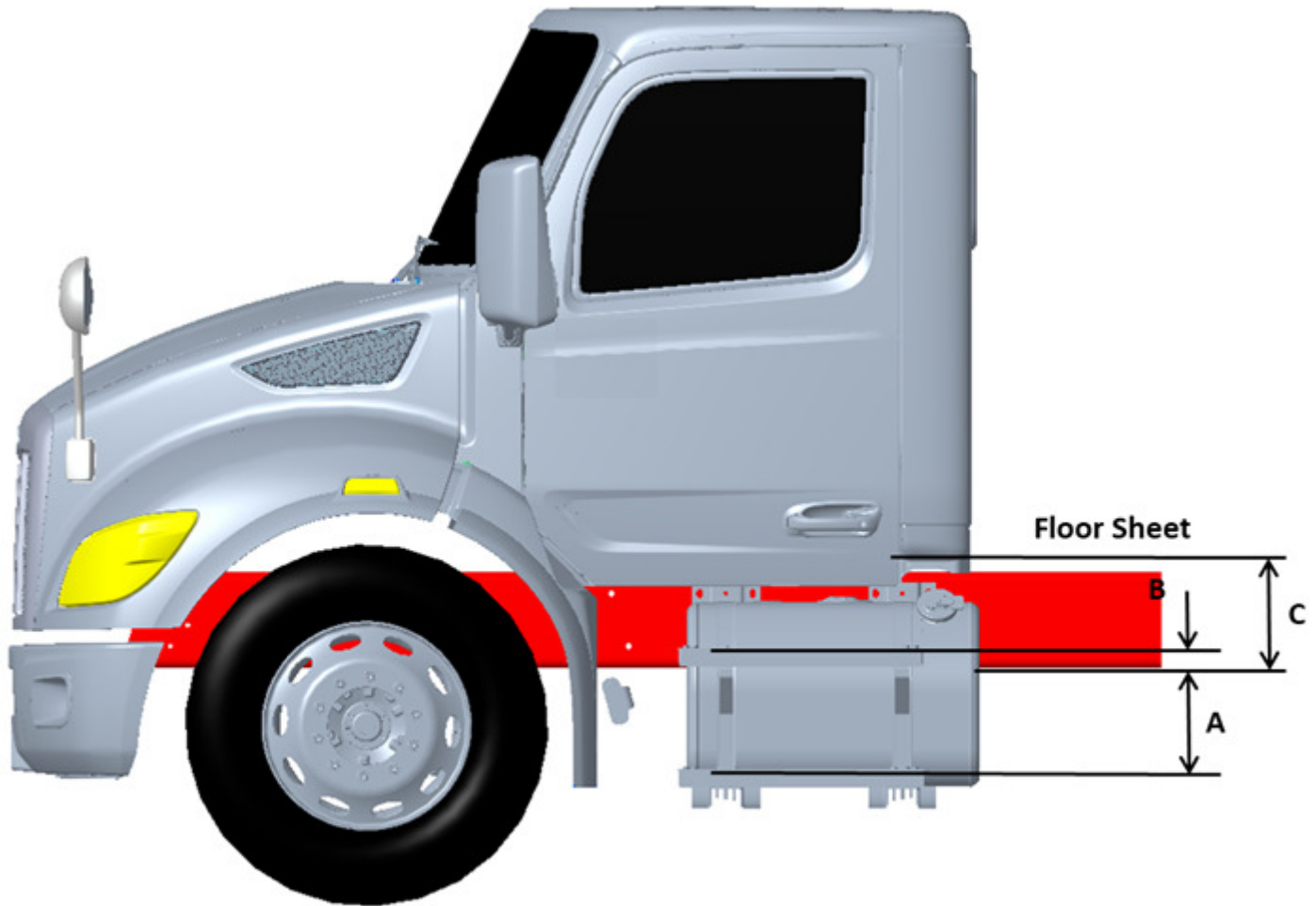

FIGURE 3-8. Cab Step Height Dimensions (Table 3-2)

Table 3-2. Cab Step Height

Description	A (First Step)	B (Second Step)	C (Cab Floor)
Battery Box	11.5"	1.8"	See Note 1
Fuel Tank	11.5"	1.8"	See Note 1
RH UCAB Aftertreatment Box	8"	5.8"	See Note 1

Notes:

- 1) Dimension C: SH = 15.0", MH = 16.1", VH = 20.8"
- 2) LH shown, RH Dimensions are equivalent
- 3) Aftertreatment box is RH UCAB only

FRAME RAILS

Frame rail configurations are shown below. Frame height, flange and structural values can be found in the Body Mounting Section.

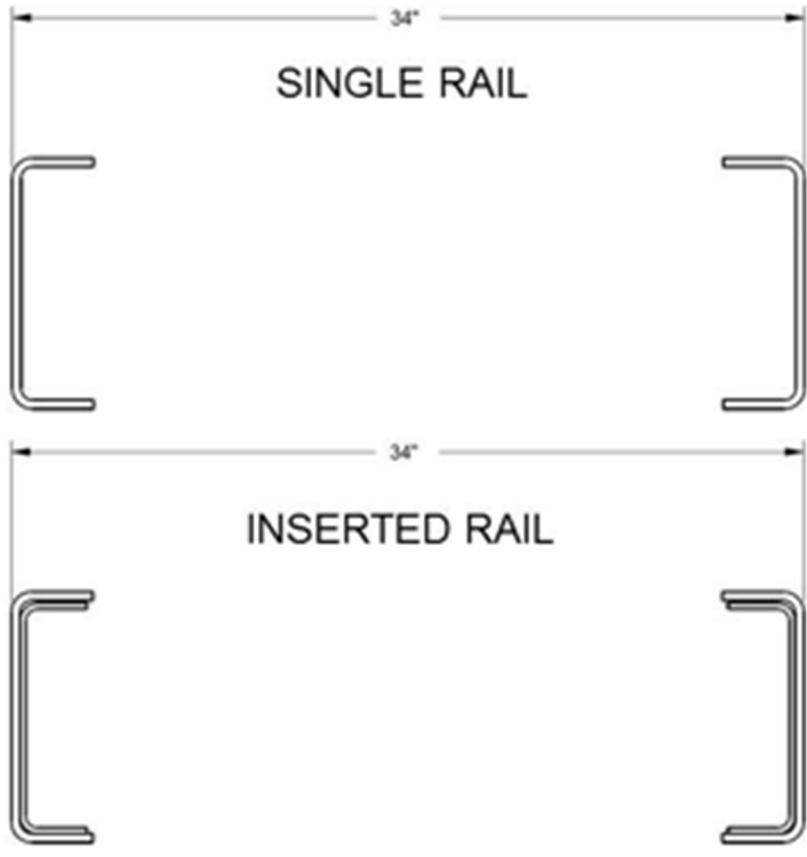

FIGURE 3-9. Frame Rail Configurations

FRAME HEIGHT CHARTS

THE FOLLOWING FRAME HEIGHT CHARTS MAY BE USED FOR FINDING APPROXIMATE FRONT AND REAR FRAME HEIGHTS.

THE RESULTS ARE APPROXIMATIONS BECAUSE OF THE MANY VARIABLES SUCH AS TIRE TREAD THICKNESS, MANUFACTURING TOLERANCES, SPRING SET, AND THE LOADING IMPOSED IN THE LOADED SITUATION.

LOADED VALUES ARE QUOTES FOR REPRESENTATIVE LOADS AT THE GROUND FOR THE PARTICULAR SPRING AND AXLE COMBINATION, AND, AS SUCH, CAN VARY WITH LOADING VARIATIONS.

SPECIAL INSTALLATIONS ARE SOMETIMES POSSIBLE WITH CERTAIN SUSPENSIONS ALLOWING VARIATIONS FROM STANDARD. PLEASE CONTACT APPLICATIONS ENGINEERING FOR INFORMATION.

FRONT FRAME HEIGHT

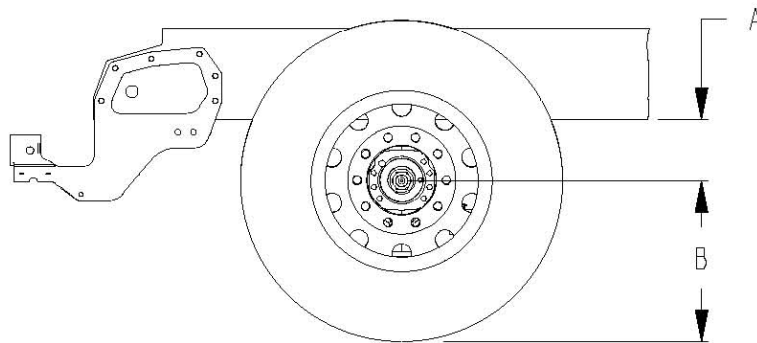

REAR FRAME HEIGHT

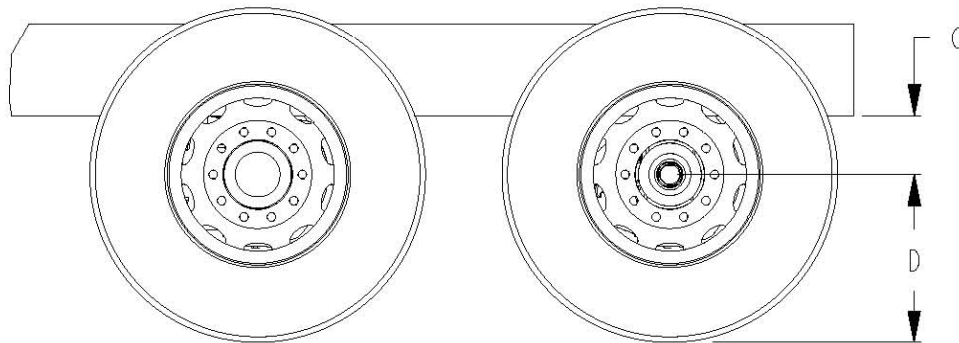

NOTES:

- 1) "B" AND "D" DIMENSIONS CAN BE FOUND IN THE TIRES/WHEELS SECTION OR IN THE TIRE VENDOR'S LITERATURE.

FIGURE 3-10. Frame Height

FRONT FRAME HEIGHTS "A"

TABLE 3-3. Front Frame Ride Height "A"

Front Suspension Rating (lbs)	Spacer Height (mm)	A (in)	
		Light	Loaded
8,000, 10,000 & 12,000	5	7.4	6.5
	30	8.4	7.5
	40	8.8	7.9
	50	9.2	8.3
	60	9.6	8.7
	70	10	9.1
	80	10.4	9.4
13,200	5	9.4	8.3
	30	10.4	9.3
	40	10.8	9.6
	50	11.2	10
	60	11.6	10.4
	70	12	10.8
	80	12.4	11.2
14,600	5	9.4	7.9
	30	10.4	8.9
	40	10.8	9.3
	50	11.2	9.7
	60	11.6	10.1
	70	12	10.5
	80	12.4	10.9
16,000	5	10	8.5
	30	10.9	9.5
	40	11.3	9.9
	50	11.7	10.3
	60	12.1	10.7
	70	12.5	11.1
	80	12.9	11.5
20,000	5	10	7.7
	30	10.9	8.7
	40	11.3	9.1
	50	11.7	9.4
	60	12.1	9.8
	70	12.5	10.2
	80	12.9	10.6

NOTES:

- 1) Spacers are used by Engineering to obtain a level frame and are not optional.
- 2) LIGHT or UNLADEN heights are calculated on the below assumptions
 - a. 12K or 14.6K springs assumes 8,000 lbs. load in LIGHT condition
 - b. 16K springs assumes 8,500 lbs. load in LIGHT condition
 - c. 18K - 20K springs assumes 9,000 lbs. load in LIGHT condition
- 3) "A" dimension shown is to bottom of frame rail. Add frame rail height dimension for frame height.
- 4) All suspension heights are with standard 3.5" drop axles.

REAR FRAME HEIGHTS "C"

TABLE 3-4. Single Drive Rear Suspension Height "C"

Suspension	Rating	Version	C (in)	
			Light Height	Laden Height
AIR TRAC	20,000 lbs.	Standard	11.4	11.0
	23,000 lbs.	Standard	11.4	11.0
AIR LEAF	18,000 lbs.	Standard	7.0	7.0
TAPER LEAF	13,500 lbs.	Standard	9.4	7.4
	18,000 lbs.	Standard	8.9	7.0
REYCO 79KB	20,000 lbs.	Taperleaf (3.38" saddle)	9.4	11.8
	21,000 lbs.	Taperleaf (1.38" saddle)	7.4	9.8
	23,000 lbs.	Multileaf (1.38" saddle)	8.8	11.6
	26,000 lbs.	Multileaf (1.38" saddle)	9.2	11.8
	28,000 lbs.	Multileaf (1.38" saddle)	9.7	12.3
	31,000 lbs.	Multileaf (1.38" saddle)	10.8	13.3
REYCO 102	23K-29K lbs.	4.38 saddle	12.1	10.2
	23K-29K lbs.	4.63 saddle	12.2	10.4
	29,000 lbs.	3.50 saddle	11.7	10.0
	31,000 lbs.	3.50 saddle	12.2	10.5
	31,000 lbs.	4.38 saddle	12.5	10.7
	31,000 lbs.	4.63 saddle	12.7	10.9
REYCO 102AR (AIR)	17K -23K	Standard	9.3	9.3
		Low	8.3	8.3

TABLE 3-5. Tandem Rear Suspension Height “C”

Suspension	Rating	Version	C (in)	
			Light Height	Laden Height
AIR LEAF	38,000 lbs.	Standard	12.0	11.7
LOW AIR LEAF	40,000 lbs.	Standard	8.8	8.5
FLEX AIR	38,000 lbs.	Standard	8.7	8.5
LOW LOW AIR LEAF	40,000 lbs.	Standard	6.8	6.5
AIR TRAC	40K-46K lbs.	Standard	11.4	11.0
NEWAY ADZ	46K lbs.	Standard	10.0	10.0
REYCO 102 MULTILEAF	40,000 lbs.	1.75 saddle (STD)	11.7	9.9
		1.38 saddle	10.2	8.3
		3.38 saddle	13.4	11.5
	44,000 lbs.	1.75 saddle (STD)	11.7	9.8
		1.38 saddle	11.5	9.7
CHALMERS 854 ¹	40,000 lbs.	LOW	11.2	8.9
		HIGH	12.4	10.2
		X-HIGH	14.5	12.2
		XX-HIGH	17.2	14.9
CHALMERS 854 ¹	46,000 lbs.	LOW	11.3	8.9
		HIGH	12.5	10.1
		X-HIGH	14.7	12.2
		XX-HIGH	17.3	14.9
RT-403	40,000 lbs.	6.00 saddle	9.9	8.9
		7.19 saddle (std.)	11.2	10.1
HMX EX	40,000 lbs.	16.5	11.6	9.5
		17.5	12.6	10.5
		18.5	13.6	11.5
	46,000 lbs.	16.5	11.6	9.5
		17.5	12.6	10.5
		18.5	13.6	11.5
RS-463	46,000 lbs.	12.25 saddle	9.7	8.9
		14.00 saddle (std.)	11.5	10.6
		15.25 saddle	12.7	11.9
RT-463	46,000 lbs.	6.00 saddle	11.3	10.5
		7.2 saddle (std.)	13.0	11.4
		11.00 saddle	16.3	15.2

NOTES:

1) Laden dimension shown with standard restrictor cans. Add 0.7” for #29 High Stability Restrictor Cans.

FRAME MOUNTED COMPONENT GROUND CLEARANCE

To calculate estimated ground clearance for frame mounted components, using the underside of the frame rail as a reference, do the following:

- 1) Find the front and rear tire SLR data from the manufacturer’s literature, as described on page 3-11
- 2) Determine front and rear suspension ride heights from the tables on the previous few pages
- 3) Add the tire’s SLR to its respective suspension ride height to calculate frame height
- 4) Find the bottom of rail to bottom of component dimension “Y” for the desired component in table 3-6 below.
- 5) Ground clearance = lowest frame height – component dimension “Y”



TABLE 3-6. Bottom of Frame to Bottom of Component Dimension “Y”

Component	Y (in)
Fuel Tank (All)	15.8
Battery/Tool Box (All)	13.4
RHUC DPF/SCR	15.3
RHUC Natural Gas Catalyst	18.1
Under Frame DPF/SCR	15.2
Under Frame Catalyst B6.7N	15.6
Under Frame Catalyst L9N	16.6
Small/Large DEF Tank	15.0

Ground clearances, like height calculations, are affected by numerous factors including, but not limited to, front and rear axle loading and tire pressure. Placement of frame components, such as fuel tanks, will affect loads on the front axle and rear axle, as well as distribution to the left and right side of the vehicle. Ground clearances calculated from this information are estimates only.

FRAME SPACE REQUIREMENTS

To ensure adequate space for fuel tanks, ladder steps, additional tool/battery boxes, pusher axles and other frame mounted components; the amount of available space must be calculated by using the formula below. Contact Applications Engineering for configurations not shown in this section. Examples are shown at the end of this section.

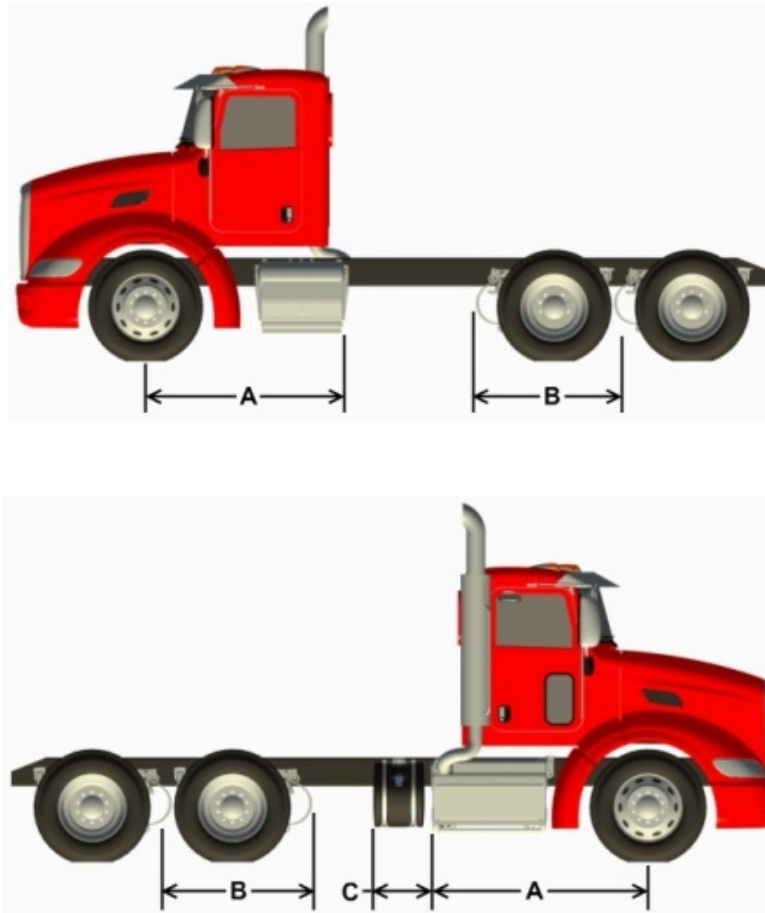

FIGURE 3-11. Frame Space

BASIC FORMULA: BOC Frame Space = Wheelbase - Dimension A - Dimension C - Dimension B

Dimension "A" (shown in charts on following pages) is the minimum clearance measured from the centerline of the front axle to the back of the under cab component (DPF/SCR exhaust, fuel tank, battery box, tool box, etc.). Dimension "C" is the amount of space from the rear of the under cab component to the back of the DEF tank (can be on LH or RH rail). Dimension "B" is the amount of required suspension and quarter fender clearance from the rear axle centerline to clear rail for a given suspension.

FRAME SPACE DIMENSION "B"

TABLE 3-7. Rear Suspension Dimension "B"

REAR SUSPENSION (52" Axle Spacing on Tandems)	B (in)	OVERHANG (1)	NOTES
AIR LEAF SINGLE (18K)	32.2	23.5	2
AIR LEAF TANDEM	53	53	2
LOW/LOW LOW AIR LEAF	62.4	53	
LOW AIR LEAF SINGLE	36.5	27	
AIR TRAC SINGLE	27	27	3
AIR TRAC TANDEM	53	53	3
TAPER LEAF SINGLE (13.2/18K)	32.2	34.1	
FLEX AIR	59	53.7	7
CHALMERS 800 (54" SPACING)	49	52	4
HENDRICKSON HLM / AL	26.6	N/A	6
HENDRICKSON HLR2	30.5	N/A	6
HENDRICKSON HMX, HN	53	54	
HENDRICKSON R/RS/RT/RTE	53	53	3
HENDRICKSON SC20	25.6	15	6
HENDRICKSON SC8/10/13, FX, FXO, SCO	23.6	13.8	5, 6
NEWAY ADZ (54" SPACING)	61	58.3	
REYCO 102 SINGLE	30	25.8	
REYCO 102AR SINGLE	30	31	
REYCO 102 TANDEM	56	52.7	
REYCO 79KB	30.1	32.2	
WATSON-CHALIN AL2200	26.6	22.2	6
WATSON-CHALIN SL0893SSR	27.6	11.8	5, 6
WATSON-CHALIN SL1093SSR	27.6	11.8	6
WATSON-CHALIN SL1190SSR	26	12.8	6
WATSON-CHALIN SL2065	27.6	14.4	6

NOTES:

- 1) Overhang for Tractor Taper EOF and Standard Mud flap Hangers on Suspensions; Square EOF w/o Crossmember for Lift Axles.
- 2) Add 2.0" to "B" dimension with quarter fenders.
- 3) Add 1.5" to "B" dimension with quarter fenders.
- 4) Add 0.6" to "B" dimension with quarter fenders.
- 5) Add 2.8" to "B" dimension with quarter fenders.
- 6) "B" dimension is from axle centerline (or bogie for tandem) to clear frame forward.
- 7) Extended Tractor Taper requires 58.0" overhang.

FRAME SPACE DIMENSION “A”

TABLE 3-8. LH Under Cab DEF Dimension “A”

Hood	A (in)
SH	33.9
MH/VH	35.8

TABLE 3-9. Under Cab Battery/Tool Box Dimension “A”

Rail	Hood	UC Component	A (in)
LH/RH	SH	3 battery/tool box	61.0
	SH	4 battery box	64.8
	MH/VH	3 battery/tool box	63.0
	MH/VH	4 battery box	64.8

TABLE 3-10. Under Cab DPF/SCR Dimension “A”

Hood	Engine Horsepower	A (in)
SH	LHP (PX-7 < 275hp)	68.9
	MHP (PX-7 > 275hp OR PX-9 < 365hp)	70.7
MH/VH	LHP (PX-7 < 275hp)	70.0
	MHP (PX-7 > 275hp OR PX-9 < 365hp)	71.6
	HHP (PX-9 > 365hp)	75.4

TABLE 3-11. Under Cab Fuel Tank Dimension "A"

RAIL	HOOD	DEF TANK LOC	DEF TANK SIZE	UC FUEL TANK	A (in)
LH	SH	LHUC	SMALL	50 GAL	68.4
				60 GAL	74.8
				70 GAL	81.2
				80 GAL	87.6
				100 GAL	N/A
	MH/VH			50 GAL	70.4
				60 GAL	76.8
				70 GAL	83.2
				80 GAL	89.6
				100 GAL	N/A
All	BOC	SMALL OR LARGE	50 GAL	68.4	
			60 GAL	72	
			70 GAL	78.5	
			80 GAL	84.8	
			100 GAL	97.6	
RH	SH	BOC OR LHUC	SMALL OR LARGE	50 GAL	68.4
				60 GAL	72
				70 GAL	78.5
				80 GAL	84.8
				100 GAL	97.6
	MH/VH			50 GAL	68.4
				60 GAL	72
				70 GAL	81.8
				80 GAL	84.8
				100 GAL	97.6

FRAME SPACE DIMENSION “C”

TABLE 3-12. BOC DEF Dimension “C”

Rail	Hood	UC Component	DEF Tank size	C (in)
LH	All	50 gal fuel	Small	9.2
		60 gal fuel		9.5
		70 gal fuel		9.0
		80 gal fuel		8.5
		3 battery box		20.5
		4 battery/tool box		20.6
RH	SH	LHP DPF/SCR		18.9
	MH/VH	LHP DPF/SCR		17.9
	SH	MHP DPF/SCR		19.1
	MH/VH	MHP DPF/SCR		18.2
	All	HHP DPF/SCR		18.4
LH	All	50 gal fuel	Large	17.3
		60 gal fuel		17.6
		70 gal fuel		17.1
		80 gal fuel		16.6
		3 battery box		28.7
		4 battery/tool box		28.8
RH	SH	LHP DPF/SCR		22.9
	MH/VH	LHP DPF/SCR		22.0
	SH	MHP DPF/SCR		23.2
	MH/VH	MHP DPF/SCR		22.2
	All	HHP DPF/SCR		20.5

TABLE 3-13. BOC Battery/Tool Box Dimension “C”

Rail	Hood	UC Component	BOC Box	C (in)
LH/RH	All	All	Battery Box	29.9
			Tool Box	

TABLE 3-14. BOC Fuel Tank Dimension "C"

RAIL	HOOD	DEF TANK SIZE	UC COMPONENT	FUEL TANK SIZE	DEF TANK LOC	C (in)
LH	ALL	SMALL	3 BATT/TOOL BOX	50	LH BOC	55.6
					RH BOC	46.2
				60	LH BOC	62.0
					RH BOC	52.6
				70	LH BOC	68.4
					RH BOC	59.0
			80	LH BOC	74.8	
				RH BOC	65.4	
			100	LH BOC	N/A	
				RH BOC	N/A	
			4 BATT/TOOL BOX	50	LH BOC	57.6
					RH BOC	46.2
		60		LH BOC	64.0	
				RH BOC	52.6	
		70		LH BOC	70.5	
				RH BOC	59.0	
		80	LH BOC	76.8		
			RH BOC	65.4		
		100	LH BOC	N/A		
			RH BOC	N/A		
		LARGE	3 BATT/TOOL BOX	50	LH BOC	63.5
					RH BOC	46.2
				60	LH BOC	69.9
					RH BOC	52.6
70	LH BOC			76.3		
	RH BOC			59.0		
80	LH BOC		82.7			
	RH BOC		65.4			
100	LH BOC		95.5			
	RH BOC		77.1			
4 BATT/TOOL BOX	50		LH BOC	63.6		
			RH BOC	46.2		
	60	LH BOC	70.0			
		RH BOC	52.6			
	70	LH BOC	76.4			
		RH BOC	59.0			
80	LH BOC	82.7				
	RH BOC	65.4				
100	LH BOC	95.5				
	RH BOC	78.2				

TABLE 3-14. BOC Fuel Tank Dimension "C" Continued...

RAIL	HOOD	DEF TANK SIZE	UC COMPONENT	FUEL TANK SIZE	DEF TANK LOC	C (in)	
RH	ALL	SMALL	LHP DPF	50	LH BOC	34.6	
					RH BOC	34.9	
				60	LH BOC	41.0	
					RH BOC	41.3	
				70	LH BOC	47.4	
					RH BOC	47.8	
				80	LH BOC	53.8	
					RH BOC	93.5	
				100	LH BOC	66.6	
					RH BOC	106.3	
				MHP DPF	50	LH BOC	34.6
						RH BOC	74.6
			60		LH BOC	41.0	
					RH BOC	81.0	
			70		LH BOC	47.4	
					RH BOC	87.4	
			80		LH BOC	53.8	
					RH BOC	93.8	
			100		LH BOC	66.6	
					RH BOC	106.6	
			HHP DPF		50	LH BOC	34.6
						RH BOC	72.9
				60	LH BOC	41.0	
					RH BOC	79.3	
70	LH BOC	47.4					
	RH BOC	85.7					
80	LH BOC	53.8					
	RH BOC	92.0					
100	LH BOC	66.6					
	RH BOC	104.8					

TABLE 3-14. BOC Fuel Tank Dimension "C" Continued...

RAIL	HOOD	DEF TANK SIZE	UC COMPONENT	FUEL TANK SIZE	DEF TANK LOC	C (in)
RH	ALL	LARGE	LHP DPF	50	LH BOC	34.6
					RH BOC	82.2
				60	LH BOC	41.0
					RH BOC	88.6
				70	LH BOC	47.4
					RH BOC	95.0
			80	LH BOC	53.8	
				RH BOC	101.4	
			100	LH BOC	66.6	
				RH BOC	114.2	
			MHP DPF	50	LH BOC	34.6
					RH BOC	82.5
				60	LH BOC	41.0
					RH BOC	88.9
				70	LH BOC	47.4
					RH BOC	95.3
			80	LH BOC	53.8	
				RH BOC	101.7	
			100	LH BOC	66.6	
				RH BOC	114.5	
			HHP DPF	50	LH BOC	34.6
					RH BOC	80.7
				60	LH BOC	41.0
					RH BOC	87.1
70	LH BOC	47.4				
	RH BOC	93.5				
80	LH BOC	53.8				
	RH BOC	99.9				
100	LH BOC	66.6				
	RH BOC	112.7				

2021 MD EXHAUST CONFIGURATIONS

EXHAUST RH SOC - DPF/SCR RH UNDER CAB
 (Reference option code 3365270)

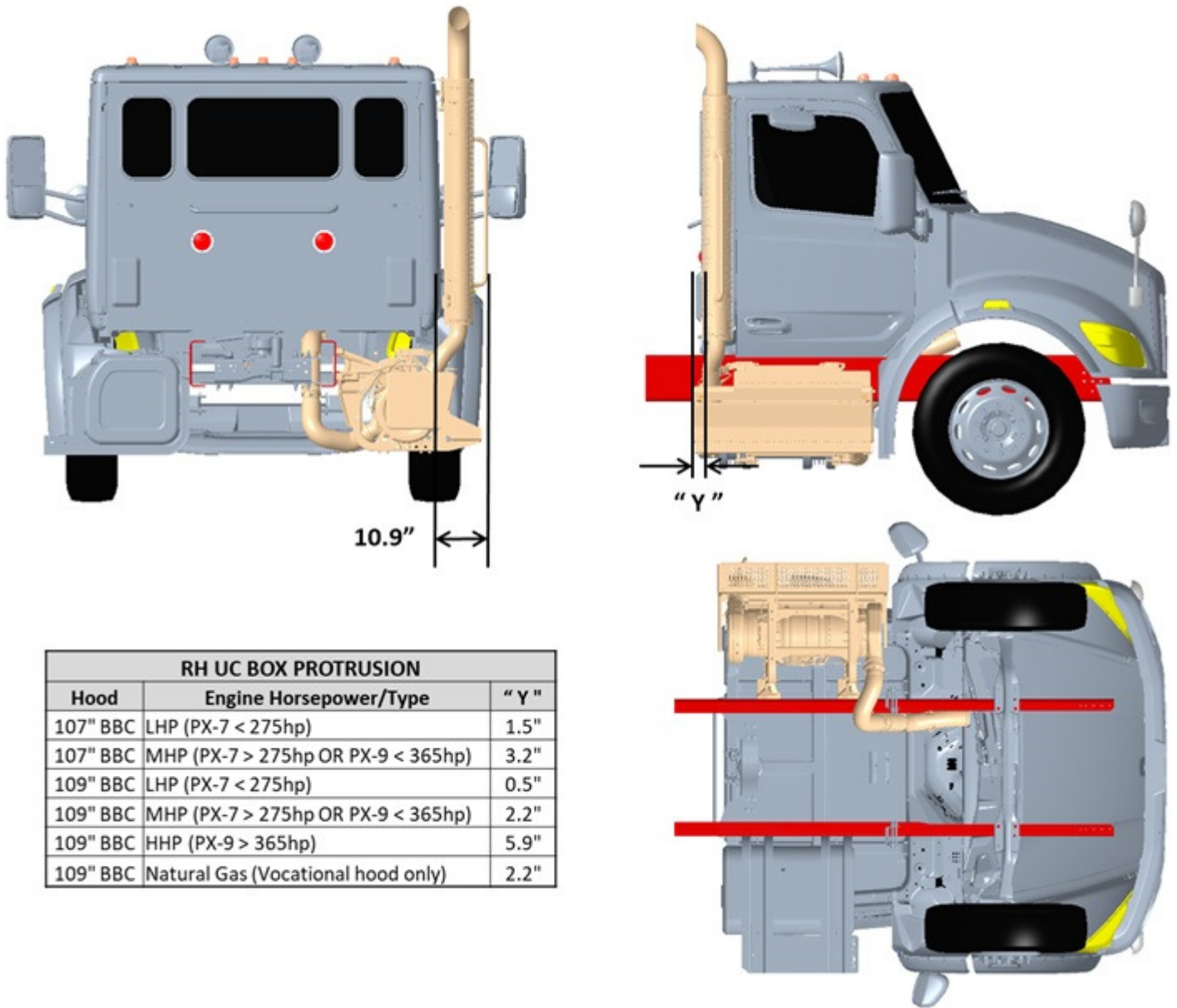

RH UC BOX PROTRUSION		
Hood	Engine Horsepower/Type	" Y "
107" BBC	LHP (PX-7 < 275hp)	1.5"
107" BBC	MHP (PX-7 > 275hp OR PX-9 < 365hp)	3.2"
109" BBC	LHP (PX-7 < 275hp)	0.5"
109" BBC	MHP (PX-7 > 275hp OR PX-9 < 365hp)	2.2"
109" BBC	HHP (PX-9 > 365hp)	5.9"
109" BBC	Natural Gas (Vocational hood only)	2.2"

FIGURE 3-12. Exhaust RH Side of Cab DPF/SCR RH under Cab

DIMENSIONS

3

EXHAUST RH BOC - DPF/SCR RH UNDER CAB

(Reference option code 3365250)

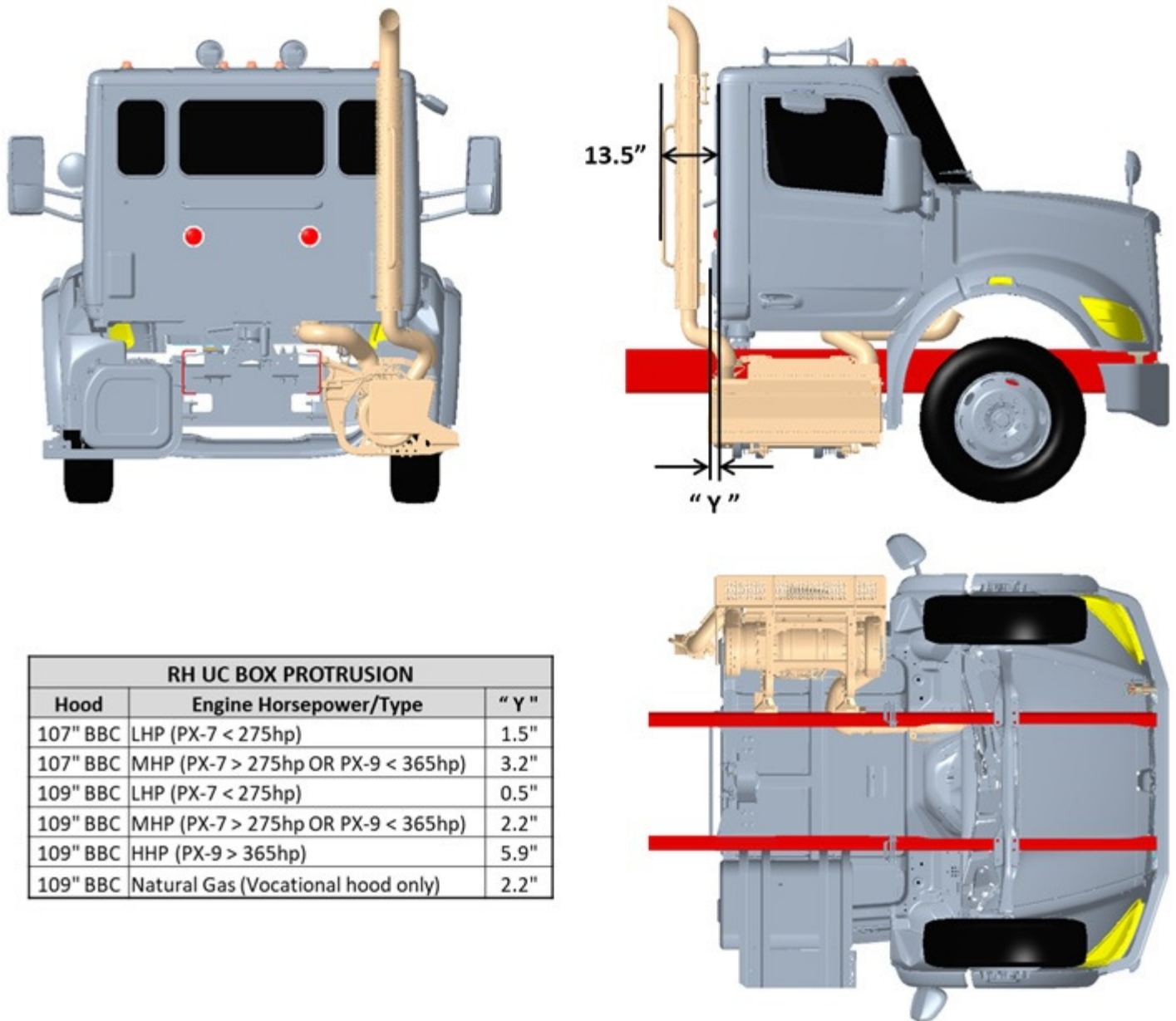

RH UC BOX PROTRUSION		
Hood	Engine Horsepower/Type	" Y "
107" BBC	LHP (PX-7 < 275hp)	1.5"
107" BBC	MHP (PX-7 > 275hp OR PX-9 < 365hp)	3.2"
109" BBC	LHP (PX-7 < 275hp)	0.5"
109" BBC	MHP (PX-7 > 275hp OR PX-9 < 365hp)	2.2"
109" BBC	HHP (PX-9 > 365hp)	5.9"
109" BBC	Natural Gas (Vocational hood only)	2.2"

FIGURE 3-13. Exhaust RH Back of Cab DPF/SCR RH under Cab

NOTES:

- 1) BOC exhaust only available with vocational hood.

EXHAUST RH HORIZONTAL - DPF/SCR RH UNDER CAB (STANDARD)

(Reference option code 3365280)

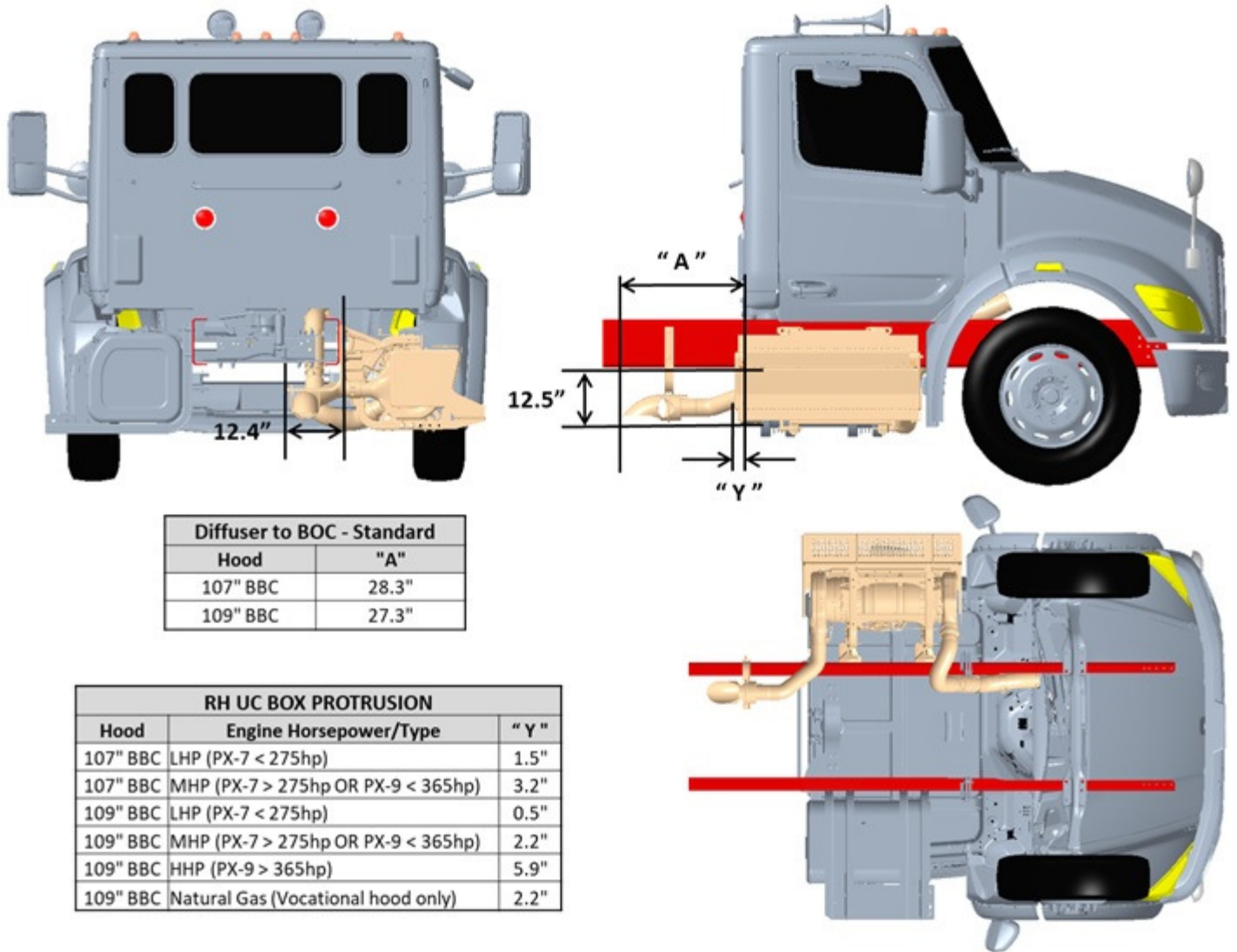

FIGURE 3-14. Exhaust RH Horizontal DPF/SCR RH under Cab (Standard)

DIMENSIONS

3

EXHAUST RH HORIZONTAL - DPF/SCR RH UNDER CAB (W/ RH DEF)

(Reference option code 3365280)

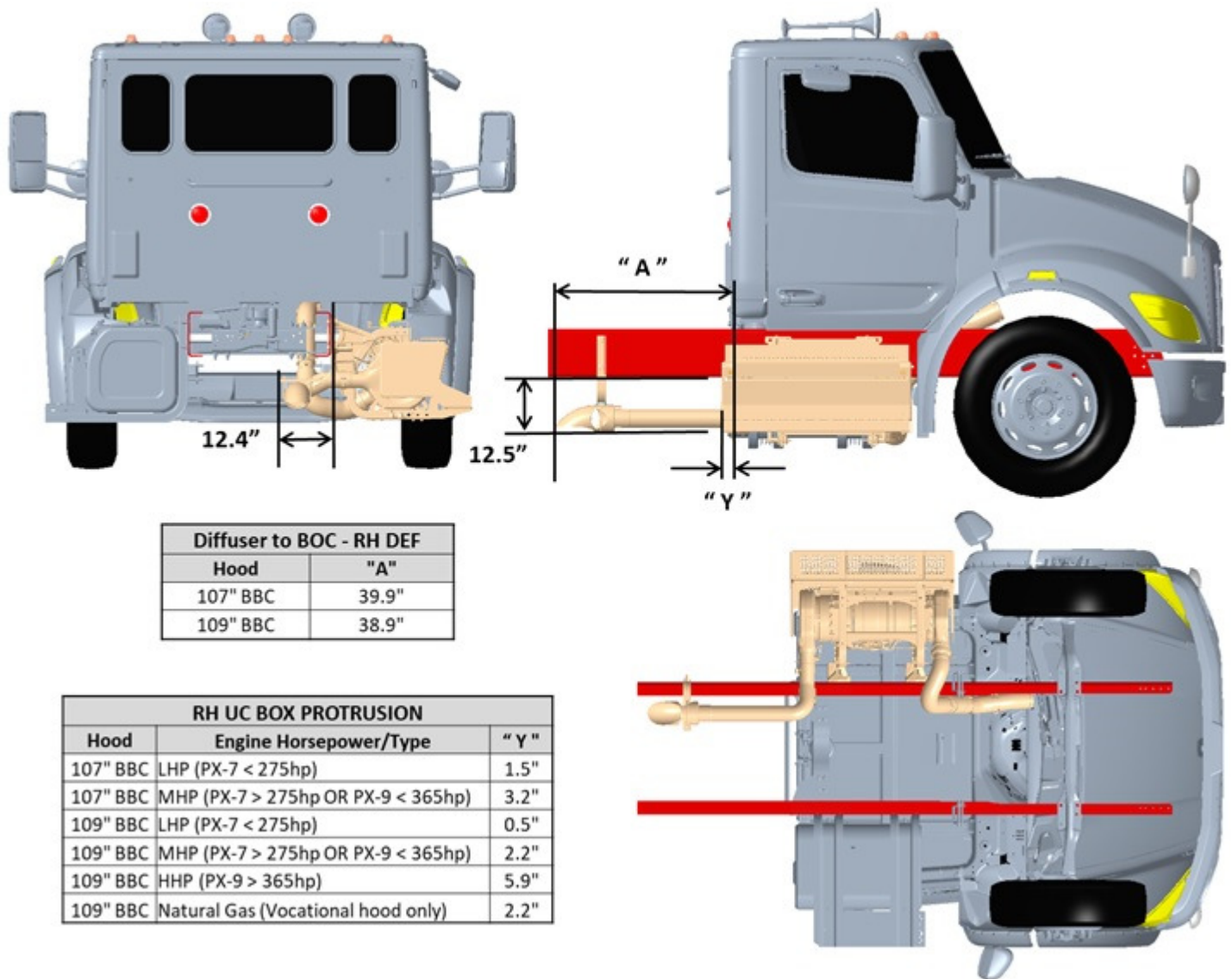

FIGURE 3-15. Exhaust RH Horizontal DPF/SCR RH under Cab (RH DEF)

DIMENSIONS

3

EXHAUST RH HORIZONTAL - DPF/SCR RH UNDER CAB (W/ FDA)

(Reference option code 3365280)

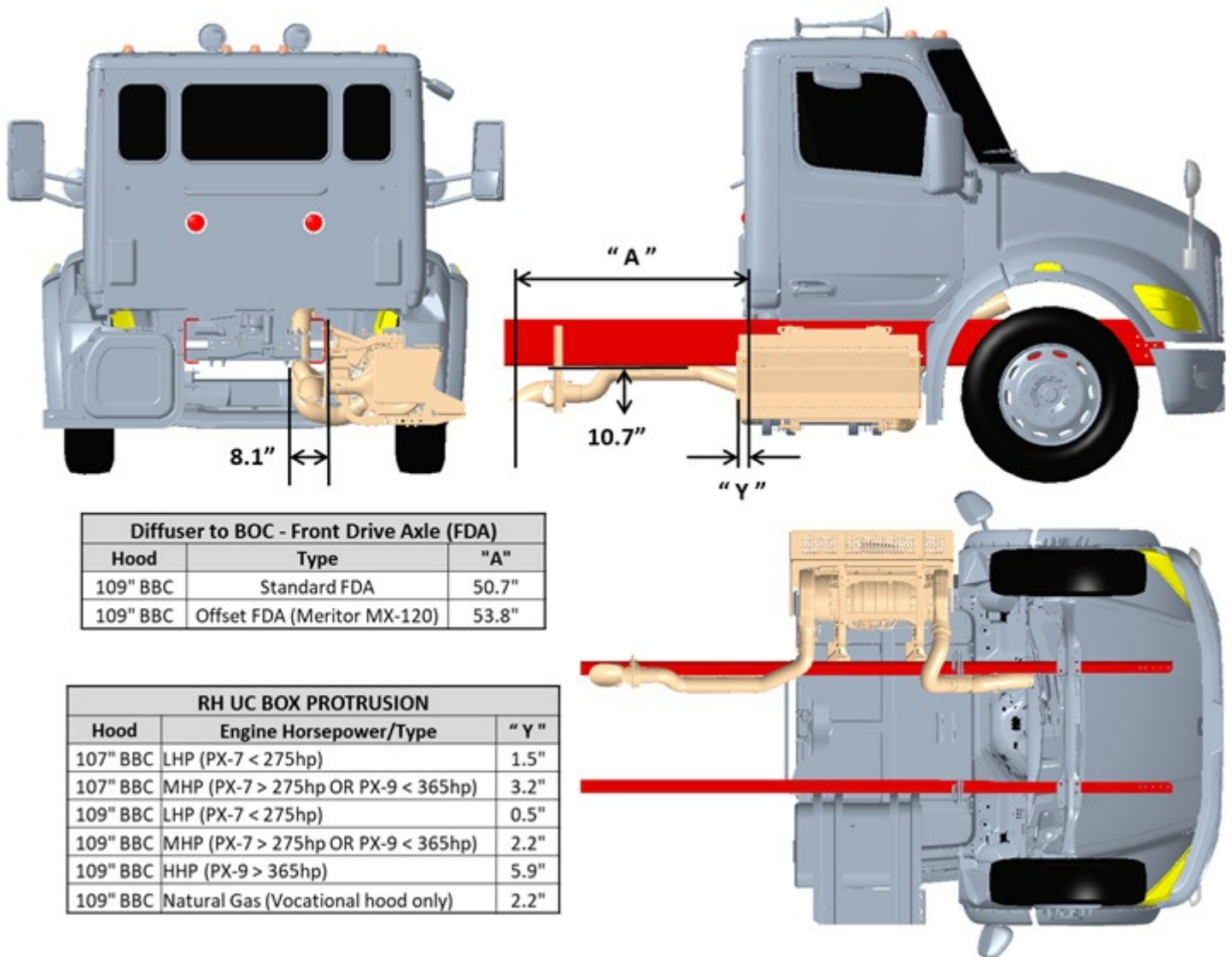

Diffuser to BOC - Front Drive Axle (FDA)		
Hood	Type	"A"
109" BBC	Standard FDA	50.7"
109" BBC	Offset FDA (Meritor MX-120)	53.8"

RH UC BOX PROTRUSION		
Hood	Engine Horsepower/Type	"Y"
107" BBC	LHP (PX-7 < 275hp)	1.5"
107" BBC	MHP (PX-7 > 275hp OR PX-9 < 365hp)	3.2"
109" BBC	LHP (PX-7 < 275hp)	0.5"
109" BBC	MHP (PX-7 > 275hp OR PX-9 < 365hp)	2.2"
109" BBC	HHP (PX-9 > 365hp)	5.9"
109" BBC	Natural Gas (Vocational hood only)	2.2"

FIGURE 3-16. Exhaust RH Horizontal DPF/SCR RH under Cab (FDA)

EXHAUST RH HORIZONTAL - DPF/SCR RH UNDER FRAME

(Reference option code 3365290)

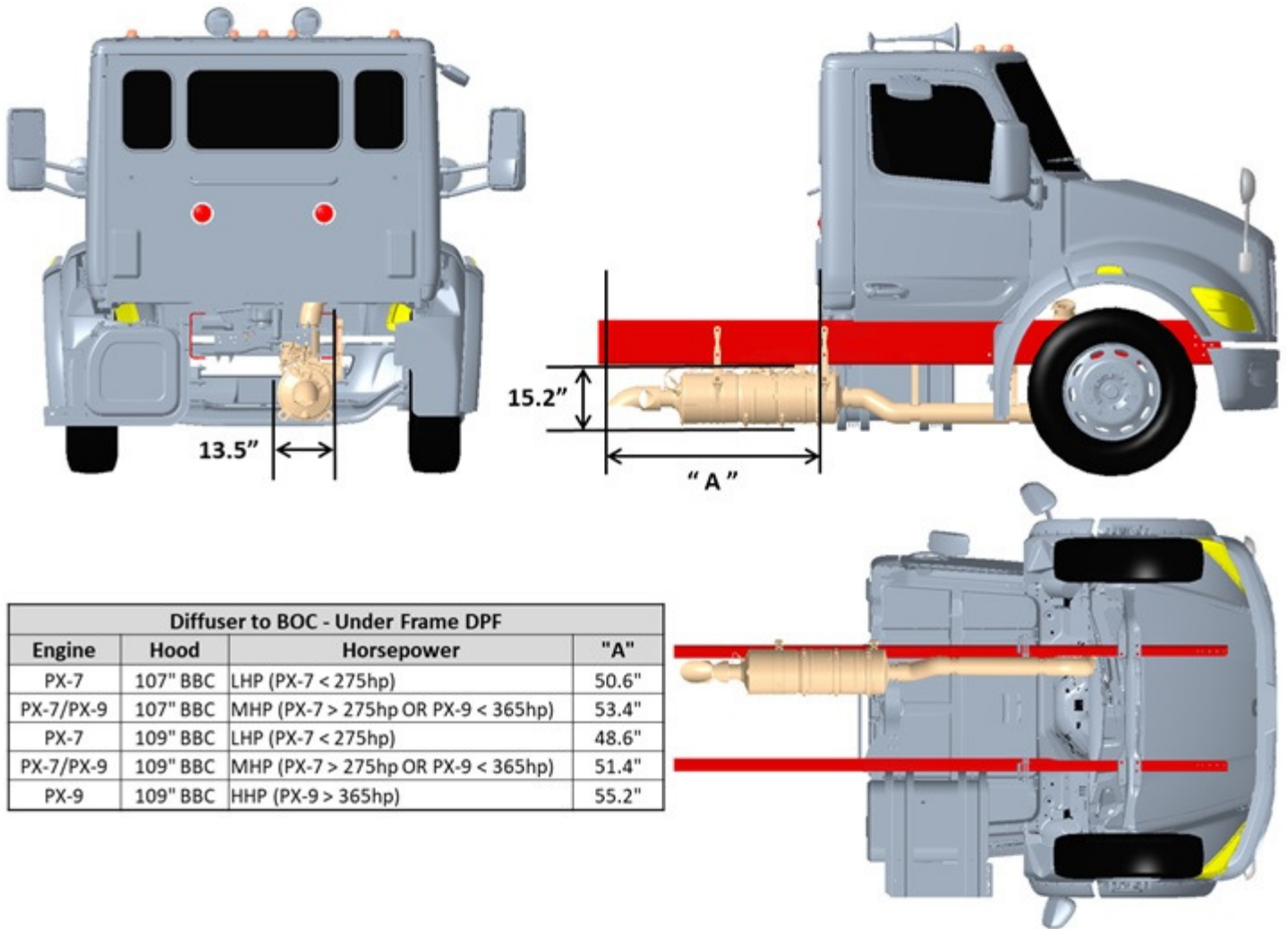
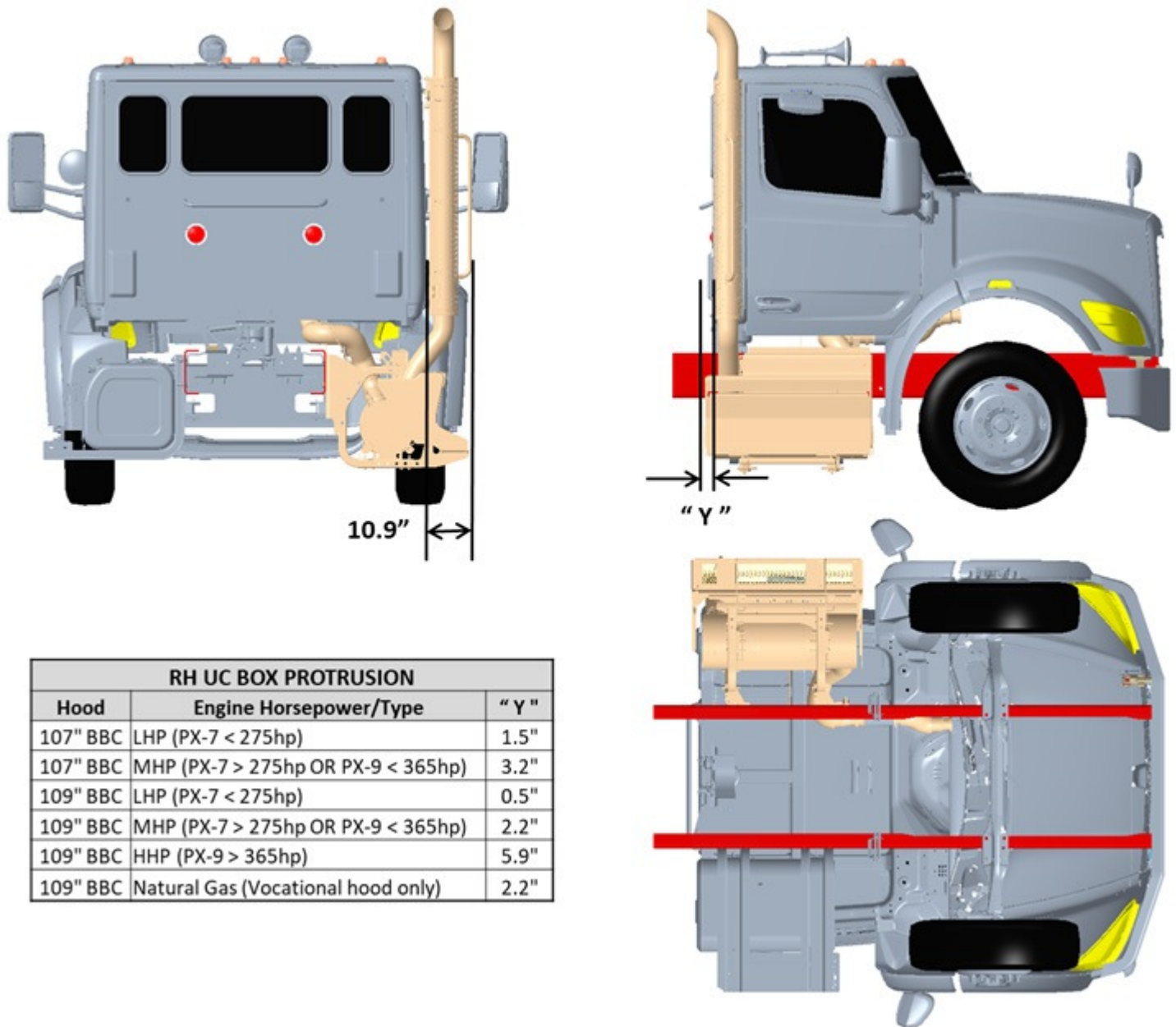

FIGURE 3-17. Exhaust RH Horizontal DPF/SCR RH under Frame

EXHAUST RH SOC - NATURAL GAS CATALYST RH UNDER CAB

(Reference option code 3365420)



RH UC BOX PROTRUSION		
Hood	Engine Horsepower/Type	"Y"
107" BBC	LHP (PX-7 < 275hp)	1.5"
107" BBC	MHP (PX-7 > 275hp OR PX-9 < 365hp)	3.2"
109" BBC	LHP (PX-7 < 275hp)	0.5"
109" BBC	MHP (PX-7 > 275hp OR PX-9 < 365hp)	2.2"
109" BBC	HHP (PX-9 > 365hp)	5.9"
109" BBC	Natural Gas (Vocational hood only)	2.2"

FIGURE 3-18. Exhaust Single RH Side of Cab DPF/SCR RH under Cab

EXHAUST RH BOC - NATURAL GAS CATALYST RH UNDER CAB

(Reference option code 3365440)

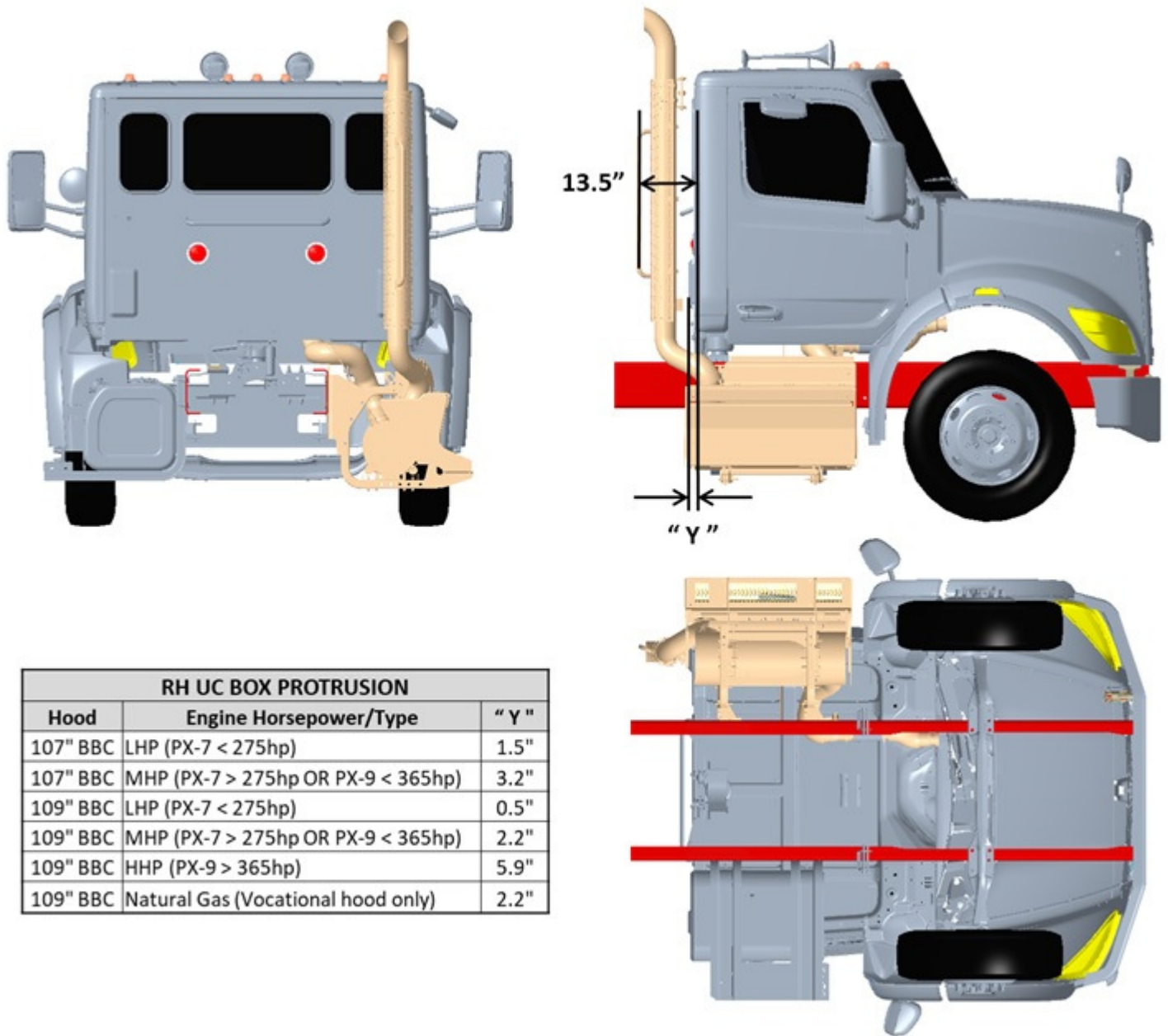

RH UC BOX PROTRUSION		
Hood	Engine Horsepower/Type	" Y "
107" BBC	LHP (PX-7 < 275hp)	1.5"
107" BBC	MHP (PX-7 > 275hp OR PX-9 < 365hp)	3.2"
109" BBC	LHP (PX-7 < 275hp)	0.5"
109" BBC	MHP (PX-7 > 275hp OR PX-9 < 365hp)	2.2"
109" BBC	HHP (PX-9 > 365hp)	5.9"
109" BBC	Natural Gas (Vocational hood only)	2.2"

FIGURE 3-19. Exhaust RH Back of Cab DPF/SCR RH under Cab

EXHAUST RH HORIZONTAL - NATURAL GAS CATALYST RH UNDER FRAME (L9N)
(Reference option code 3365460)

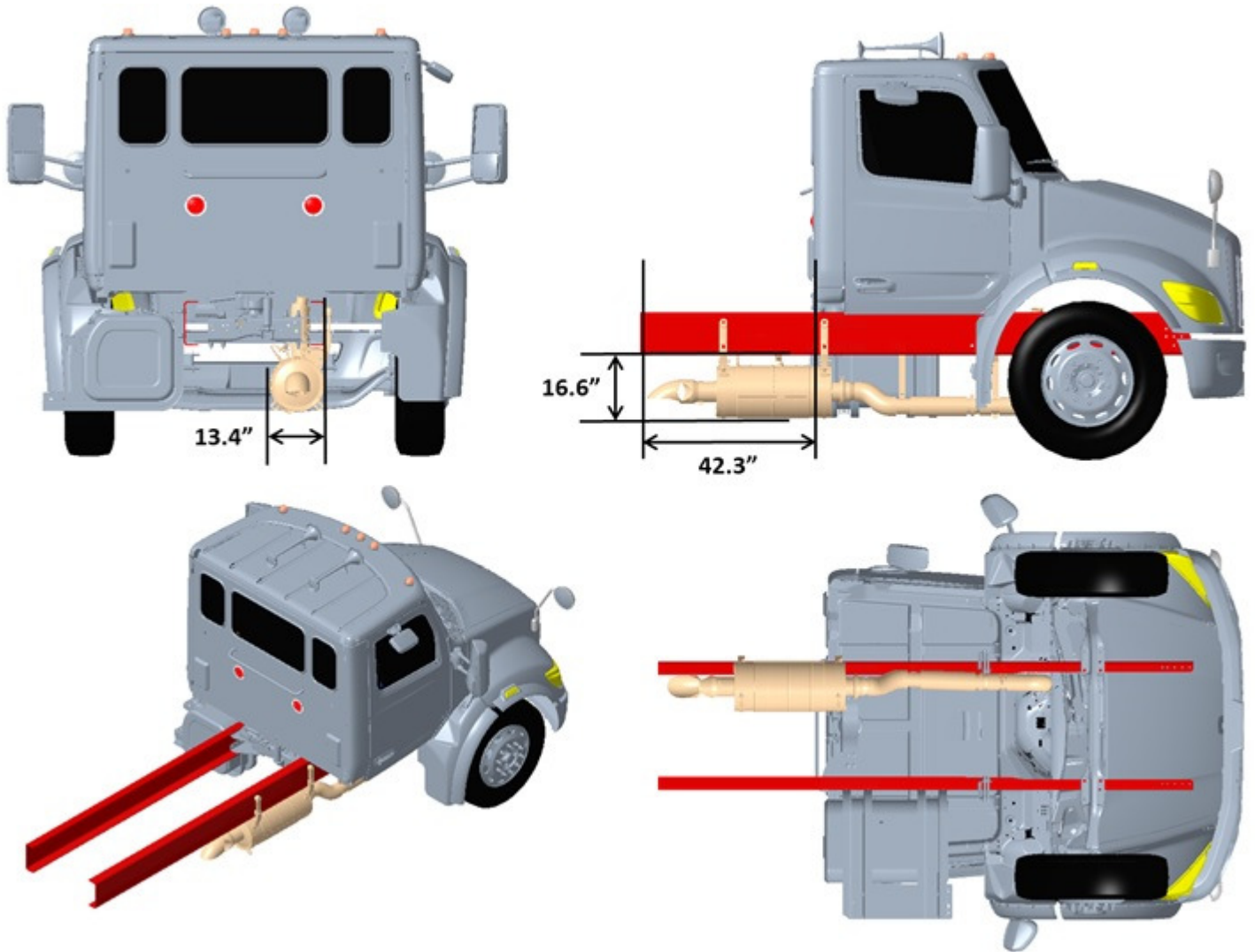

FIGURE 3-20. Exhaust RH Horizontal Natural Gas Catalyst RH under Frame (L9N)

EXHAUST RH HORIZONTAL - NATURAL GAS CATALYST RH UNDER FRAME (B6.7N)
(Reference option code 3365460)

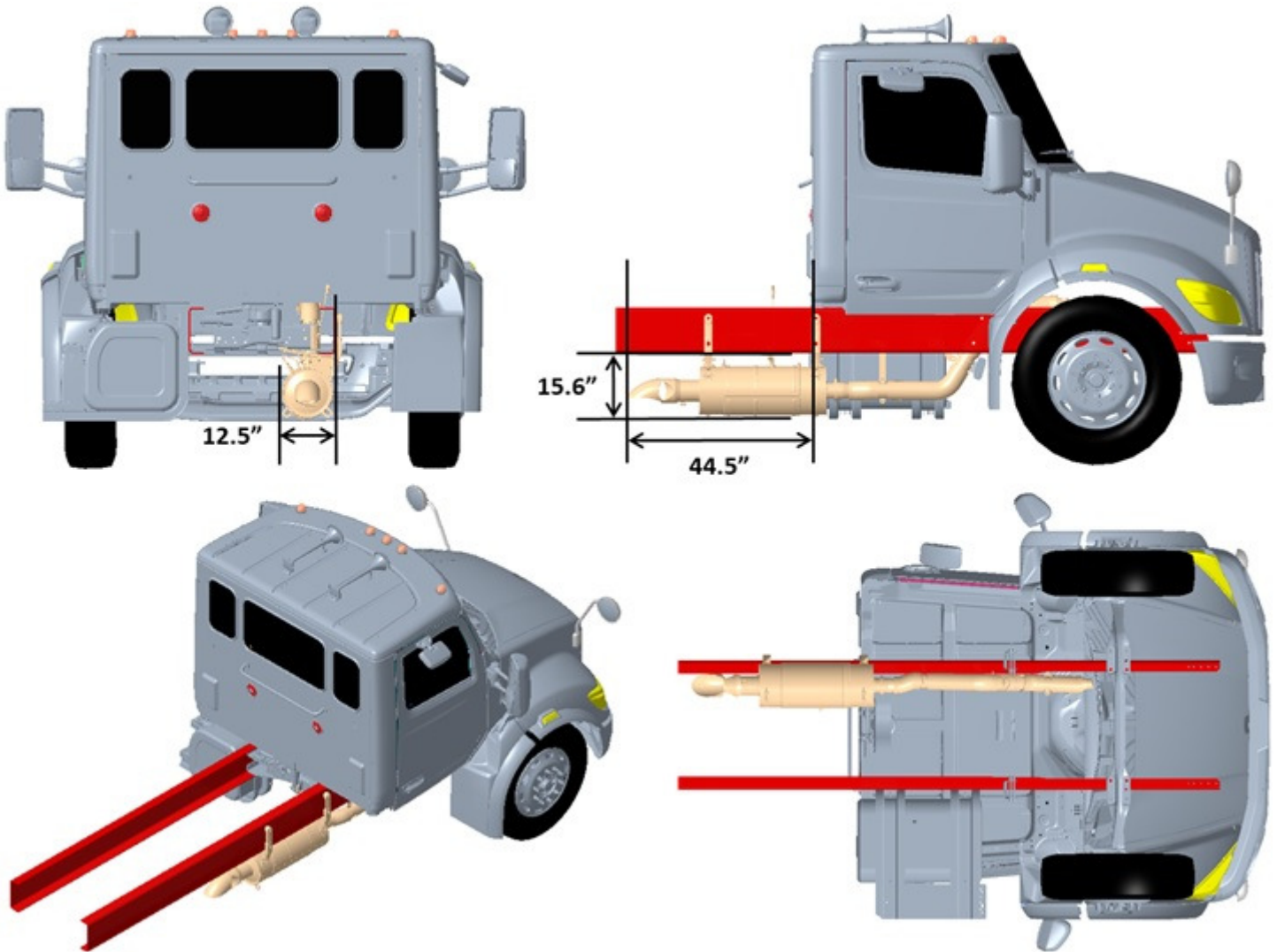

FIGURE 3-21. Exhaust RH Horizontal Natural Gas Catalyst RH under Frame (B6.7N)

TURN RADIUS ANALYSIS

Figure 3-22 is an example of turn radius estimates available through SmartSpec. Please contact your local Peterbilt dealer for chassis specific turn information.

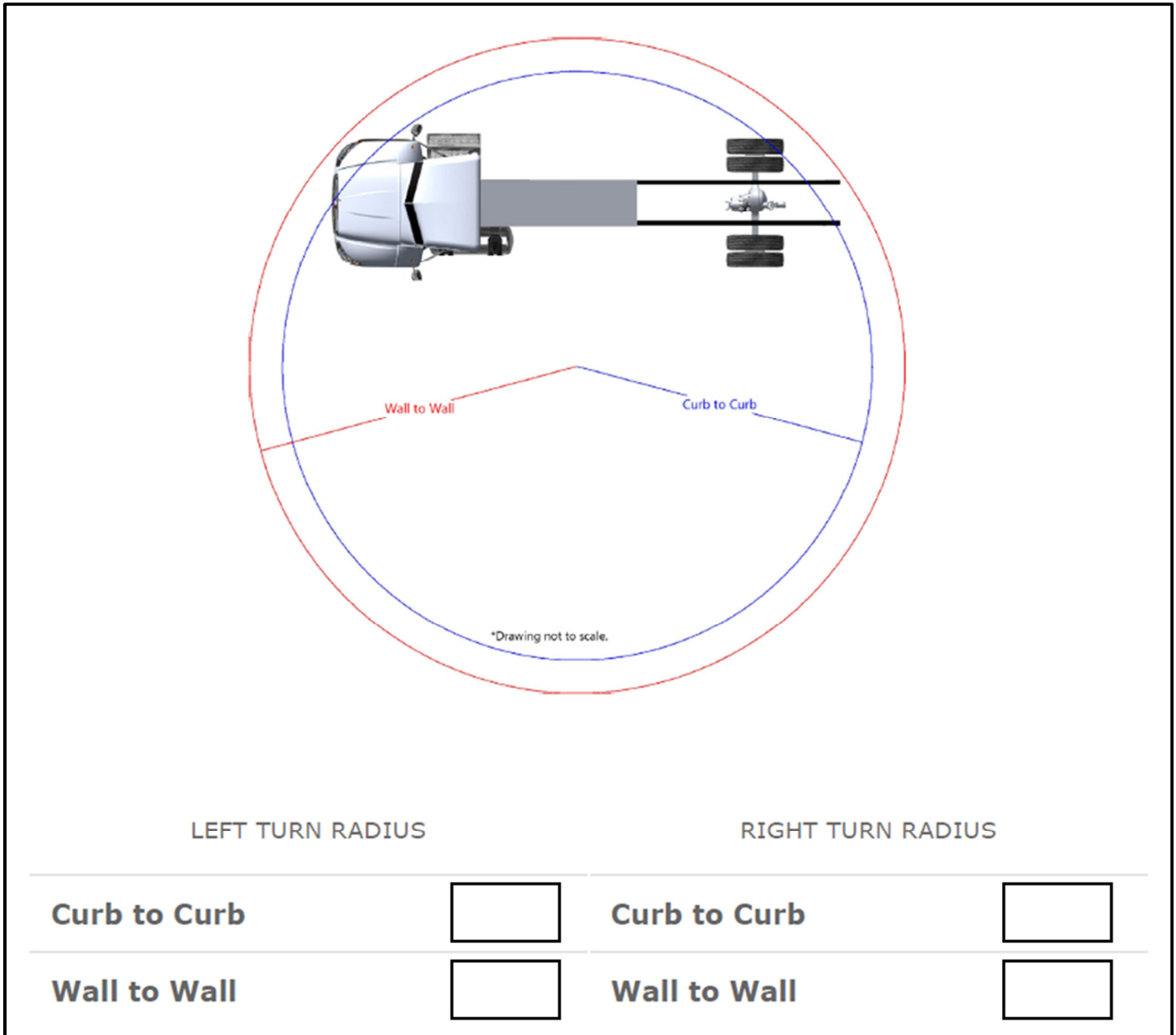

FIGURE 3-22. Turn Radius Estimate Available from Dealership

SECTION 4 BODY MOUNTING

INTRODUCTION

This section has been designed to provide guidelines to aid in body mounting. This is not intended as a complete guide, rather as general information. Body mounting strategies are unique to each body type, and body builders must determine the appropriate method. Please note, an alignment adjustment is required after body installation. Front alignment and rear alignment must be performed prior to putting the vehicle into service.

Please contact your local Peterbilt dealer if more information is desired.

FRAME RAILS

Frame rail information is provided per rail.

TABLE 4-1. Single Frame Rails

Rail Height (in.)	Flange Width (in.)	Web Thickness (in)	Section Modulus (cu. In.)	RBM (per rail) (in.-lbs)	Weight (per rail) (lbs/in.)
9 7/8	3.50	0.250	10.5	1,250,000	1.06
10 5/8	3.45	0.313	14.8	1,776,000	1.44
10 11/16	3.5	0.5	22.35	2,683,000	2.35
10 3/4	3.50	0.375	17.8	2,136,000	1.74
11 5/8	3.874	0.375	21.4	2,568,000	1.91

TABLE 4-2. Built-up Frame Rails

Main Rail Height (in.)	Insert	Outsert	Section Modulus (cu. In.)	RBM (per rail) (in.-lbs)	Weight (per rail) (lbs/in.)
10 5/8	9.875 x 2.87 x .25	None	23.6	2,832,000	2.48
10 3/4	9.875 x 2.87 x .25	None	28.9	3,468,000	2.78
11 5/8	10.75 x 3.5 x 0.375	None	37.7	4,524,000	3.65

CRITICAL CLEARANCES

REAR TIRES AND CAB



CAUTION: *Insufficient clearance between rear tires and body structure could cause damage to the body during suspension movement.*

Normal suspension movement could cause contact between the tires and the body. To prevent this, mount the body so that the minimum clearance between the top of the tire and the bottom of the body is 8 inches (203 mm). This should be measured with the body empty. See **FIGURE 4-1**.

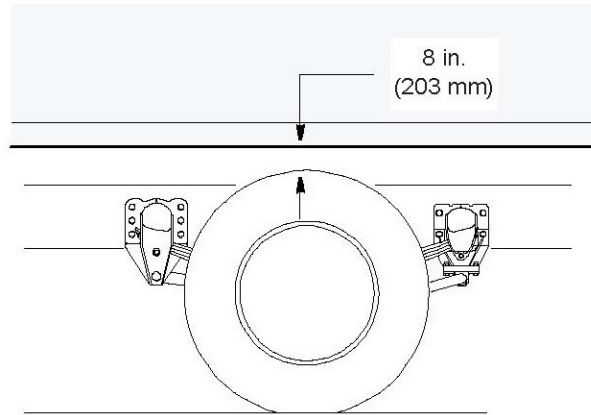

FIGURE 4-1. Minimum Clearance between Top of Rear Tires and Body Structure Overhang



CAUTION: *Maintain adequate clearance between back of cab and the front (leading edge) of mounted body. It is recommended the body leading edge be mounted 4 in. behind the cab. See **FIGURE 4-2**.*



NOTE: *Be sure to provide maintenance access to the battery box and fuel tank fill neck.*

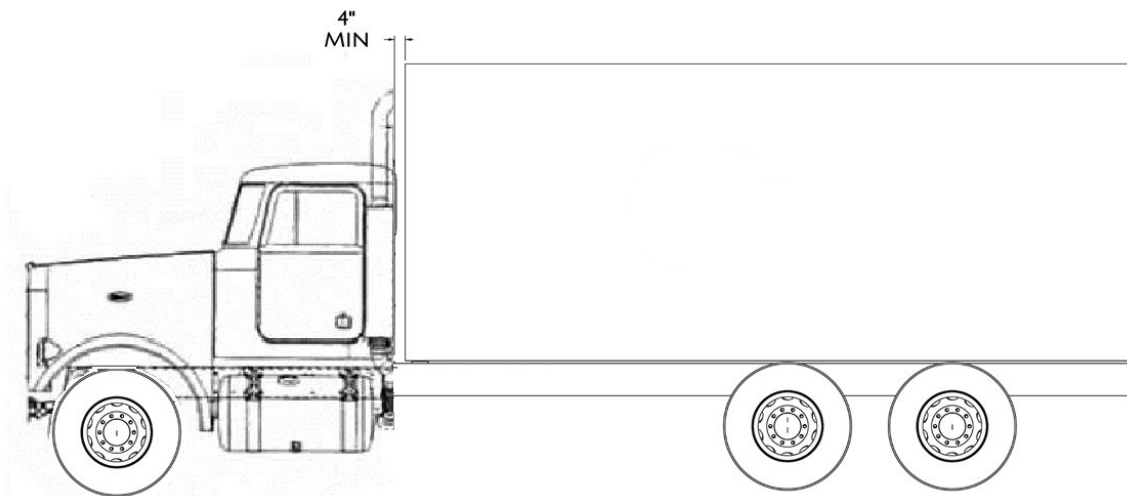

FIGURE 4-2. Minimum Back of Cab Clearance

BODY MOUNTING USING BRACKETS



CAUTION: Always install a spacer between the body subframe and the top flange of the frame rail. Installation of a spacer between the body subframe and the top flange of the frame rail will help prevent premature wear of the components due to chafing or corrosion.



WARNING! When mounting a body to the chassis, DO NOT drill holes in the upper or lower flange of the frame rail. If the frame rail flanges are modified or damaged, the rail could fail prematurely and cause an accident. Mount the body using body mounting brackets or U-bolts.

FRAME SILL

If the body is mounted to the frame with brackets, we recommend a frame sill spacer made from a strip of rubber or plastic (delrin or nylon). These materials will not undergo large dimensional changes during periods of high or low humidity. The strip will be less likely to fall out during extreme relative motion between body and chassis. See **FIGURE 4-3**.

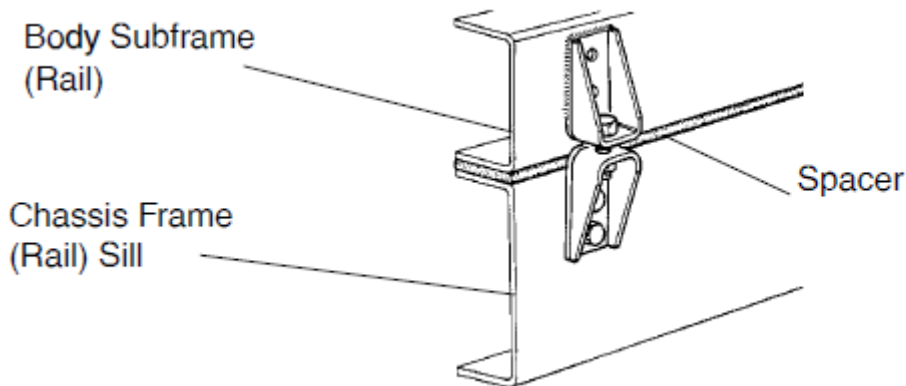
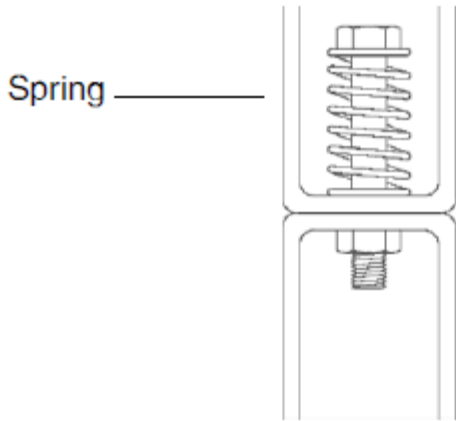
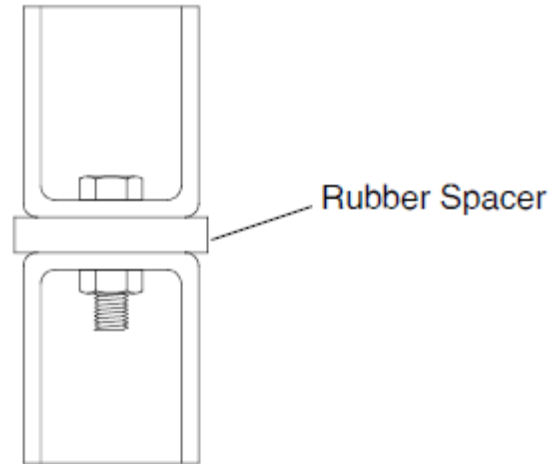

FIGURE 4-3. Spacer between Frame Sill and Body Rail – Rubber or Plastic

BRACKETS

When mounting a body to the chassis with brackets, we recommend designs that offer limited relative movement, bolted securely but not too rigid. Brackets should allow for slight movement between the body and the chassis. For instance, **FIGURE 4-4** shows a high compression spring between the bolt and the bracket, and **FIGURE 4-5** shows a rubber spacer between the brackets. These designs will allow relative movement between the body and the chassis during extreme frame racking situations. Mountings that are too rigid could cause damage to the body. This is particularly true with tanker installations.

**FIGURE 4-4.** Mounting Brackets**FIGURE 4-5.** Mounting Brackets

MOUNTING HOLES

When installing brackets on the frame rails, the mounting holes in the chassis frame bracket and frame rail must comply with the general spacing and location guidelines illustrated in **FIGURE 4-6**.

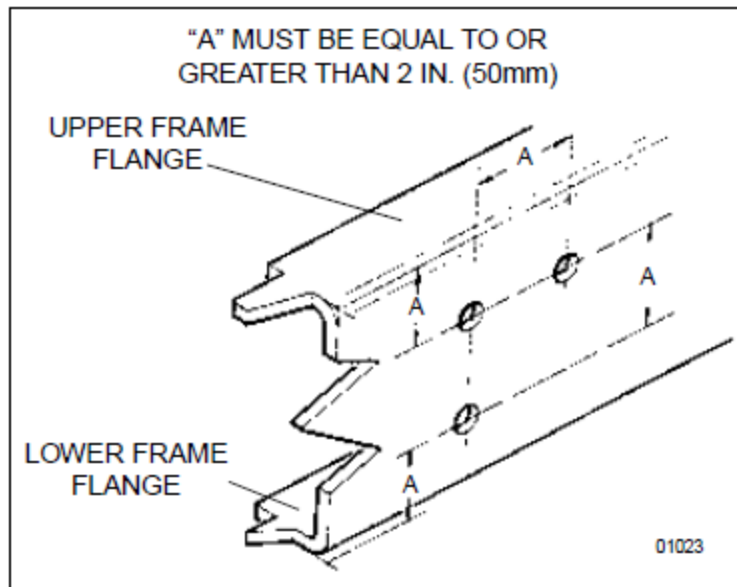

FIGURE 4-6. Frame Hole Location Guidelines for Frame Rail and Bracket

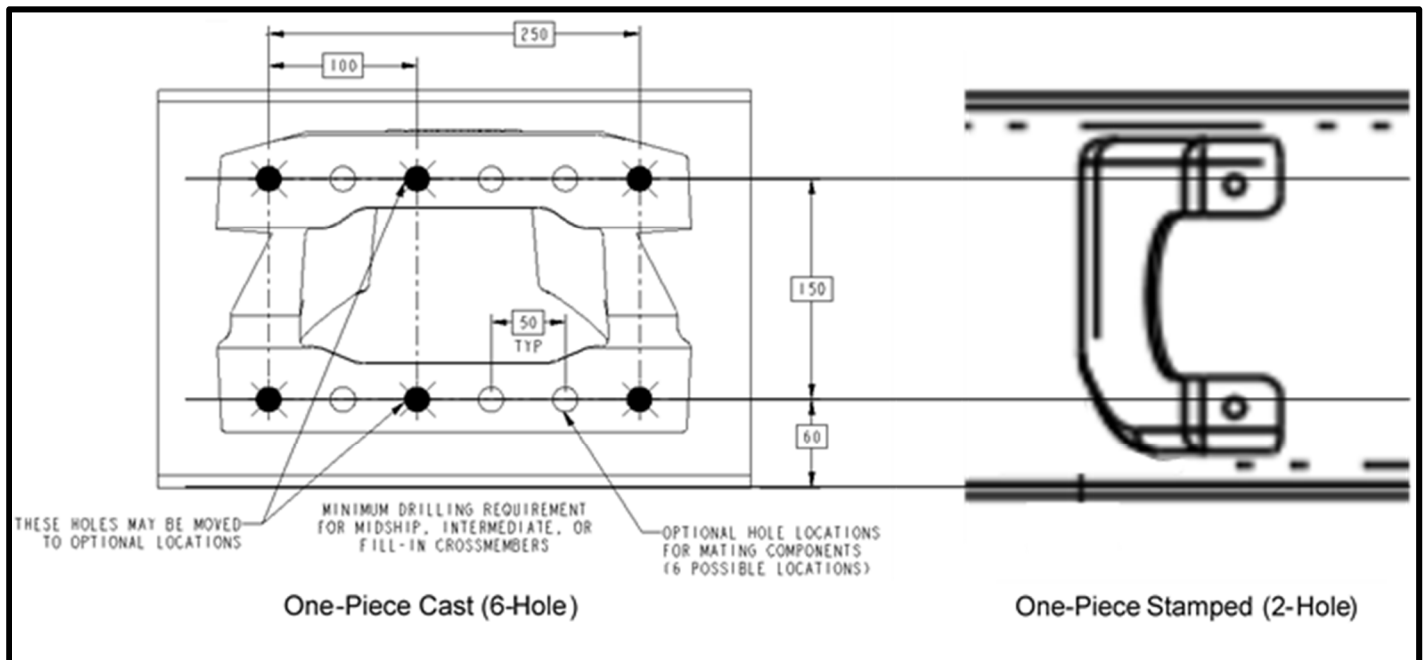

FIGURE 4-7. Fill-In Crossmember Gusset Hole Patterns (Additional Holes Available in 50 mm Horizontal Increments)

FRAME DRILLING

WARNING! When mounting a body to the chassis, **DO NOT** drill holes in the upper or lower flange of the frame rail. If the frame rail flanges are modified or damaged, the rail could fail prematurely and cause an accident. Mount the body using body mounting brackets or U-bolts.

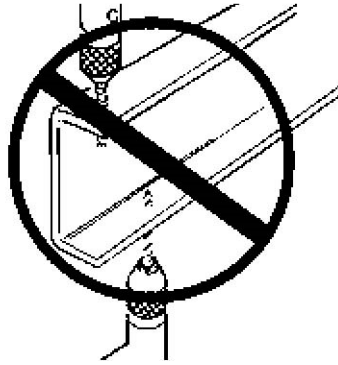

FIGURE 4-8. Frame Rail Flange Drilling Prohibited



WARNING! **DO NOT** drill closely spaced holes in the frame rail. Frame hole centers of two adjacent holes should be spaced no less than twice the diameter of the largest hole. Closer spacing could induce a failure between the two holes.



CAUTION: An appropriately sized bolt and nut must be installed and torqued properly in all unused frame holes. Failure to do so could result in a frame crack initiation around the hole.



CAUTION: Use care when drilling the frame web so the wires and air lines routed inside the rail are not damaged. Failure to do so could cause an inoperable electrical or air system circuit.



CAUTION: Never use a torch to make holes in the rail. Use the appropriate diameter drill bit. Heat from a torch will affect the material properties of the frame rail and could result in frame rail cracks.



CAUTION: The frame hole diameter should not exceed the bolt diameter by more than .060 inches (1.5mm).

BODY MOUNTING USING U-BOLTS

If the body is mounted to the frame with U-bolts, use a hardwood sill (minimum 1/2 inch thick) between the frame rail and body frame to protect the top surface of the rail flange.



WARNING! Do not allow the frame rails or flanges to deform when tightening the U-bolts. It will weaken the frame and could cause an accident. Use suitable spacers made of steel or hardwood on the inside of the frame rail to prevent collapse of the frame flanges.

Use a hardwood spacer between the bottom flange and the U-bolt to prevent the U-bolt from notching the frame flange. See **FIGURE 4-9**.

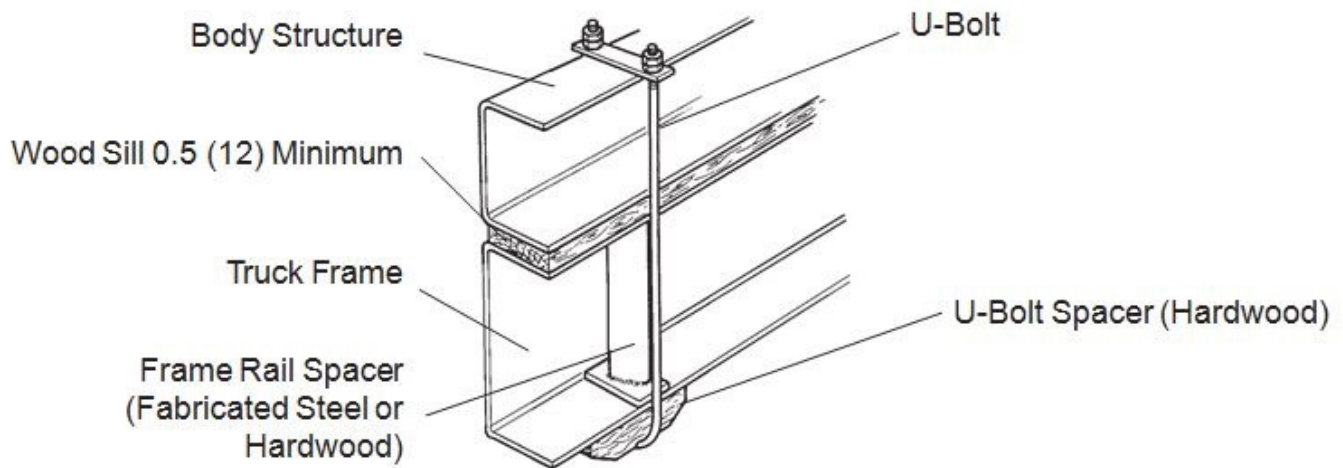

FIGURE 4-9. Acceptable U-Bolt Mounting with Wood and Fabricated Spacers



WARNING! Do not allow spacers and other body mounting parts to interfere with brake lines, fuel lines, or wiring harnesses routed inside the frame rail. Crimped or damaged brake lines, fuel lines, or wiring could result in loss of braking, fuel leaks, electrical overload or a fire. Carefully inspect the installation to ensure adequate clearances for air brake lines, fuel lines, and wiring. See **FIGURE 4-10**.

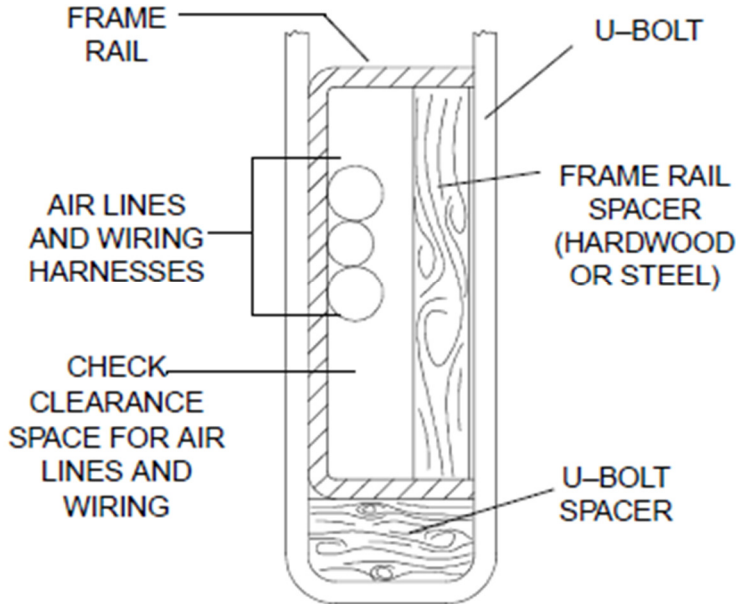
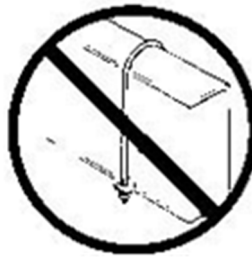

FIGURE 4-10. Clearance Space for Air Lines and Cables



WARNING! Do not notch frame rail flanges to force a U-bolt fit. Notched or damaged frame flanges could result in premature frame failure. Use a larger size U-bolt.



CAUTION: Mount U-bolts so they do not chafe on frame rail, air or electric lines.

REAR BODY MOUNT

When U-bolts are used to mount a body, we recommend that the last body attachment be made with a “fishplate” bracket. See **FIGURE 4-11**. This provides a firm attaching point and helps prevent any relative fore or aft movement between the body and frame. For frame hole location guidelines, see **FIGURE 4-6**.

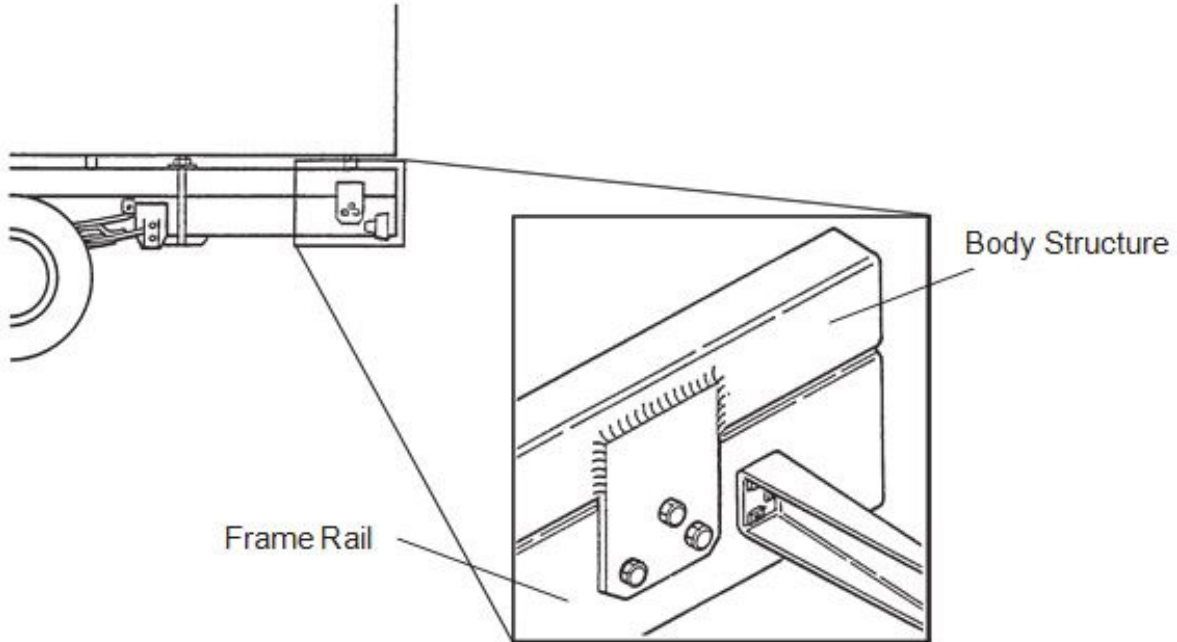

FIGURE 4-11. Fishplate Bracket at Rear End of Body

This page is intentionally left blank.

SECTION 5 FRAME MODIFICATIONS

INTRODUCTION

Peterbilt offers customer specified wheelbases and frame overhangs. So, in most cases, frame modifications should not be necessary.

However, some body installations may require slight modifications, while other installations will require extensive modifications. Sometimes an existing dealer stock chassis may need to have the wheelbase changed to better fit a customer's application. The modifications may be as simple as modifying the frame cutoff, or as complex as modifying the wheelbase.

DRILLING RAILS

If frame holes need to be drilled in the rail, see SECTION 4 BODY MOUNTING for more information.



WARNING! When mounting a body to the chassis, **DO NOT** drill holes in the upper or lower flange of the frame rail. If the frame rail flanges are modified or damaged, the rail could fail prematurely and cause an accident. Mount the body using body mounting brackets or U-bolts.



WARNING! Do not drill new holes any closer than 2 inches (50mm) to existing holes. Frame drilling affects the strength of the rails. If the holes are too close together, the rail could fail prematurely and cause an accident.



CAUTION: Use care when drilling the frame web so the wires and air lines routed inside the rail are not damaged.



WARNING! Never use a torch to make a hole in the rail. Use the appropriate diameter drill bit.

MODIFYING FRAME LENGTH

The frame overhang after the rear axle can be shortened to match a particular body length. Using a torch is acceptable; however, heat from a torch will affect the material characteristics of the frame rail. The affected material will normally be confined to within 1 to 2 inches (25 to 50mm) of the flame cut and may not adversely affect the strength of the chassis or body installation.

CHANGING WHEELBASE

Changing a chassis' wheelbase is not recommended. Occasionally, however, a chassis wheelbase will need to be shortened or lengthened. Before this is done, there are a few guidelines that should to be considered.



WARNING! *When changing the wheelbase, be sure to follow the driveline manufacturer's recommendations for driveline length or angle changes. Incorrectly modified drivelines can fail prematurely due to excessive vibration. This can cause an accident and severe personal injury.*



WARNING! *When changing the wheelbase, contact your local Peterbilt dealership for support. It is important to verify that these changes do not compromise vehicle frame strength.*

Before changing the wheelbase, the driveline angles of the proposed wheelbase need to be examined to ensure no harmful vibrations are created. Consult with the driveline manufacturer for appropriate recommendations.

Before the rear suspension is relocated, check the new location of the spring hanger brackets. The new holes for the spring hanger brackets must not overlap existing holes and should adhere to the guidelines in the "FRAME DRILLING" section of this manual.

When shortening the wheelbase, the suspension should be moved forward and relocated on the original rail. The rail behind the suspension can then be cut to achieve the desired frame overhang. See **FIGURE 5-1**.

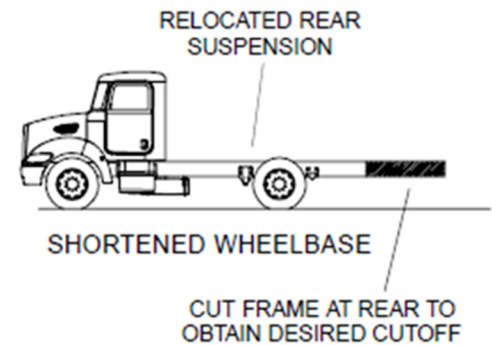
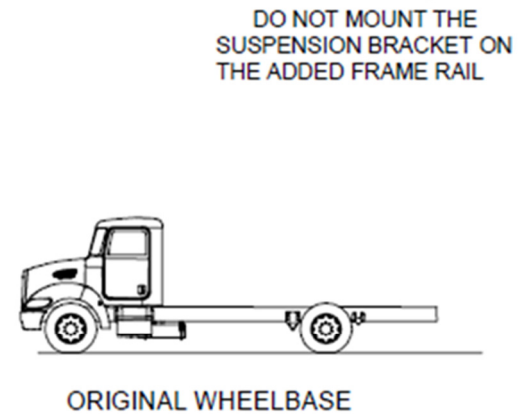
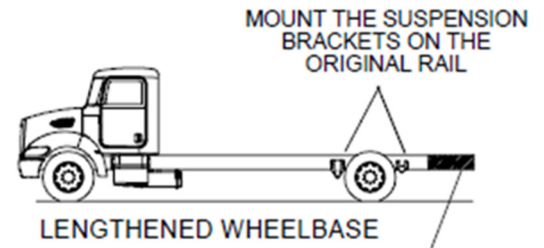

FIGURE 5-1. Wheelbase Customization

CROSSMEMBERS

After lengthening a wheelbase, an additional crossmember may be required to maintain the original frame strength. The maximum allowable distance between the forward suspension crossmember and the next crossmember forward is 47.2 inches (1200 mm). If the distance exceeds 47.2 inches (1200 mm) after the wheelbase is lengthened, add a crossmember between them.

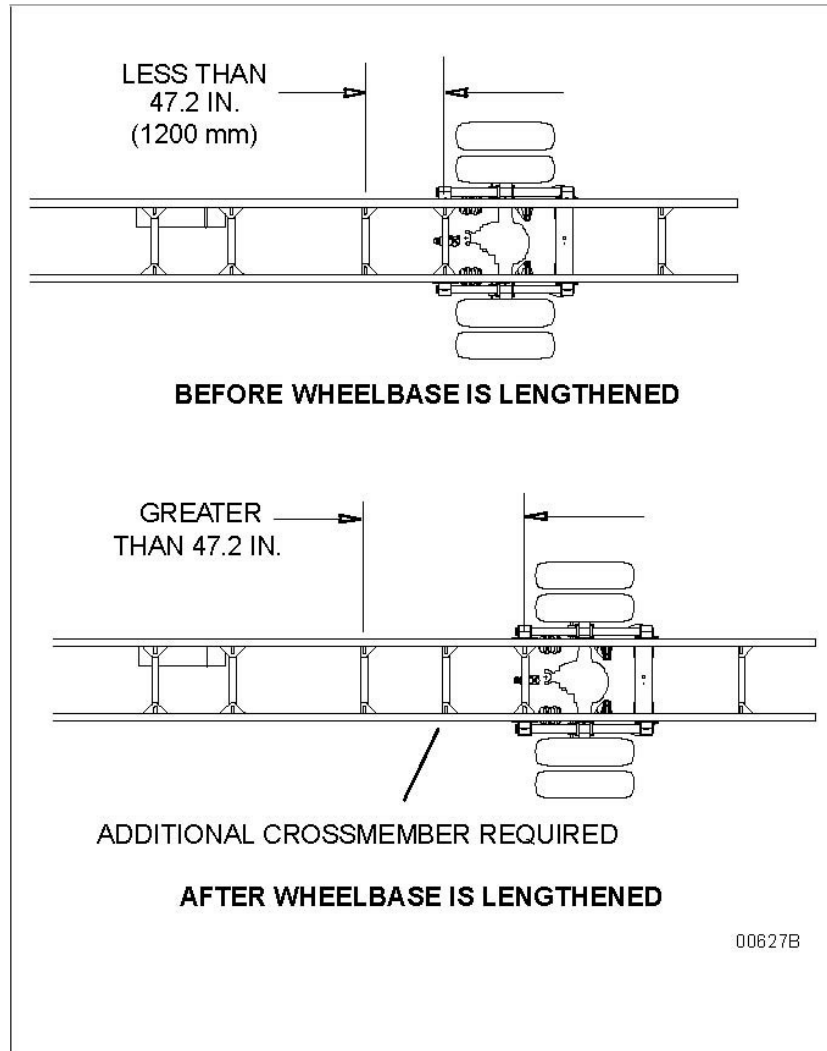

FIGURE 5-2. Crossmember Spacing Requirements

TORQUE REQUIREMENTS

Torque values apply to fasteners with clean threads, lightly lubricated, with hardened steel washers, and nylon-insert nuts.

TABLE 5-1. Customary Grade 8 UNF or UNC.

Fastener Size	Torque	
	Nm	lb-ft
5/16	27–34	20–25
3/8	47–60	35–44
7/16	76–96	56–71
1/2	117–148	86–109
9/16	167–214	123–158
5/8	235–296	173–218
3/4	411–523	303–386
7/8	654–846	482–624
1	973–1268	718–935

TABLE 5-2. U.S. Customary - Grade 8 Metric Class 10.9

Fastener Size	Torque	
	Nm	lb-ft
M6	9–11	7–8
M8	24–27	18–20
M10	47–54	35–40
M12	83–95	61–70
M14	132–150	97–111
M16	206–235	152–173
M20	403–458	297–338

WELDING

The frame rails are heat treated and should not be welded. The high heat of welding nullifies the special heat treatment of the rails, greatly reducing the tensile strength of the frame rail. If a frame member becomes cracked from overloading, fatigue, surface damage, or a collision, the only permanent repair is to replace the damaged frame member with a new part.

The following information is provided for temporary emergency repair. Prior to welding a cracked frame rail, the area should be beveled (V'd out) to allow for a better weld. To prevent spreading of the crack, a 7 to 9 mm (1/4 in. to 3/8 in.) diameter hole should be drilled at the end of the crack. Widen the crack along its full length by using two hack saw blades together. When welding steel frames use the shielded arc method. Be sure to obtain full weld penetration along the entire length of the crack.

PRECAUTIONS

CAUTION



Before welding, disconnect the alternator terminals. Failure to do so could result in damage to the voltage regulator and/or alternator.

CAUTION



To prevent damage to electrical equipment, disconnect battery cables before arc-welding on a truck, and be sure that the welding ground lead is connected to the frame. Bearings and other parts will be damaged if current must pass through them in order to complete the circuit.

WELDING PRECAUTIONS: ALL ELECTRONIC ENGINES

Before welding on vehicles with electronic engines, the following precautions should be observed.

CAUTION



1. Disconnect all electrical connections to the vehicle batteries.
2. Disconnect all ECM, TCM, and VECU connectors.
3. Do not use the ECM, TCM, VECU, or engine ground stud for the ground of the welding probe.
4. Ensure that the ground connection for the welder is as close to the weld point as possible. This ensures maximum weld current and minimum risk to damage electrical components on the vehicle.
5. Turn off key.

NOTE:



Bendix ABS and Wabco ABS: Disconnect ECU, TCM, & VECU.

This page is intentionally left blank.

SECTION 6 CAN COMMUNICATIONS

INTRODUCTION

Controller Area Network (CAN) is a serial network technology that was originally designed for the automotive industry but has also become popular in the commercial trucking industry. The CAN bus is primarily used in the embedded systems and network technology that provides fast communication among controllers up to real-time requirements, eliminating the need for the much more expensive and complex technology.

CAN is a two-wire high-speed network system, that is far superior to conventional hardwired technologies functionality and reliability. CAN implementations are more cost effective. CAN is designed for real-time requirements which can easily beat hardwire connections when it comes to short reaction times, timely error detection, quick error recovery, and error repair.

Characteristics of the Controller Area Network

- A serial networking technology for embedded solutions
- Needs only two wires to communicate messages
- Operates at data rates of 250K and 500K
- Supports a maximum of 8 bytes per message frame
- One application can support multiple message IDs
- Supports message priority, i.e. the lower the message ID the higher its priority

CAN COMMUNICATIONS ACRONYM LIBRARY

Acronym	Definition
CAN	Controller Area Network
J-1939	SAE CAN Communication Standard
PGN	Parameter Group Number
PTO	Power Take Off
SPN	Suspect Parameter Number
SCR	Selective Catalytic Reduction
DPF	Diesel Particulate Filter
Regen	Aftertreatment Regeneration
TSC1	Torque Speed Commands

SAE J1939

The Society of Automotive Engineers (SAE) Communications Subcommittee for Truck and Bus Controls has developed a family of standards concerning the design and use of devices that transmit electronic signals and control information among vehicle components. SAE J1939 and its companion documents are the accepted industry standard for the vehicle network of choice for commercial truck applications. SAE J1939 is used in the commercial vehicle area for communication in the embedded systems of the commercial vehicle.

SAE J1939 uses CAN as physical layer. It is a recommended practice that defines which and how the data is communicated between the Electronic Control Units within a vehicle network. Typical controllers are the Engine, Brake, Transmission, etc. The messages exchanged between these units can be data such as vehicle road speed, torque control message from the transmission to the engine, oil temperature, and many more.

Characteristics of J1939

- Extended CAN identifier (29 bit)
- Peer-to-peer and broadcast communication
- Network management
- Definition of parameter groups for commercial vehicles and others
- Manufacturer specific parameter groups are supported
- Diagnostics features
- A standard developed by the Society of Automotive Engineers
- Defines communication for vehicle networks
- A Higher-Layer Protocol using CAN as the physical layer
- Uses unshielded twisted pair wire
- Applies a maximum network length of 120 ft.
- Applies a standard baud rate of 500 Kbit/sec
- Supports peer-to-peer and broadcast communication
- Supports message lengths up to 1785 bytes
- Defines a set of Parameter Group Numbers
- Supports network management

PARAMETER GROUP NUMBER

Parameter Groups contain information on parameter assignments within the 8-byte CAN data field of each message as well as repetition rate and priority. Parameters groups are, for instance, engine temperature, which includes coolant temperature, fuel temperature, oil temperature, etc. Parameter Groups and their numbers are listed in SAE J1939 and defined in SAE J1939/71, a document containing parameter group definitions plus suspect parameter numbers.

SUSPECT PARAMETER NUMBER

A Suspect Parameter Number is a number assigned by the SAE to a specific parameter within a parameter group. It describes the parameter in detail by providing the following information:

Data Length in bytes
Data Type
Resolution
Offset
Range
Reference Tag (Label)

SPNs that share common characteristics are grouped into Parameter Groups, and they will be transmitted throughout the network using the Parameter Group Number.

CAN MESSAGES AVAILABLE ON BODY CONNECTIONS

SPN	CAN Signal Name	PGN, Message	Tx SA	Rx SA	CAN Bus
38	Fuel Level 2	65276, DD1	39	Broadcast	KCAN, SCAN, BCAN
46	Pneumatic Supply Pressure	65198, AIR1	48	Broadcast	KCAN, SCAN, BCAN
51	Engine Throttle Valve 1 Position 1	65266, LFE1	00	Broadcast	KCAN, SCAN, BCAN
52	Engine Intercooler Temperature	65262, ET1	00	Broadcast	KCAN, SCAN, BCAN
69	Two Speed Axle Switch	65265, CCVS1	00	Broadcast	KCAN, SCAN, BCAN
70	Parking Brake Switch	65265, CCVS1	39	Broadcast	KCAN, SCAN, BCAN
74	Maximum Vehicle Speed Limit	65261, CCSS	39	Broadcast	KCAN, SCAN
81	Aftertreatment 1 Diesel Particulate Filter Intake Pressure	65270, IC1	00	Broadcast	KCAN, SCAN, BCAN
84	Wheel-Based Vehicle Speed	65265, CCVS1	00	Broadcast	KCAN, SCAN, BCAN
86	Cruise Control Set Speed	65265, CCVS1	00	Broadcast	KCAN, SCAN, BCAN
86	Cruise Control Set Speed	65265, CCVS1	39	Broadcast	KCAN, SCAN
90	Power Takeoff Oil Temperature	65264, PTO	7, 33	Broadcast	KCAN, SCAN, BCAN
91	Accelerator Pedal Position 1	61443, EEC2	00	Broadcast	KCAN, SCAN, BCAN
92	Engine Percent Load At Current Speed	61443, EEC2	00	Broadcast	KCAN, SCAN, BCAN
94	Engine Fuel Delivery Pressure	65263, EFL/P1	00	Broadcast	KCAN, SCAN, BCAN
96	Fuel Level 1	65276, DD1	39	Broadcast	KCAN, SCAN, BCAN
97	Water In Fuel Indicator 1	65279, OI	00	Broadcast	KCAN, SCAN, BCAN
98	Engine Oil Level	65263, EFL/P1	00	Broadcast	KCAN, SCAN, BCAN
100	Engine Oil Pressure 1	65263, EFL/P1	00	Broadcast	KCAN, SCAN, BCAN
101	Engine Crankcase Pressure 1	65263, EFL/P1	00	Broadcast	KCAN, SCAN, BCAN
102	Engine Intake Manifold #1 Pressure	65270, IC1	00	Broadcast	KCAN, SCAN, BCAN
105	Engine Intake Manifold 1 Temperature	65270, IC1	00	Broadcast	KCAN, SCAN, BCAN
106	Engine Intake Air Pressure	65270, IC1	00	Broadcast	KCAN, SCAN, BCAN
108	Barometric Pressure	65269, AMB	00	Broadcast	KCAN, SCAN, BCAN
110	Engine Coolant Temperature	65262, ET1	00	Broadcast	KCAN, SCAN, BCAN
111	Engine Coolant Level 1	65263, EFL/P1	00	Broadcast	KCAN, SCAN, BCAN
117	Brake Primary Pressure	65274, B1	39	Broadcast	KCAN, SCAN, BCAN
118	Brake Secondary Pressure	65274, B1	39	Broadcast	KCAN, SCAN, BCAN
158	Key Switch Battery Potential	65271, VEP1	39	Broadcast	KCAN, SCAN
161	Transmission 1 Input Shaft Speed	61442, ETC1	03	Broadcast	KCAN, SCAN, BCAN
162	Transmission Requested Range	61445, ETC2	03	Broadcast	KCAN, SCAN, BCAN
163	Transmission Current Range	61445, ETC2	03	Broadcast	KCAN, SCAN, BCAN
168	Battery Potential / Power Input 1	65271, VEP1	39	Broadcast	KCAN, SCAN, BCAN
168	Battery Potential / Power Input 1	65271, VEP1	00	Broadcast	KCAN, SCAN, BCAN
171	Ambient Air Temperature	65269, AMB	00	Broadcast	KCAN, SCAN, BCAN
173	Engine Exhaust Temperature	65270, IC1	00	Broadcast	KCAN, SCAN, BCAN
174	Engine Fuel Temperature 1	65262, ET1	00	Broadcast	KCAN, SCAN, BCAN
175	Engine Oil Temperature 1	65262, ET1	00	Broadcast	KCAN, SCAN, BCAN
177	Transmission Oil Temperature 1	65272, TRF1	03	Broadcast	KCAN, SCAN, BCAN

SPN	CAN Signal Name	PGN, Message	Tx SA	Rx SA	CAN Bus
182	Engine Trip Fuel	65257, LFC1	00	Broadcast	KCAN, SCAN, BCAN
183	Engine Fuel Rate	65266, LFE1	00	Broadcast	KCAN, SCAN, BCAN
184	Engine Instantaneous Fuel Economy	65266, LFE1	00	Broadcast	KCAN, SCAN, BCAN
185	Engine Average Fuel Economy	65266, LFE1	23	Broadcast	KCAN, SCAN, BCAN
187	Power Takeoff Set Speed	65264, PTO	39	Broadcast	KCAN, SCAN, BCAN
187	Power Take Off Set Speed	65264, PTO	00	Broadcast	KCAN, SCAN, BCAN
190	Engine Speed	61444, EEC1	00	Broadcast	KCAN, SCAN, BCAN
191	Transmission 1 Output Shaft Speed	61442, ETC1	03	Broadcast	KCAN, SCAN, BCAN
235	Engine Total Idle Hours	65244, IO	00	Broadcast	KCAN, SCAN, BCAN
236	Engine Total Idle Fuel Used	65244, IO	00	Broadcast	KCAN, SCAN, BCAN
237	Vehicle Identification Number	65260, VI	00	Broadcast	KCAN, SCAN, BCAN
244	Trip Distance	65248, VD	00	Broadcast	KCAN, SCAN, BCAN
245	Total Vehicle Distance	65248, VD	00	Broadcast	KCAN, SCAN, BCAN
247	Engine Total Hours of Operation	65253, HOURS	00	Broadcast	KCAN, SCAN, BCAN
248	Total Power Takeoff Hours	65255, VH	00	Broadcast	KCAN, SCAN, BCAN
249	Engine Total Revolutions	65253, HOURS	00	Broadcast	KCAN, SCAN, BCAN
250	Engine Total Fuel Used	65257, LFC1	00	Broadcast	KCAN, SCAN, BCAN
512	Driver's Demand Engine - Percent Torque	61444, EEC1	00	Broadcast	KCAN, SCAN, BCAN
513	Actual Engine - Percent Torque	61444, EEC1	00	Broadcast	KCAN, SCAN, BCAN
518	Engine Requested Torque/Torque Limit	0, TSC1	39	249 (DA specific)	KCAN, SCAN, BCAN
518	Engine Requested Torque/Torque Limit	0, TSC1	7, 33	00 (DA specific)	KCAN, SCAN, BCAN
523	Transmission Current Gear	61445, ETC2	03	Broadcast	KCAN, SCAN, BCAN
524	Transmission Selected Gear	61445, ETC2	03	Broadcast	KCAN, SCAN, BCAN
525	Transmission Requested Gear	256, TC1	03	255 (DA specific)	KCAN, SCAN, BCAN
525	Trans Requested Gear	256, TC1	7, 33	03 (DA specific)	KCAN, SCAN, BCAN
526	Transmission Actual Gear Ratio	61445, ETC2	03	Broadcast	KCAN, SCAN, BCAN
527	Cruise Control States	65265, CCVS1	39	Broadcast	KCAN, SCAN, BCAN
527	Cruise Control States	65265, CCVS1	00	Broadcast	KCAN, SCAN
558	Accelerator Pedal1 Low Idle Switch	EEC2, 61443	00	Broadcast	KCAN, SCAN, BCAN
559	Accelerator Pedal Kick down Switch	61443, EEC2	00	Broadcast	KCAN, SCAN, BCAN
560	Transmission Driveline Engaged	61442, ETC1	03	Broadcast	KCAN, SCAN, BCAN
561	ASR Engine Control Active	61441, EBC1	39	Broadcast	KCAN, SCAN, BCAN
562	ASR Brake Control Active	61441, EBC1	39	Broadcast	KCAN, SCAN, BCAN
563	Anti-Lock Braking (ABS) Active	61441, EBC1	39	Broadcast	KCAN, SCAN, BCAN
573	Transmission Torque Converter Lockup Engaged	61442, ETC1	03	Broadcast	KCAN, SCAN, BCAN
574	Transmission Shift In Process	61442, ETC1	03	Broadcast	KCAN, SCAN, BCAN
590	Engine Idle Shutdown Timer State	65252, SHUTDN	00	Broadcast	KCAN, SCAN, BCAN
590	Engine Idle Shutdown Timer State	65252, SHUTDN	39	Broadcast	KCAN, SCAN, BCAN

SPN	CAN Signal Name	PGN, Message	Tx SA	Rx SA	CAN Bus
591	Engine Idle Shutdown Timer Function	65252, SHUTDN	00	Broadcast	KCAN, SCAN, BCAN
591	Engine Idle Shutdown Timer Function	65252, SHUTDN	39	Broadcast	KCAN, SCAN, BCAN
592	Engine Idle Shutdown Timer Override	65252, SHUTDN	00	Broadcast	KCAN, SCAN, BCAN
593	Engine Idle Shutdown has Shutdown Engine	65252, SHUTDN	00	Broadcast	KCAN, SCAN, BCAN
594	Engine Idle Shutdown Driver Alert Mode	65252, SHUTDN	00	Broadcast	KCAN, SCAN, BCAN
595	Cruise Control Active	65265, CCVS1	39	Broadcast	KCAN, SCAN, BCAN
595	Cruise Control Active	65265, CCVS1	00	Broadcast	KCAN, SCAN, BCAN
596	Cruise Control Enable Switch	65265, CCVS1	39	Broadcast	KCAN, SCAN, BCAN
597	Brake Switch	65265, CCVS1	39	Broadcast	KCAN, SCAN, BCAN
598	Clutch Switch	65265, CCVS1	39	Broadcast	KCAN, SCAN, BCAN
599	Cruise Control Set Switch	65265, CCVS1	39	Broadcast	KCAN, SCAN, BCAN
600	Cruise Control Coast (Decelerate) Switch	65265, CCVS1	39	Broadcast	KCAN, SCAN, BCAN
601	Cruise Control Resume Switch	65265, CCVS1	39	Broadcast	KCAN, SCAN, BCAN
602	Cruise Control Accelerate Switch	65265, CCVS1	39	Broadcast	KCAN, SCAN, BCAN
606	Engine Momentary Overspeed Enable	61442, ETC1	03	Broadcast	KCAN, SCAN, BCAN
607	Progressive Shift Disable	61442, ETC1	03	Broadcast	KCAN, SCAN, BCAN
684	Requested % Clutch Slip	256, TC1	7, 33	03 (DA specific)	KCAN, SCAN, BCAN
695	Engine Override Control Mode	0, TSC1	7, 33	00 (DA specific)	KCAN, SCAN, BCAN
696	Engine Requested Speed Control Conditions	0, TSC1	7, 33	00 (DA specific)	KCAN, SCAN, BCAN
897	Override Control Mode Priority	0, TSC1	7, 33	00 (DA specific)	KCAN, SCAN, BCAN
898	Engine Requested Speed/Speed Limit	0, TSC1	7, 33	00 (DA specific)	KCAN, SCAN, BCAN
899	Engine Torque Mode	61444, EEC1	00	Broadcast	KCAN, SCAN, BCAN
917	Total Vehicle Distance (High Resolution)	65217, VDHR	39	Broadcast	KCAN, SCAN, BCAN
969	Remote Accelerator Enable Switch	61441, EBC1	00	Broadcast	KCAN, SCAN, BCAN
970	Engine Auxiliary Shutdown Switch	61441, EBC1	7, 33, 160	Broadcast	KCAN, SCAN, BCAN
974	Remote Accelerator Pedal Position	61443, EEC2	7, 33	Broadcast	KCAN, SCAN, BCAN
974	Remote Accelerator Pedal Position	61443, EEC2	00	Broadcast	KCAN, SCAN, BCAN
975	Engine Fan 1 Estimated Percent Speed	65213, FD1	00	Broadcast	KCAN, SCAN, BCAN
976	PTO Governor State	65265, CCVS1	39	Broadcast	KCAN, SCAN, BCAN
976	PTO Governor State	65265, CCVS1	00	Broadcast	KCAN, SCAN, BCAN
976	PTO Governor State	65265, CCVS1	7, 33	Broadcast	KCAN, SCAN, BCAN
977	Fan Drive State	65213, FD1	00	Broadcast	KCAN, SCAN, BCAN
979	Engine Remote PTO Governor Preprogrammed Speed Control Switch	65264, PTO	7, 33	Broadcast	KCAN, SCAN, BCAN
979	Engine Remote PTO Governor Preprogrammed Speed Control Switch	65264, PTO	00	Broadcast	KCAN, SCAN, BCAN
980	Engine PTO Governor Enable Switch	65264, PTO	7, 33	Broadcast	KCAN, SCAN, BCAN
980	Engine PTO Governor Enable Switch	65264, PTO	00	Broadcast	KCAN, SCAN, BCAN

SPN	CAN Signal Name	PGN, Message	Tx SA	Rx SA	CAN Bus
982	Engine PTO Governor Resume Switch	65264, PTO	7, 33	Broadcast	KCAN, SCAN, BCAN
984	Engine PTO Governor Set Switch	65264, PTO	7, 33	Broadcast	KCAN, SCAN, BCAN
985	A/C High Pressure Fan Switch	65252, SHUTDN	00	Broadcast	KCAN, SCAN, BCAN
1028	Total Engine PTO Governor Fuel Used	65203, LFI1	00	Broadcast	KCAN, SCAN, BCAN
1040	Total Fuel Used (Gaseous)	65199, GFC	00	Broadcast	KCAN, SCAN, BCAN
1081	Engine Wait to Start Lamp	65252, SHUTDN	00	Broadcast	KCAN, SCAN, BCAN
1087	Service Brake Circuit 1 Air Pressure	65198, AIR1	39	Broadcast	KCAN, SCAN, BCAN
1087	Service Brake Circuit1 Air Pressure	65198, AIR1	11	Broadcast	KCAN, SCAN, BCAN
1087	Service Brake Circuit1 Air Pressure	65198, AIR1	48	Broadcast	KCAN, SCAN, BCAN
1088	Service Brake Circuit 2 Air Pressure	65198, AIR1	39	Broadcast	KCAN, SCAN, BCAN
1090	Air Suspension Supply Pressure 1	65198, AIR1	23	Broadcast	KCAN, SCAN, BCAN
1107	Engine Protection System Timer State	65252, SHUTDN	00	Broadcast	KCAN, SCAN, BCAN
1108	Engine Protection System Timer Override	65252, SHUTDN	00	Broadcast	KCAN, SCAN, BCAN
1109	Engine Protection System Approaching Shutdown	65252, SHUTDN	00	Broadcast	KCAN, SCAN, BCAN
1110	Engine Protection System Approaching Shutdown	65252, SHUTDN	00	Broadcast	KCAN, SCAN, BCAN
1111	Engine Protection System Configuration	65252, SHUTDN	00	Broadcast	KCAN, SCAN, BCAN
1172	Engine Turbocharger1 Compressor Intake Temperature	65178, TC12	00	Broadcast	KCAN, SCAN, BCAN
1184	Engine Turbocharger1 Turbine Outlet Temperature	TC15, 65175	00	Broadcast	KCAN, SCAN, BCAN
1214	Suspect Parameter Number	65226, DM1	39	Broadcast	KCAN, SCAN
1215	Failure Mode Identifier	65226, DM1	39	Broadcast	KCAN, SCAN
1216	Occurrence Count	65226, DM1	39	Broadcast	KCAN, SCAN
1437	Road Speed Limit Status	61443, EEC2	00	Broadcast	KCAN, SCAN, BCAN
1482	Source Address of Controlling Device for Transmission Control	61442, ETC1	03	Broadcast	KCAN, SCAN, BCAN
1483	Source Address of Controlling Device for Engine Control	61444, EEC1	00	Broadcast	KCAN, SCAN, BCAN
1487	Illumination Brightness Percent	53248, CL	39	74 (DA specific)	KCAN, SCAN
1639	Fan Speed	65213, FD1	00	Broadcast	KCAN, SCAN, BCAN
1675	Engine Starter Mode	61444, EEC1	00	Broadcast	KCAN, SCAN, BCAN
1706	SPN Conversion Method	65226, DM1	39	Broadcast	KCAN, SCAN
1761	Aftertreatment 1 Diesel Exhaust Fluid Tank Volume	65110, AT1T1I1	00	Broadcast	KCAN, SCAN, BCAN
1807	Steering Wheel Angle	61449, VDC2	11, 62	Broadcast	KCAN, SCAN, BCAN
1854	TransMode3	256, TC1	7, 33	03 (DA specific)	KCAN, SCAN, BCAN
1856	Seat Belt Switch	57344, CM1	39	255 (DA specific)	KCAN, SCAN
2347	High Beam Head Light Command	65089, LCMD	39	Broadcast	KCAN, SCAN, BCAN
2347	High Beam Head Light Command	65089, LCMD	7, 33, 160	Broadcast	KCAN, SCAN, BCAN

SPN	CAN Signal Name	PGN, Message	Tx SA	Rx SA	CAN Bus
2349	Low Beam Head Light Command	65089, LCMD	39	Broadcast	KCAN, SCAN, BCAN
2349	Low Beam Head Light Command	65089, LCMD	7, 33, 160	Broadcast	KCAN, SCAN, BCAN
2367	Left Turn Signal Lights Command	65089, LCMD	39	Broadcast	KCAN, SCAN, BCAN
2367	Left Turn Signal Lights Command	65089, LCMD	7, 33, 160	Broadcast	KCAN, SCAN, BCAN
2369	Right Turn Signal Lights Command	65089, LCMD	39	Broadcast	KCAN, SCAN, BCAN
2369	Right Turn Signal Lights Command	65089, LCMD	7, 33, 160	Broadcast	KCAN, SCAN, BCAN
2371	Left Stop Light Command	65089, LCMD	39	Broadcast	KCAN, SCAN, BCAN
2371	Left Stop Light Command	65089, LCMD	7, 33, 160	Broadcast	KCAN, SCAN, BCAN
2373	Right Stop Light Command	65089, LCMD	39	Broadcast	KCAN, SCAN, BCAN
2373	Right Stop Light Command	65089, LCMD	7, 33, 160	Broadcast	KCAN, SCAN, BCAN
2385	Rotating Beacon Light Command	65089, LCMD	39	Broadcast	KCAN, SCAN, BCAN
2385	Rotating Beacon Light Command	65089, LCMD	7, 33, 160	Broadcast	KCAN, SCAN, BCAN
2387	Tractor Front Fog Lights Command	65089, LCMD	39	Broadcast	KCAN, SCAN, BCAN
2387	Tractor Front Fog Lights Command	65089, LCMD	7, 33, 160	Broadcast	KCAN, SCAN, BCAN
2391	Back Up Light and Alarm Horn Command	65089, LCMD	39	Broadcast	KCAN, SCAN, BCAN
2391	Back Up Light and Alarm Horn Command	65089, LCMD	7, 33, 160	Broadcast	KCAN, SCAN, BCAN
2403	Running Light Command	65089, LCMD	39	Broadcast	KCAN, SCAN, BCAN
2403	Running Light Command	65089, LCMD	7, 33, 160	Broadcast	KCAN, SCAN, BCAN
2432	Engine Demand – Percent Torque	61444, EEC1	00	Broadcast	KCAN, SCAN, BCAN
2538	TransMode3Indicator	65098, ETC7	03	Broadcast	KCAN, SCAN, BCAN
2540	Parameter Group Number (RQST)	59904, RQST	251	255 (DA specific)	KCAN, SCAN
2540	Parameter Group Number (RQST)	59904, RQST	7, 33, 160	00 (DA specific)	KCAN, SCAN, BCAN
2609	Cab A/C Refrigerant Compressor Outlet Pressure	64993, CACI	25	Broadcast	KCAN, SCAN, BCAN
2641	Horn Switch	64980, CM3	7, 33, 160	Broadcast	KCAN, SCAN, BCAN
2863	Front Operator Wiper Switch	64973, OWW	39	Broadcast	KCAN, SCAN, BCAN
2873	Work Light Switch	64972, OEL	39	Broadcast	KCAN, SCAN, BCAN
2873	Work Light Switch	64972, OEL	7, 33, 160	Broadcast	KCAN, SCAN, BCAN
2875	Hazard Light Switch	64972, OEL	7, 33, 160	Broadcast	KCAN, SCAN, BCAN
2876	Turn Signal Switch	64972, OEL	39	Broadcast	KCAN, SCAN
2979	Vehicle Acceleration Rate Limit Status	61443, EEC2	39	Broadcast	KCAN, SCAN, BCAN
2979	Vehicle Acceleration Rate Limit Status	61443, EEC2	00	Broadcast	KCAN, SCAN, BCAN

SPN	CAN Signal Name	PGN, Message	Tx SA	Rx SA	CAN Bus
3026	Transmission Oil Level 1 Measurement Status	65272, TRF1	03	Broadcast	KCAN, SCAN, BCAN
3027	Transmission Oil Level 1 High / Low	65272, TRF1	03	Broadcast	KCAN, SCAN, BCAN
3028	Transmission Oil Level 1 Countdown Timer	65272, TRF1	03	Broadcast	KCAN, SCAN, BCAN
3031	Aftertreatment 1 Diesel Exhaust Fluid Tank Temperature 1	65110, AT1T1I1	00	Broadcast	KCAN, SCAN, BCAN
3246	Aftertreatment 1 Diesel Particulate Filter Outlet Temperature	64947, AT1OG2	00	Broadcast	KCAN, SCAN, BCAN
3349	TSC1 Transmission Rate	0, TSC1	7, 33	00 (DA specific)	KCAN, SCAN, BCAN
3350	TSC1 Control Purpose	0, TSC1	7, 33	00 (DA specific)	KCAN, SCAN, BCAN
3357	Actual Maximum Available Engine - Percent Torque	61443, EEC2	00	Broadcast	KCAN, SCAN, BCAN
3363	Aftertreatment 1 Diesel Exhaust Fluid Tank Heater	65110, AT1T1I1	00	Broadcast	KCAN, SCAN, BCAN
3447	Remote PTO Governor Preprogrammed Speed Control Switch #2	65264, PTO	7, 33	Broadcast	KCAN, SCAN, BCAN
3462	Engagement Status	64932, PTO	7, 33	Broadcast	KCAN
3462	Engagement Status	64932, PTO	7, 33	03 (DA specific)	SCAN, BCAN
3543	Engine Operating State	64914, EOI	00	Broadcast	KCAN, SCAN, BCAN
3606	Engine Controlled Shutdown Request	64914, EOI	00	Broadcast	KCAN, SCAN, BCAN
3607	Engine Emergency (Immediate) Shutdown Indication	64914, EOI	00	Broadcast	KCAN, SCAN, BCAN
3609	Aftertreatment 1 Diesel Particulate Filter Intake Pressure	64908, AT1GP	00	Broadcast (255)	KCAN, SCAN, BCAN
3610	Aftertreatment 1 Diesel Particulate Filter Outlet Pressure	64908, AT1GP	00	Broadcast	KCAN, SCAN, BCAN
3673	Engine Throttle Valve2 Position	65266, LFE1	00	Broadcast	KCAN, SCAN, BCAN
3695	Aftertreatment Regeneration Inhibit Switch	57344, CM1	7, 33, 160	255 (DA specific)	KCAN, SCAN, BCAN
3695	Aftertreatment Regeneration Inhibit Switch	57344, CM1	39	255 (DA specific)	KCAN, SCAN, BCAN
3696	Aftertreatment Regeneration Force Switch	57344, CM1	7, 33, 160	255 (DA specific)	KCAN, SCAN, BCAN
3696	Aftertreatment Regeneration Force Switch	57344, CM1	00	255 (DA specific)	KCAN, SCAN, BCAN
3696	Force Regen	57344, CM1	39	255 (DA specific)	KCAN, SCAN, BCAN
3697	Diesel Particulate Filter Lamp Command	64892, DPFC1	00	Broadcast	KCAN, SCAN, BCAN
3698	Exhaust System High Temperature Lamp Command	64892, DPFC1	00	Broadcast	KCAN, SCAN, BCAN
3700	Aftertreatment Diesel Particulate Filter Active Regeneration Status	64892, DPFC1	00	Broadcast	KCAN, SCAN, BCAN
3701	Aftertreatment Diesel Particulate Filter Status	64892, DPFC1	00	Broadcast	KCAN, SCAN, BCAN

SPN	CAN Signal Name	PGN, Message	Tx SA	Rx SA	CAN Bus
3702	Diesel Particulate Filter Active Regeneration Inhibited Status	64892, DPFC1	00	Broadcast	KCAN, SCAN, BCAN
3703	Diesel Particulate Filter Active Regeneration Inhibited Due to Inhibit Switch	64892, DPFC1	00	Broadcast	KCAN, SCAN, BCAN
3704	Diesel Particulate Filter Active Regeneration Inhibited Due to Clutch Disengaged	64892, DPFC1	00	Broadcast	KCAN, SCAN, BCAN
3705	Diesel Particulate Filter Active Regeneration Inhibited Due to Service Brake Active	64892, DPFC1	00	Broadcast	KCAN, SCAN, BCAN
3706	Diesel Particulate Filter Active Regeneration Inhibited Due to PTO Active	64892, DPFC1	00	Broadcast	KCAN, SCAN, BCAN
3707	Diesel Particulate Filter Active Regeneration Inhibited Due to Accelerator Pedal Off Idle	64892, DPFC1	00	Broadcast	KCAN, SCAN, BCAN
3708	Diesel Particulate Filter Active Regeneration Inhibited Due to Out of Neutral	64892, DPFC1	00	Broadcast	KCAN, SCAN, BCAN
3709	Diesel Particulate Filter Active Regeneration Inhibited Due to Vehicle Speed Above Allowed Speed	64892, DPFC1	00	Broadcast	KCAN, SCAN, BCAN
3710	Diesel Particulate Filter Active Regeneration Inhibited Due to Parking Brake Not Set	64892, DPFC1	00	Broadcast	KCAN, SCAN, BCAN
3711	Diesel Particulate Filter Active Regeneration Inhibited Due to Low Exhaust Temperature	64892, DPFC1	00	Broadcast	KCAN, SCAN, BCAN
3712	Diesel Particulate Filter Active Regeneration Inhibited Due to System Fault Active	64892, DPFC1	00	Broadcast	KCAN, SCAN, BCAN
3713	Diesel Particulate Filter Active Regeneration Inhibited Due to System Timeout	64892, DPFC1	00	Broadcast	KCAN, SCAN, BCAN
3716	Diesel Particulate Filter Active Regeneration Inhibited Due to Engine Not Warmed Up	64892, DPFC1	00	Broadcast	KCAN, SCAN, BCAN
3717	Diesel Particulate Filter Active Regeneration Inhibited Due to Vehicle Speed Below Allowed Speed	64892, DPFC1	00	Broadcast	KCAN, SCAN, BCAN
3718	Diesel Particulate Filter Automatic Active Regeneration Initiation Configuration	64892, DPFC1	00	Broadcast	KCAN, SCAN, BCAN
3719	Aftertreatment 1 Diesel Particulate Filter Soot Load Percent	64891, AT1S1	00	Broadcast	KCAN, SCAN, BCAN
3721	Aftertreatment 1 Diesel Particulate Filter Time Since Last Active Regeneration	64891, AT1S1	00	Broadcast	KCAN, SCAN, BCAN
3948	At least one PTO engaged	64932, PTODE	39	Broadcast	KCAN, SCAN, BCAN
4154	Actual Engine - Percent Torque (Fractional)	61444, EEC1	00	Broadcast	KCAN, SCAN, BCAN
4175	Diesel Particulate Filter Active Regeneration Forced Status	64892, DPFC1	00	Broadcast	KCAN, SCAN, BCAN
4191	Engine Requested Torque (Fractional)	0, TSC1	7, 33	00 (DA specific)	KCAN, SCAN, BCAN
4206	Message Counter	0, TSC1	7, 33	00 (DA specific)	KCAN, SCAN, BCAN
4207	Message Checksum	0, TSC1	7, 33	00 (DA specific)	KCAN, SCAN, BCAN
4765	Aftertreatment 1 Diesel Oxidation Catalyst Intake Temperature	64800, A1DOC1	00	Broadcast	KCAN, SCAN, BCAN

SPN	CAN Signal Name	PGN, Message	Tx SA	Rx SA	CAN Bus
4816	Transmission Torque Converter Lockup Transition in Process	61442, ETC1	03	Broadcast	KCAN, SCAN, BCAN
5078	Engine Amber Warning Lamp Command	64775, DLCC1	00	Broadcast	KCAN, SCAN, BCAN
5079	Engine Red Stop Lamp Command	64775, DLCC1	00	Broadcast	KCAN, SCAN, BCAN
5082	Engine Oil Pressure Low Lamp Command	64775, DLCC1	00	Broadcast	KCAN, SCAN, BCAN
5083	Engine Coolant Temperature High Lamp Command	64775, DLCC1	00	Broadcast	KCAN, SCAN, BCAN
5084	Engine Coolant Level Low Lamp Command	64775, DLCC1	00	Broadcast	KCAN, SCAN, BCAN
5086	Engine Air Filter Restriction Lamp Command	64775, DLCC1	23	Broadcast	KCAN, SCAN, BCAN
5087	Vehicle Battery Voltage Low Lamp Command	64774, DLCC2	23	Broadcast	KCAN, SCAN, BCAN
5088	Vehicle Fuel Level Low Lamp Command	64774, DLCC2	23	Broadcast	KCAN, SCAN, BCAN
5245	Aftertreatment Diesel Exhaust Fluid Tank Low Level Indicator	65110, AT1T1I1	00	Broadcast	KCAN, SCAN, BCAN
5246	Aftertreatment SCR Operator Inducement Severity	65110, AT1T1I1	00	Broadcast	KCAN, SCAN, BCAN
5398	Estimated Pumping - Percent Torque	61443, EEC2	00	Broadcast	KCAN, SCAN, BCAN
5399	DPF Thermal Management Active	61443, EEC2	00	Broadcast	KCAN, SCAN, BCAN
5400	SCR Thermal Management Active	61443, EEC2	00	Broadcast	KCAN, SCAN, BCAN
5466	Aftertreatment 1 Diesel Particulate Filter Soot Load Regeneration Threshold	64891, AT1S1	00	Broadcast	KCAN, SCAN, BCAN
5676	Forward Collision Advanced Emergency Braking System State	61487, AEBS1	42	Broadcast	KCAN, SCAN
5825	Driver Warning System Indicator Status	65279, OI	00	Broadcast	KCAN, SCAN, BCAN
8484	Demanded Brake Application Pressure	61712, B2	39	Broadcast	KCAN, SCAN, BCAN
12308	Headlamp Emergency Flash Switch	64972, OEL	7, 33	Broadcast	SCAN
12308	Headlamp Emergency Flash Switch	64972, OEL	7, 33	Broadcast	KCAN
12308	Headlamp Emergency Flash Switch	64972, OEL	7, 33	Broadcast	BCAN
12964	Auxiliary Lamp Group Switch	64972, OEL	39	Broadcast	KCAN, SCAN, BCAN
12964	Auxiliary Lamp Group Switch	64872, OEL	7, 33, 160	Broadcast	KCAN, SCAN, BCAN
13105	Engine Oil Temperature High Lamp Command	64775, DLCC1	23	Broadcast	KCAN, SCAN, BCAN
13108	Primary Air Pressure Low Lamp Command	64774, DLCC2	23	Broadcast	KCAN, SCAN, BCAN
13109	Secondary Air Pressure Low Lamp Command	64774, DLCC2	23	Broadcast	KCAN, SCAN, BCAN
13116	Transmission Oil Temperature High Lamp Command	64775, DLCC1	23	Broadcast	KCAN, SCAN, BCAN
13132	Air Suspension Supply Pressure 2	64195, AIR3	23	Broadcast	KCAN, SCAN, BCAN

SECTION 7 ELECTRICAL

INTRODUCTION

This section is written to provide information to the body builder when installing equipment into vehicles built with multiplexed instrumentation. The technology presented by VECU level instrumentation integrates J-1939 CAN data communications between controllers and equipment on the vehicle. This section is intended to address how to work in aftermarket equipment while still maintaining full functionality of the OEM vehicle.

These topics apply to 2.1M medium duty chassis built with a Vehicle Electronic Control Unit (VECU). The electrical architecture for these trucks will be named VMUX, which replaces NAMUX3. This system integrates a parallel control unit to manage outbound messages via a faster baud rate 500kbps and FCAN signals for the chassis module(s). Since the F-CAN has moved to the VECU, the VCAN is divided into VCAN1 and VCAN2. The second CAN is dedicated to OBD communication.

The most important advancement of electrical instrumentation is the implementation of the VECU controller. While it is still possible to wire completely outside of the VECU system, utilizing the VECU functions will make a cleaner installation and will maintain OEM functionality. VECU expands controls to air operated devices by receiving input from dash switches, remote (aftermarket) switches, sensors mounted to the aftermarket equipment and other vehicle parameters (engine speed, transmission status etc.) With the proper programming, the VECU will then process the inputs and will create a J-1939 Data instruction, which is communicated to another controller outside the cab called the Chassis Module. This chassis module receives the instruction and communicates the information to the air solenoid bank. Then 12V power will open the solenoid and supply air pressure to the specified air circuit. The chassis module can also supply voltage to other systems on the chassis.

ELECTRICAL ACRONYM LIBRARY

Acronym	Definition
CAN	Controller Area Network
DTC	Diagnostics Trouble Code
ECM	Engine Control Module
ECU	Electrical Control Unit
EOA	Electric Over Air
EOH	Electric Over Hydraulic
J-1939	SAE CAN Communication Standard
LIN	Local Interconnect Network
MSB	Master Solenoid Bank
MSM	Master Switch Module
MUX	Multiplex Switch
OBD	On Board Diagnostics
OEM	Original Equipment Manufacturer
PCC	Predictive Cruise Control
PDC	Power Distribution Center
PGN	Parameter Group Number
PTO	Power Take Off
RP1226	TMS Messaging Standard
SPN	Suspect Parameter Number
TCM	Transmission Control Module
VECU	Vehicle Electronic Control Unit

ELECTRICAL WIRING CIRCUIT CODES

The wire system uses 10 different colors and only one striped wire color. Each wire has a minimum of seven characters, with the first three characters as the wire color. The remaining four characters are related to the wire services. The colors determine the circuits function as follows:

ELECTRICAL WIRE CIRCUIT CODE TABLES

PACCAR Electrical Circuit Code		
Insulation Color	Color Code	Electrical Function
Red w/ white stripe	R/WXXXX	Direct battery power
Red	REDXXXX	Protected battery power
Orange	ORNXXXX	Ignition, Accessory, Low Voltage Disconnect, StartPower
Yellow	YELXXXX	Activated Power
White	WHTXXXX	Ground
Black	BLKXXXX	Load Return
Gray	GRAXXXX	Control
Brown	BRNXXXX	Indicator Illumination Backlit Illumination
Violet	VIOXXXX	Reference Voltage or +5VDC or Sensor Power
Light Blue	BLUXXXX	Sensor Signal
Light Green	GRNXXXX	Sensor common or Sensor Ground

Number			Category
XXX0000	through	XXX0999	General
XXX1000	through	XXX1999	Power Supply
XXX2000	through	XXX2999	Lighting
XXX3000	through	XXX3999	Powertrain
XXX4000	through	XXX4999	Instrumentation
XXX5000	through	XXX5999	Safety systems
XXX6000	through	XXX6999	Convenience, Security
XXX7000	through	XXX7999	HVAC
XXX8000	through	XXX8999	Undefined
XXX9000	through	XXX9999	Trailer/Body Connections

MULTIPLEX SYSTEM

The VECU electrical architecture uses a multiplexing system. Multiplexing can be defined as the process of sending multiple digital signals on the same shared medium at the same time. These signals are introduced into the multiplexing system through data connection points, which are defined by J1939 backbone.

CAN BUS SYSTEM OVERVIEW

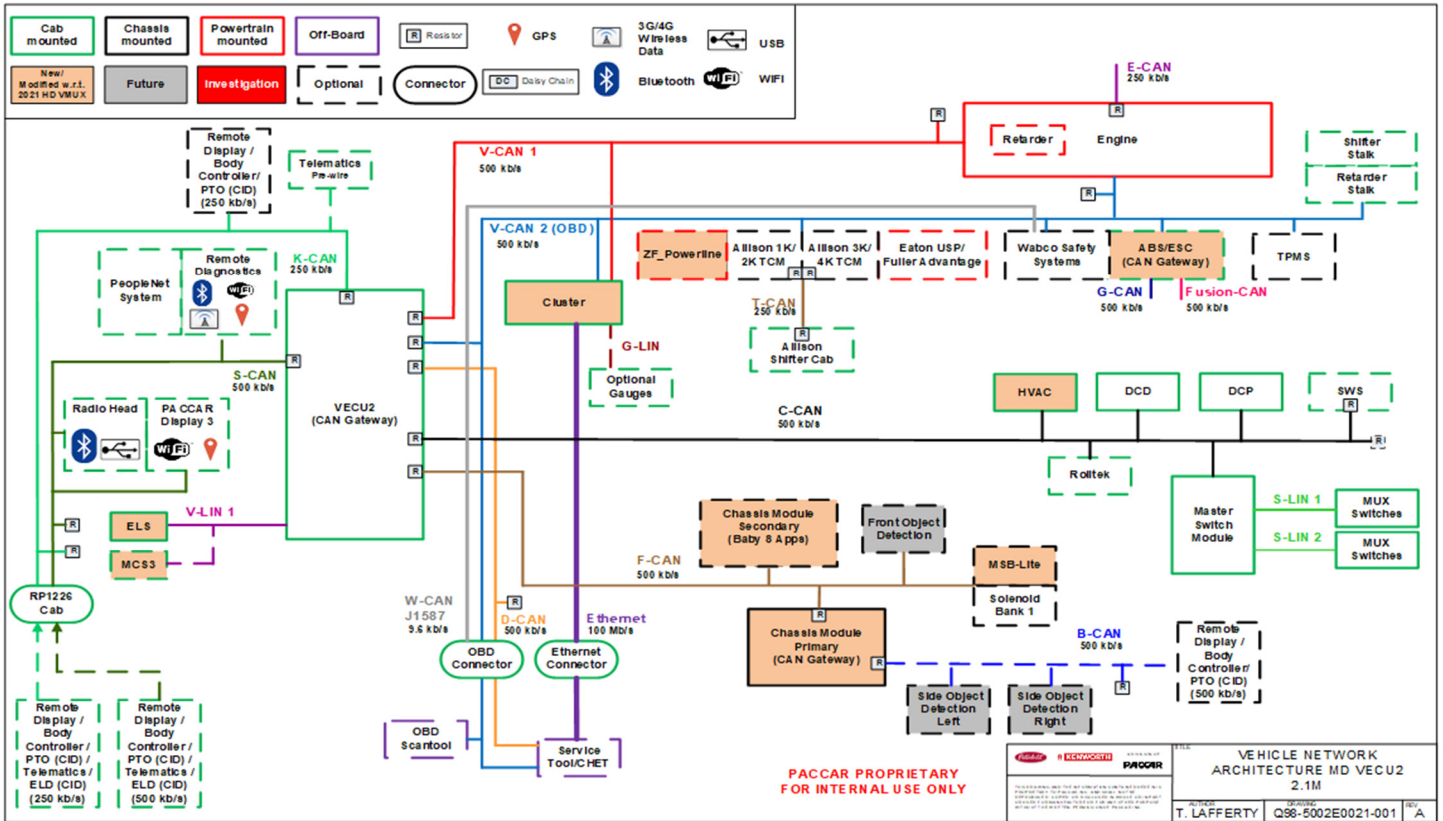

CAN BUS SPEEDS AND CIRCUIT DESIGNATION

J1939-14 (500KBPS):

- B-CAN – 0813 Body Builder
- C-CAN – 0821 Cab
- D-CAN – 0822 Diagnostics
- F-CAN – 0819 Frame
- G-CAN – 0825 Bendix ACB Antenna
- S-CAN – 0827 Radio and PACCAR Display
- V-CAN1 – 0812 Vehicle1
- V-CAN2 – 0823 Vehicle2

J1939-15 (250KBPS):

- T-CAN – 0828 Transmission
- K-CAN – 0829 Telematics and Remote PTO

ELECTRICAL COMPONENT OVERVIEW

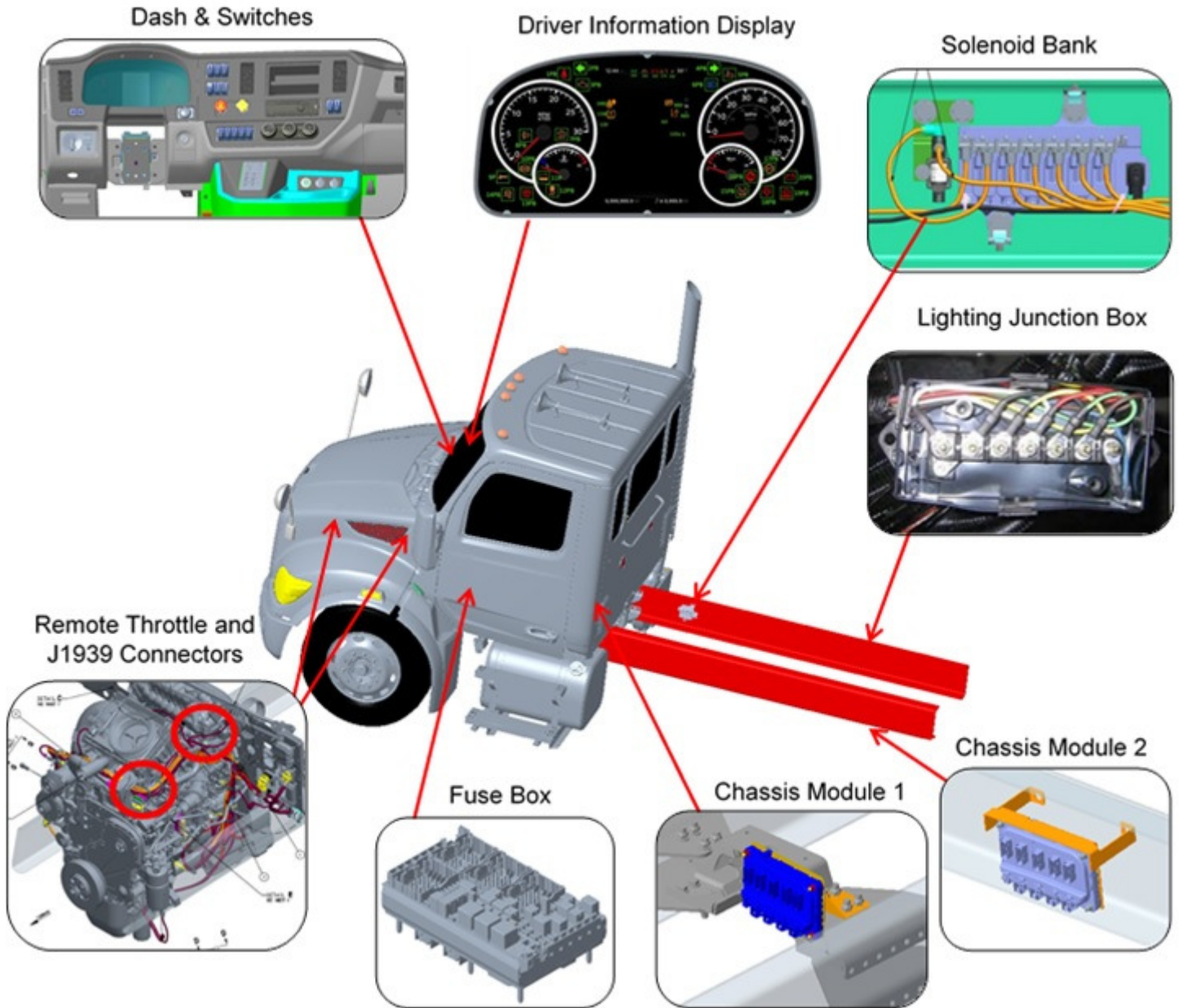

ELECTRICAL HARNESS OVERVIEW

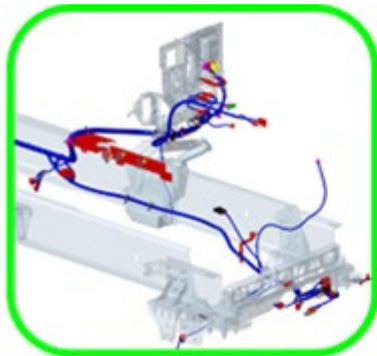

MAIN CHASSIS HARNESS

1. Connection to Firewall Bulkhead
2. Connection to Rear Chassis Harness
3. Connection to Chassis Module
4. Connection to Solenoid Bank
5. Connection to Hood Harness
6. Connection to Allison TCM

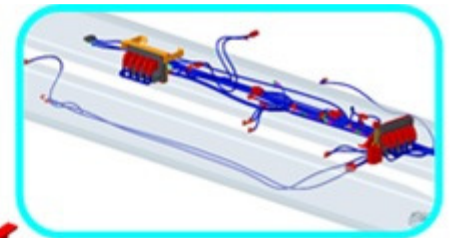

REAR CHASSIS HARNESS

1. Connection to Main Chassis Harness
2. Connection to Tail Lights

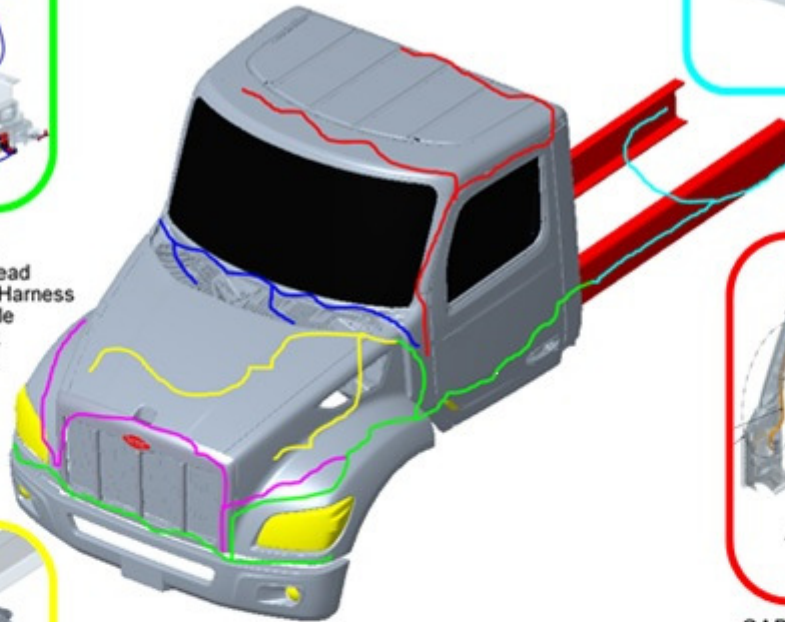

CAB ROOF HARNESS

1. Connection to Main Cab IP Harness
2. Connection to Antennas
3. Connection to Roof Lighting

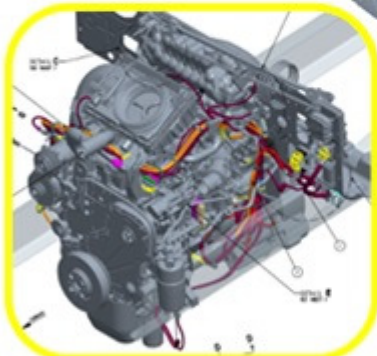

ENGINE HARNESS

1. Connection to Main Chassis Harness
2. Connection to Firewall Bulkhead
3. Connection to Starter
4. Connection to Aftertreatment Harness
5. Connection to Engine ECU



HOOD HARNESS

1. Connection to Main Chassis Harness
2. Connection to Head Lights
3. Connection to Turn Signals

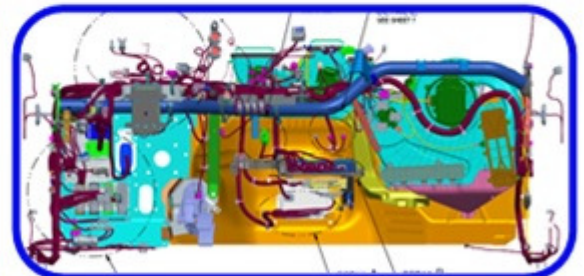

MAIN CAB IP HARNESS

1. Connection to Firewall Bulkhead
2. Connection to VECU
3. Connection to Power Distribution Center
4. Connection to Instrument Panels
5. Connection to Cab Roof Harness
6. Connection to ABS ECU
7. Connection to Master Switch Module

IN CAB CAN BASED MESSAGING CONNECTOR

RP1226 CONNECTOR

The RP1226 connector is located on the left hand side of the steering wheel behind the dash near the OBD connector. The RP1226 connector can be used for after-market telematics, ELD, body controls, and PTO controls. There will be multiple bus speeds available, K-CAN for 250kbps and S-CAN for 500 kbps. The RP1226 provides defined messages and major telematics supplier data for customer use.

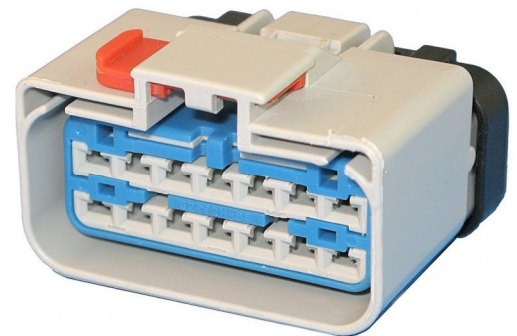
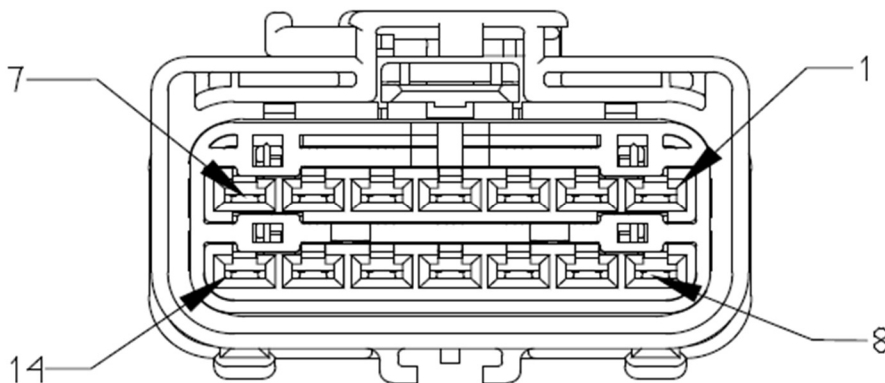
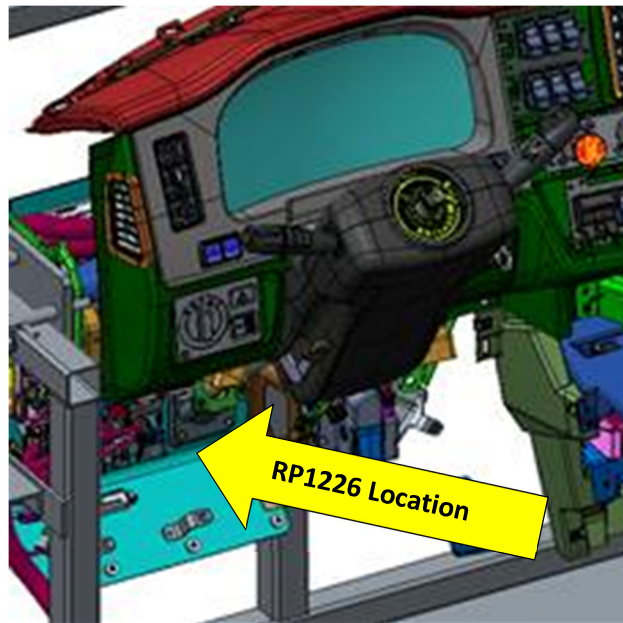

Pin	Description
1	PROTECTED POWER
2	J1939 S-CAN (+)
4	J1939 K-CAN (+)
7	IGNITION POWER
8	GROUND
9	J1939 S-CAN (-)
11	J1939 K-CAN (-)

BODY CONNECTION POINTS – MAIN CHASSIS HARNESS

ISOMETRIC VIEW

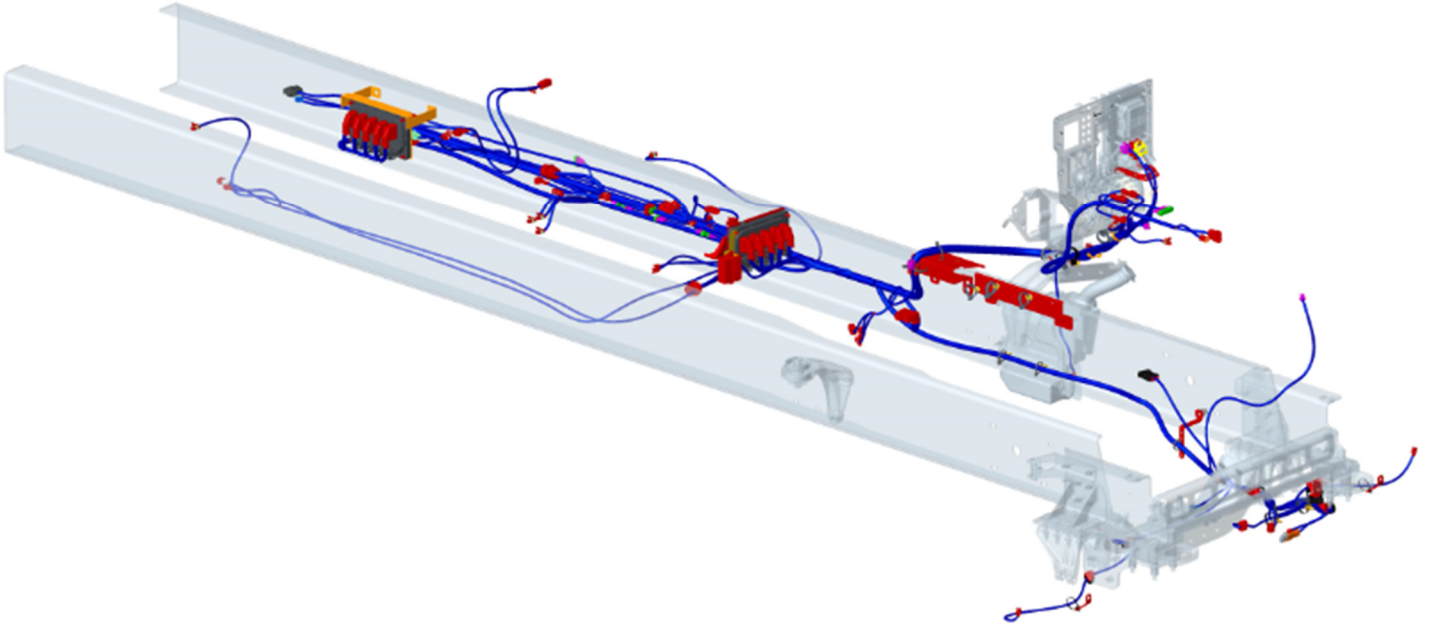

SIDE VIEW

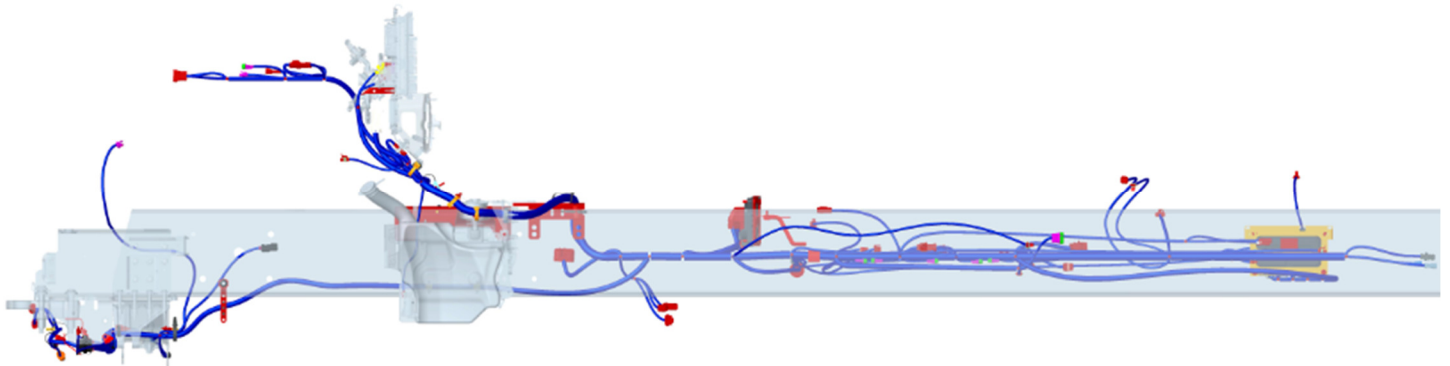

FRONT PORTION VIEW

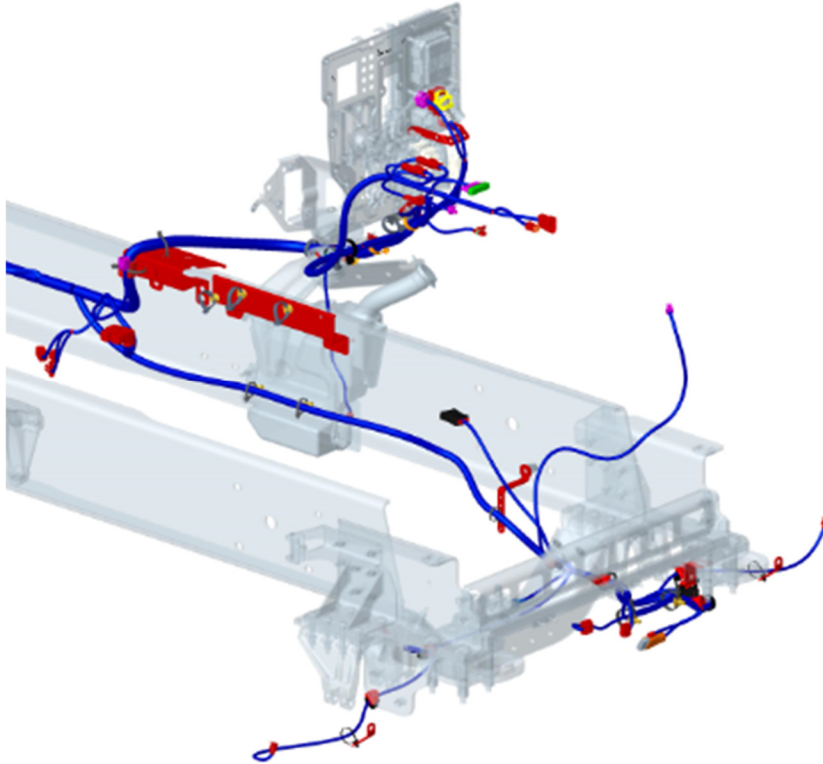

DETAIL VIEW OF ENGINE COMPARTMENT BODY CONNECTORS

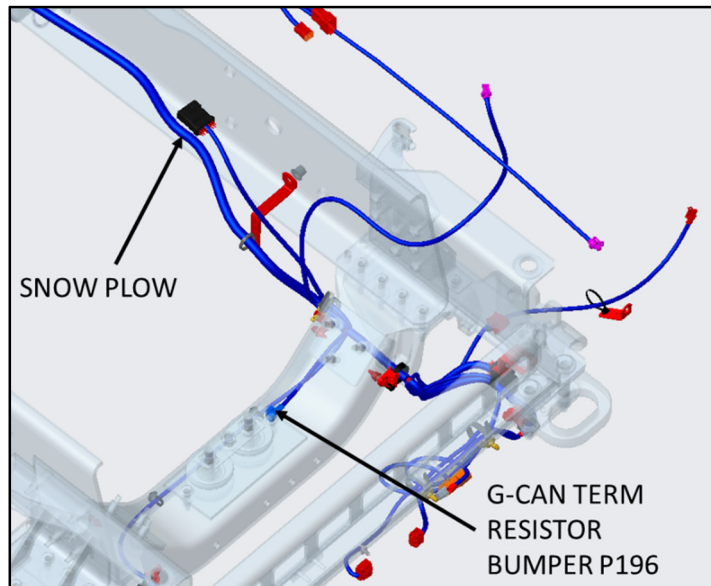

DETAIL VIEW OF ENGINE COMPARTMENT BODY CONNECTORS CONTINUED

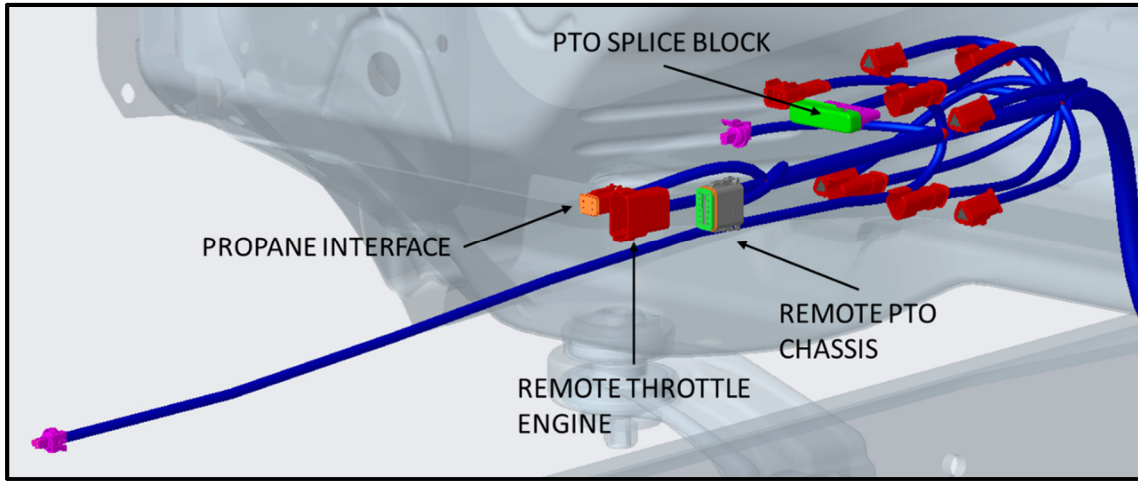

REAR PORTION VIEW

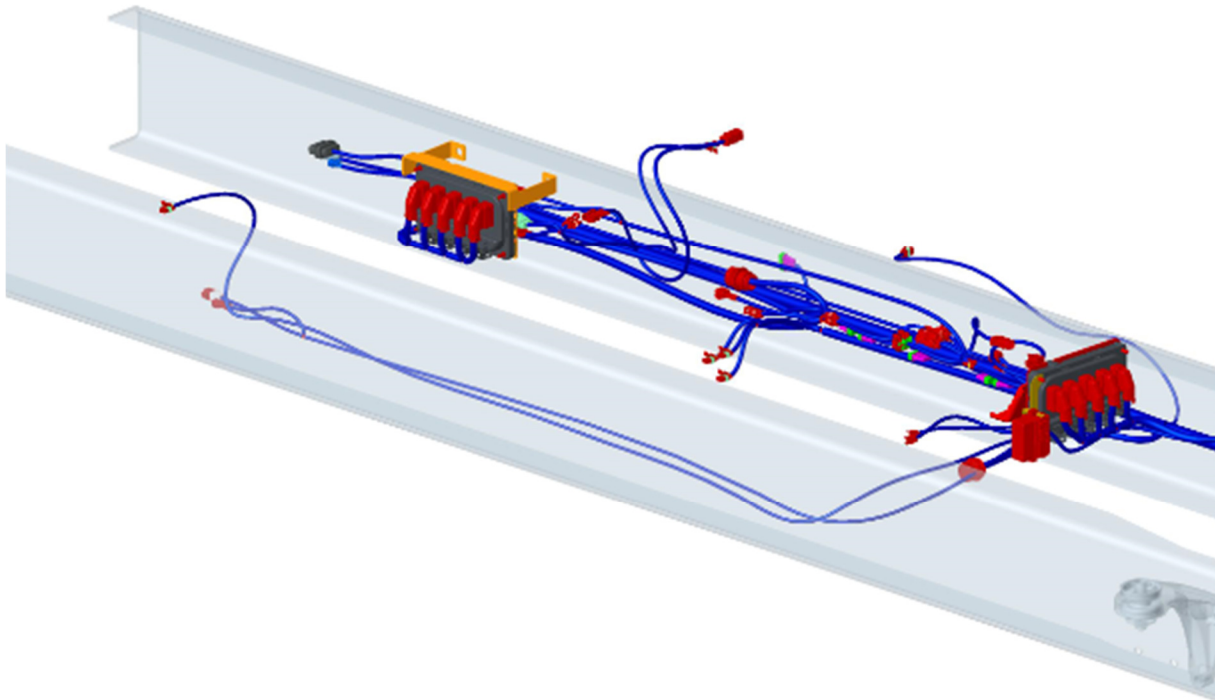

DETAIL VIEW OF BOC AND EOF BODY CONNECTORS

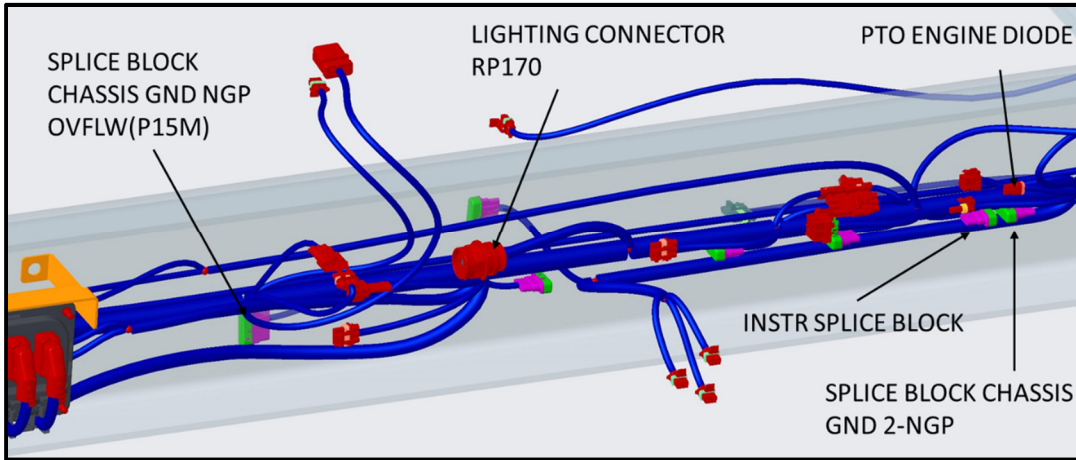

DETAIL VIEW OF BOC AND EOF BODY CONNECTORS CONTINUED

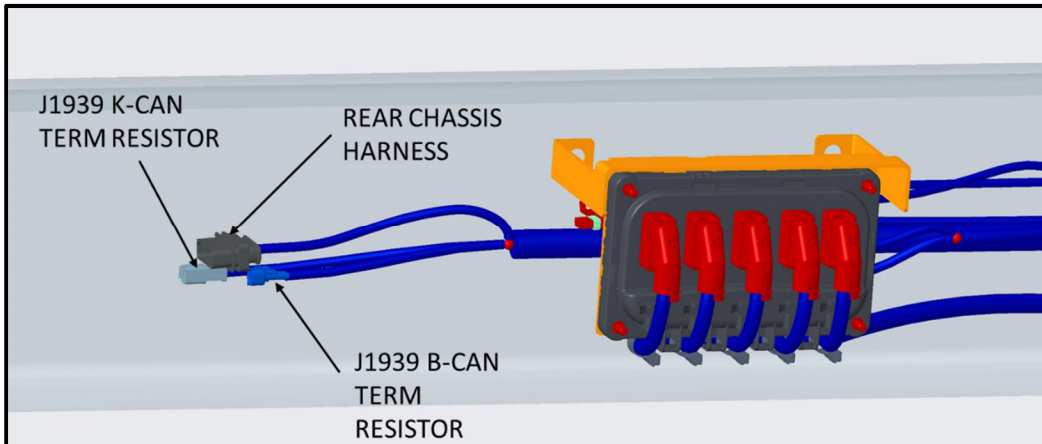

ELECTRIC ENGAGED EQUIPMENT

At the left hand forward cab mount, P198 is available for PTO controls that are electrically engaged via ground.

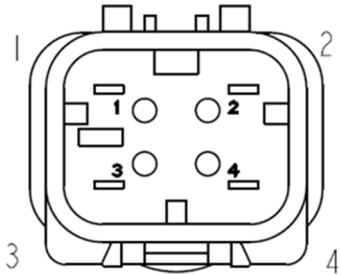

Pin	Description
1	VEHICLE GROUND
2	#1 PTO ON/OFF
3	PTO PUMP MODE SIGNAL
4	#2 PTO ON/OFF

RP170 CONNECTOR

The RP170 connector provides various pins for vehicle and trailer lamps. The connector will be located in the frame rail right behind the BOC crossmember.

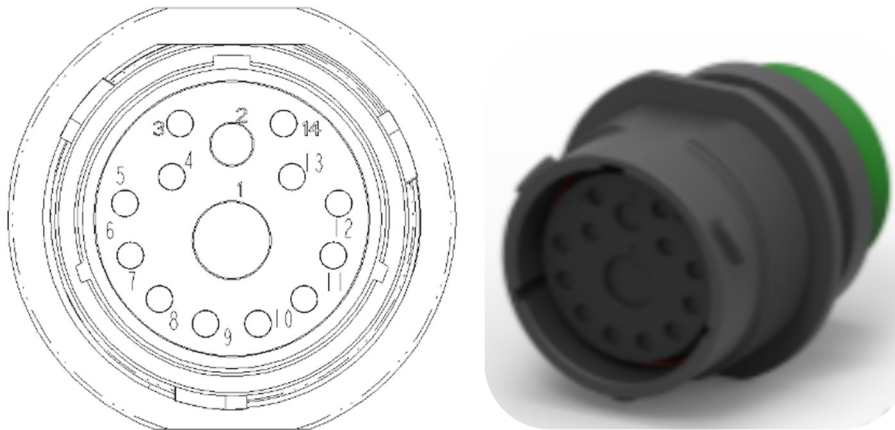

Pin	Description
1	FIREWALL GROUND
2	BACKUP LIGHTS
3	LH TURN/STOP
4	TRAILER LH TURN
5	TRAILER MARKER LAMP RELAY
6	PARK LAMPS
7	TRAILER STOP LAMPS
8	NOT USED
9	NOT USED
10	NOT USED
11	NOT USED
12	NOT USED
13	RH TURN/STOP
14	TRAILER RH TURN

ENGINE HARNESS 12 PIN CONNECTOR

Chassis must be ordered with the appropriate option to have a 12 pin connector on the engine harness. The Body IGN signal was moved off the engine harness connector, so the Chassis Harness will include the PTO layer to insert the Body IGN signal back into the 12-way connector. Signals that feed directly to the engine ECM typically will be active low signals. Connect pins 3 and 5 for simple PTO ON/OFF signal. For Remote throttle bump, you must connect pins 3 & 6. Having a momentary switch to signal ground on pins 2 and 1 will then increase/decrease engine speed. Engine speed will depend on how engine is programmed. Unless otherwise specified, engine is set by default for incremental speed increase. Full remote throttle control can be achieved with a twisted triple to pin 4, 10, and 11.

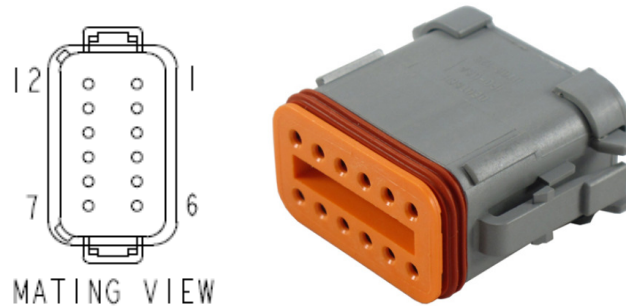

Pin	Description
1	INPUT FOR REMOTE PTO RESUME (Active Low)
2	INPUT FOR REMOTE PTO SET (Active Low)
3	SWITCH RETURN FOR CUMMINS ENGINE
4	INPUT FOR REMOTE THROTTLE SENSOR CIRCUIT (TWISTED TRIPLE)
5	PTO ENGAGED SIGNAL (LOW = ENGAGED)
6	CRUISE ON/OFF (Active Low)
7	+12V 10A BODY IGN FUSE C_A6
8	VEHICLE GROUND
9	TORQUE LIMIT INPUT (Active Low)
10	PWR SUPPLY +5V (TWISTED TRIPLE)
11	ANALOG RETURN (TWISTED TRIPLE)
12	REMOTE ACCELERATOR ENABLE

ENGINE HARNESS CONNECTION LOCATIONS

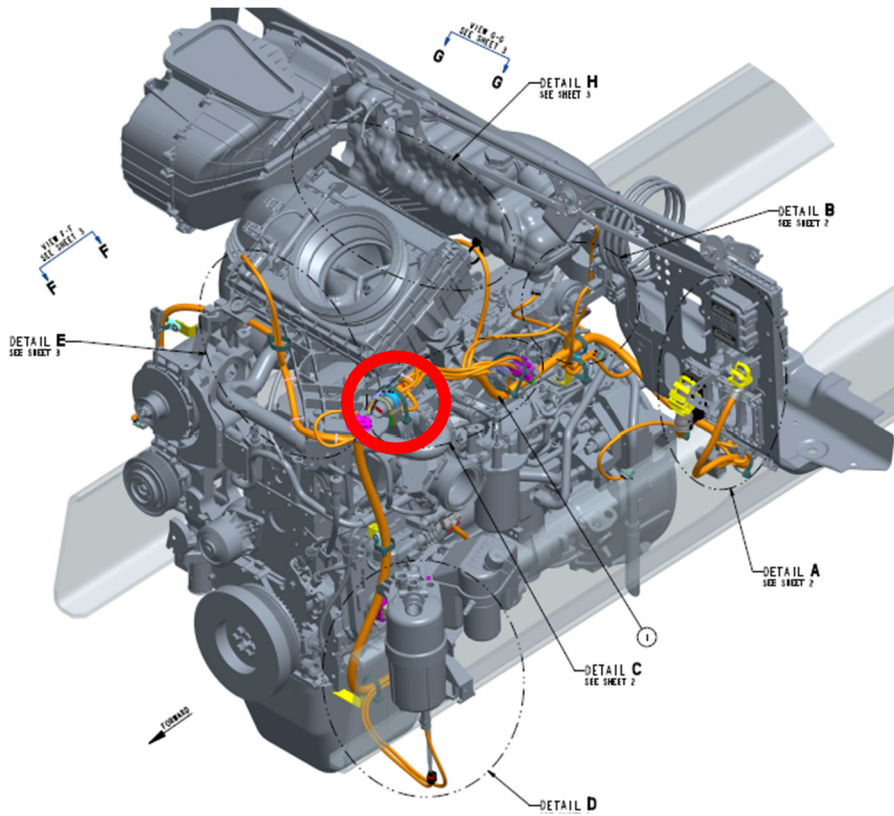

PX7 Connection location

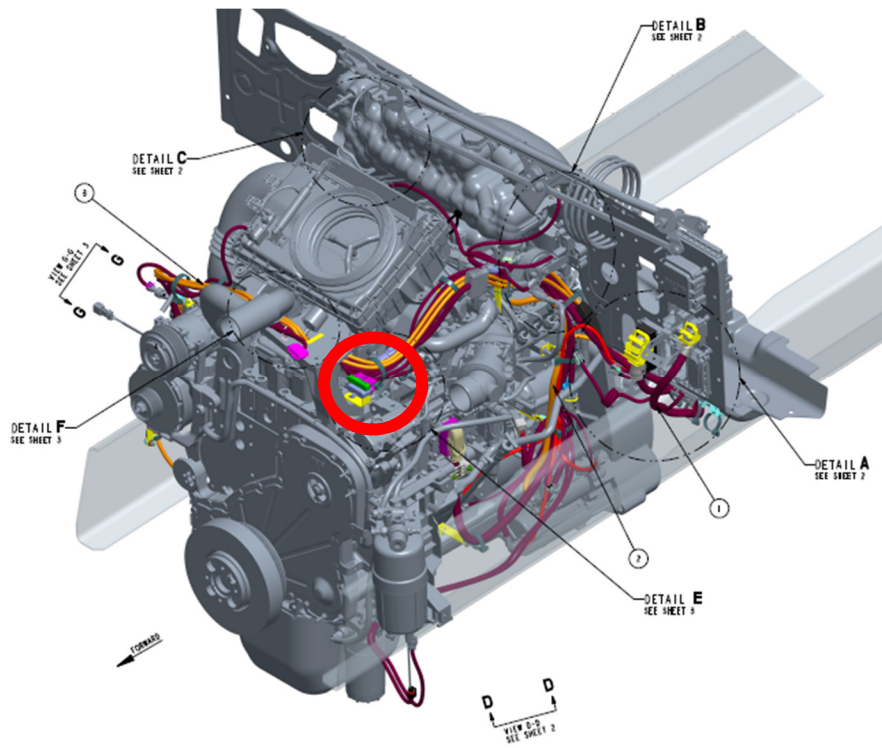

PX9 Connection location

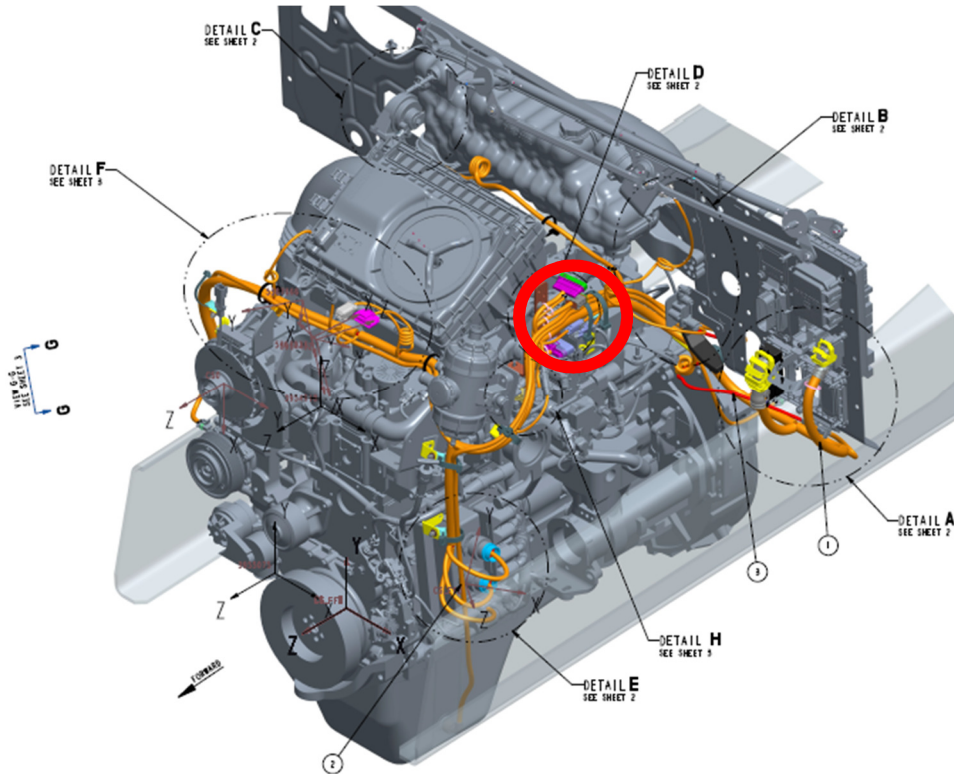

B6.7N Connection location

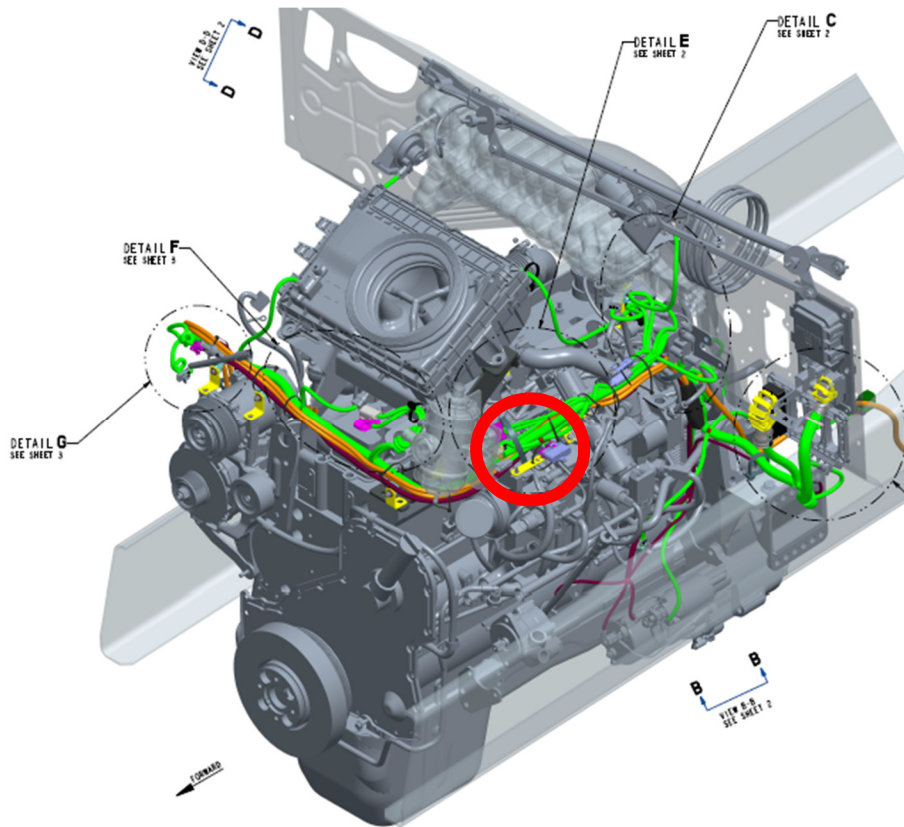

L9N Connection location

POWER DISTRIBUTION CENTER

ENGINE SIDE

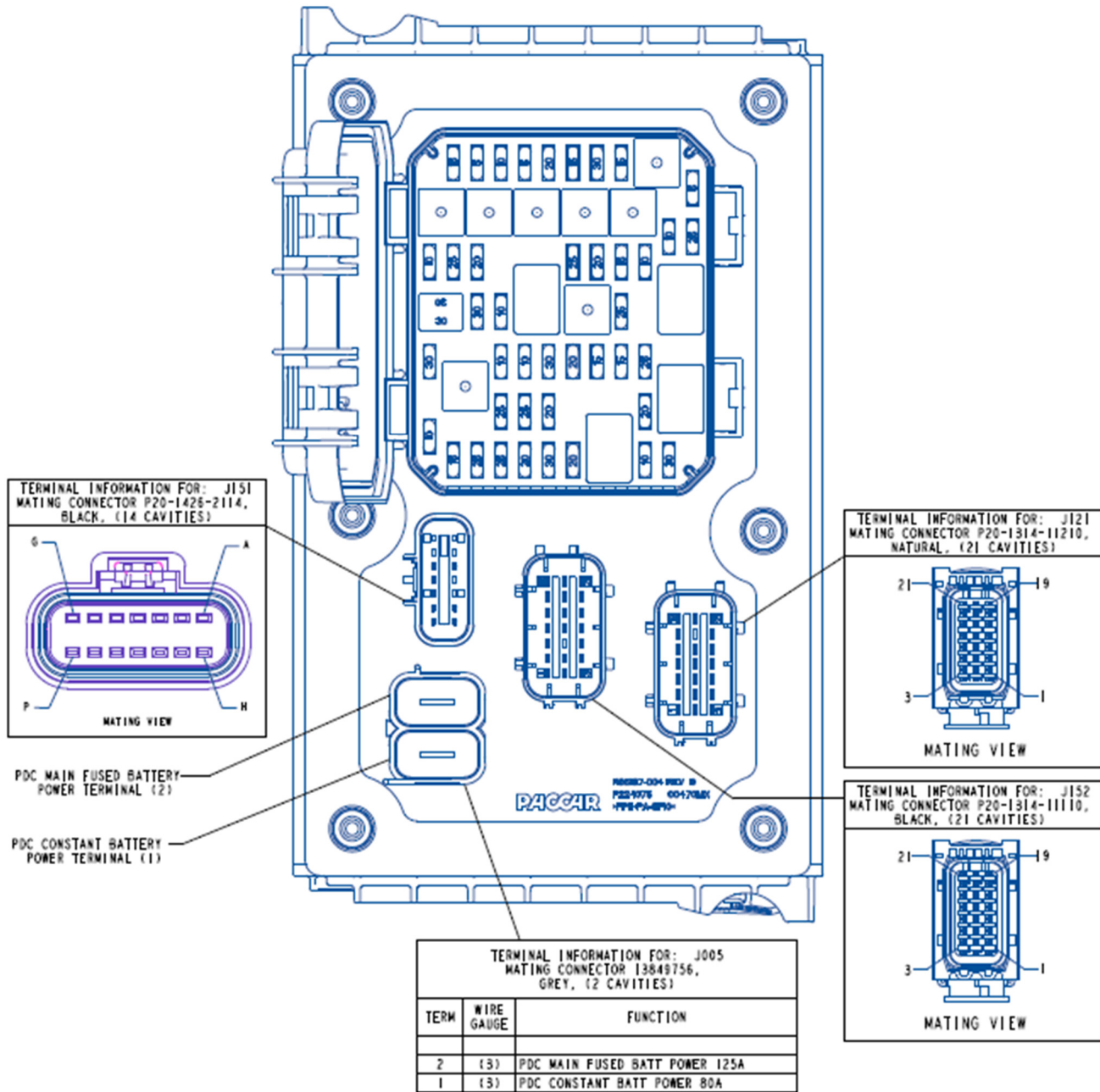

DASH SIDE

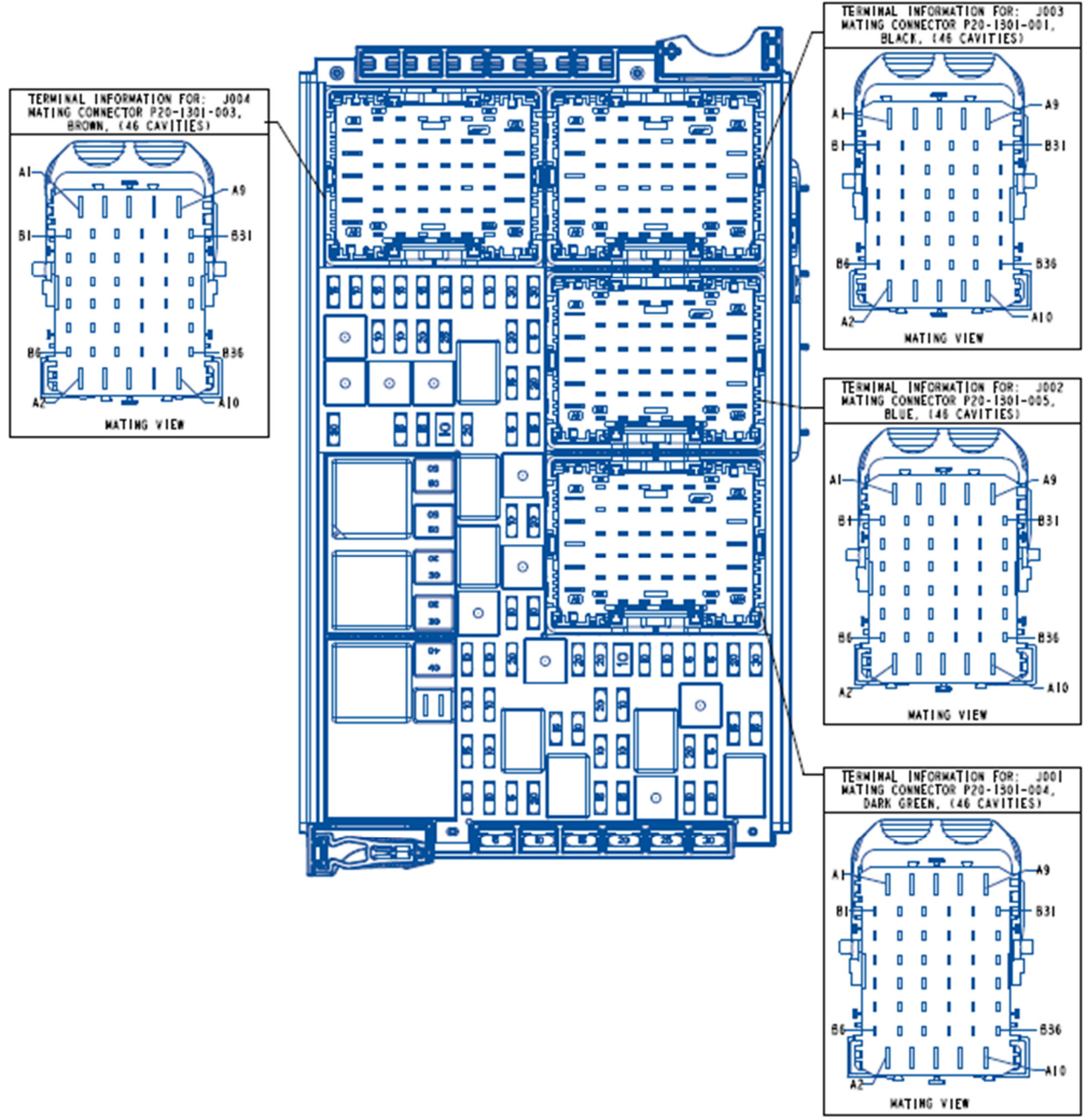

ENGINE SIDE FUSE BOX FULL CONTENT POPULATION

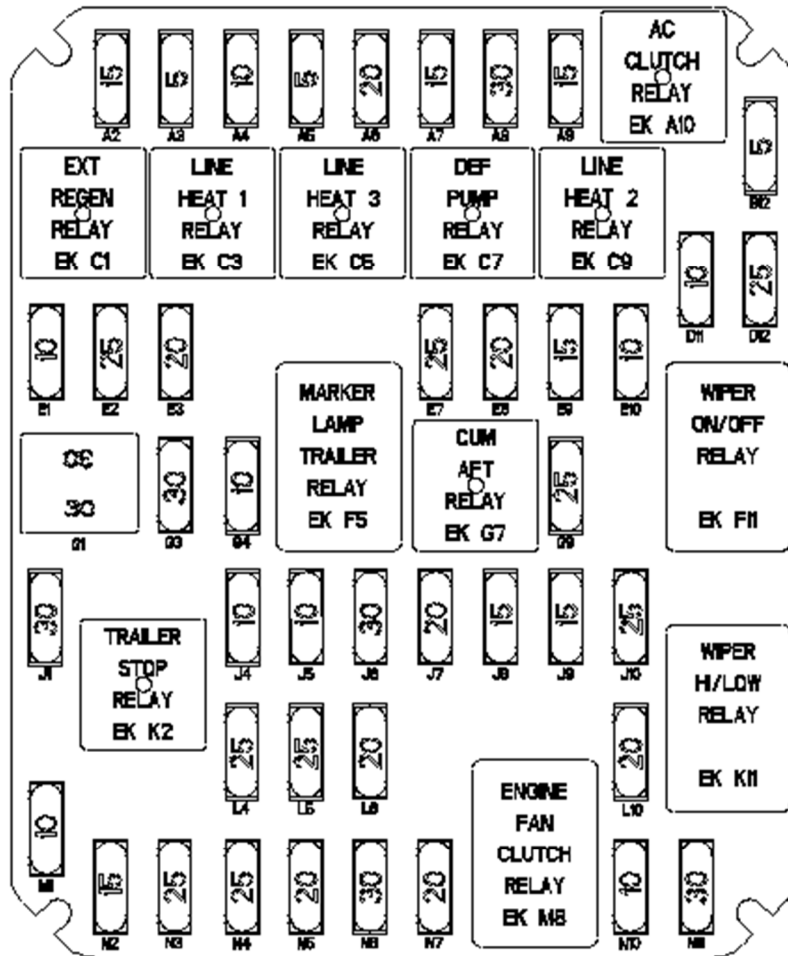

FUSE ID	AMP	DESCRIPTION
A2	15A	LINE HEAT 1 (PRESSURE)
A3	5A	ENGINE ECU WAKE (ENG SIDE)
A4	10A	CHASSIS MOD/UE P/S
A5	5A	LINE HEAT 3 (SUCTION)
A6	20A	CHASSIS MOD SECONDARY F4
A7	15A	DEF PUMP
A8	30A	CAB ABS
A9	15A	LINE HEAT 2 (BACKFLOW)
B12	5A	HVAC HEAD PWR/DOOR A JAR
B11	10A	AC CLUTCH RELAY PWR
B12	25A	WIPER MOTOR
E1	10A	CAB ABS PWR- 10A IGN
E2	25A	QUALCOMM TRLR TRACKS
E3	20A	EXT REGEN/LNG-CNG IGN
E7	25A	CHASSIS MOD SECONDARY F6
E8	20A	SPARE CONSTANT PWR 1
E9	15A	ICM PWR
E10	10A	VECU BATT PWR 1
G1	30A JCASE	HVAC BLDC MOTOR
G3	30A	SPARE BATT 7
G4	10A	ALLISON/AUTO/ULTRASHIFT
G9	25A	FRAME FUEL HEATER
J1	30A	SPARE BATT 8
J4	10A	ACC RADAR/TPMS
J5	10A	BACKUP LAMP
J6	30A	TRAILER MARKER RELAY PWR
J7	20A	HDLP LH HI/BRAKE
J8	15A	AFT/NOX/VISFD
J9	15A	CUM AFT
J10	25A	WIPER ON CTL
L4	25A	CHASSIS MOD PRIMARY F5
L5	25A	CHASSIS MOD PRIMARY F6
L6	20A	CHASSIS MOD PRIMARY F7
L10	20A	TRICAN/DEF CTL/DOSER
M1	10A	MUX SOL BANK LT
N2	15A	TRAILER STOP LP
N3	25A	RH HDLP LG/DRL/PARK
N4	25A	RH HDLP HI/FOG/DRL
N5	20A	LH HDLP LG/DRL/PARK
N6	30A	AUTO TRANS
N7	20A	CHASSIS MOD SECONDARY F5
N10	10A	FAN CLUTCH PWR
N11	30A	CUM ECM PWR

DASH SIDE FUSE BOX FULL CONTENT POPULATION

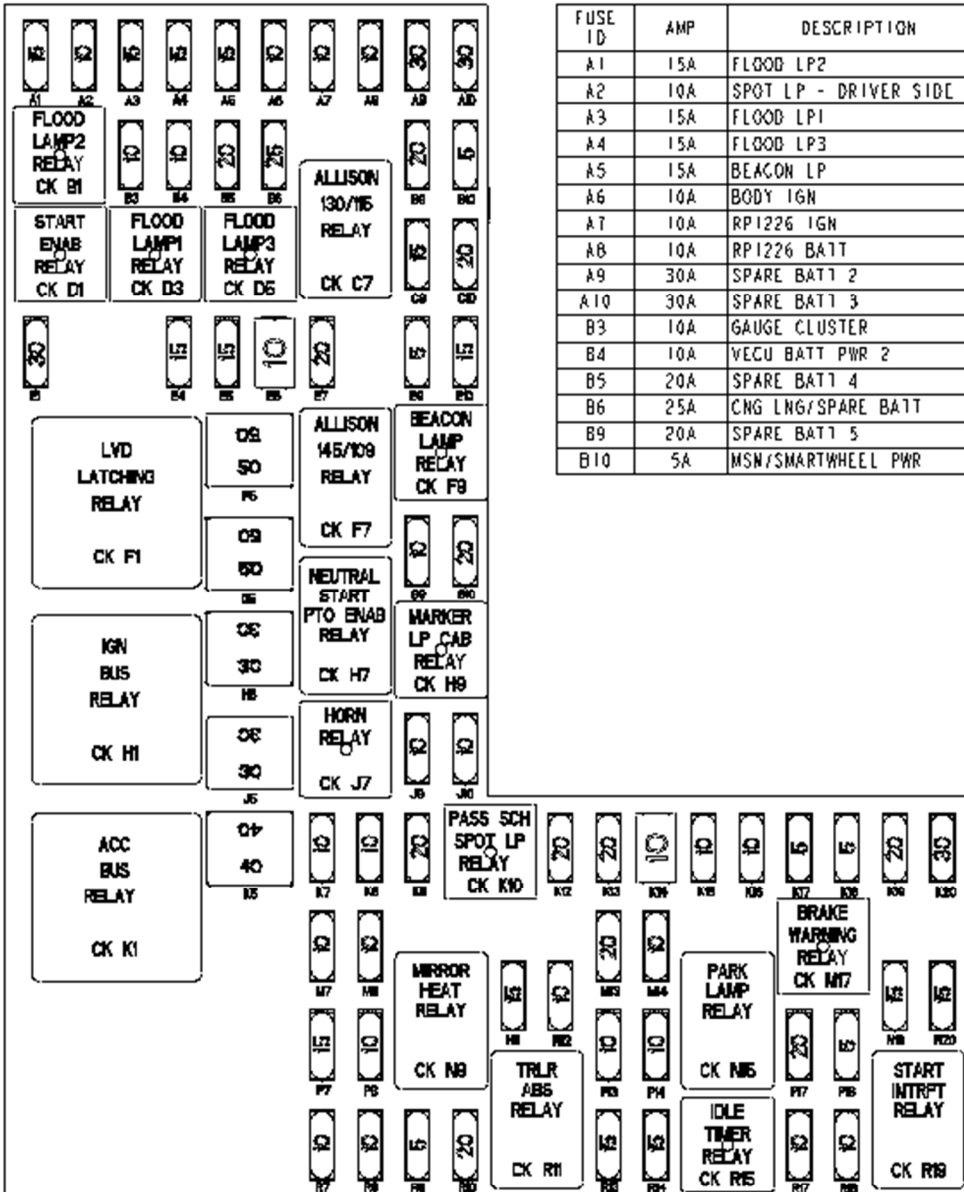

FUSE ID	AMP	DESCRIPTION	FUSE ID	AMP	DESCRIPTION
A1	15A	FLOOD LP2	C9	15A	CB/RADIO PWR
A2	10A	SPOT LP - DRIVER SIDE	G10	20A	CHASSIS MOD SECONDARY F1
A3	15A	FLOOD LPI	E1	30A	SPARE ACC 3
A4	15A	FLOOD LP3	E4	15A	POWER PORT 1
A5	15A	BEACON LP	E5	15A	POWER PORT 2/CIGAR LTR
A6	10A	BODY IGN	E6	10A	CAB DOME LP *
A7	10A	RP1226 IGN	E7	20A	SPARE LVD 1
A8	10A	RP1226 BATT	E9	5A	TRACTOR STOP LAMPS
A9	30A	SPARE BATT 2	E10	15A	CHASSIS MOD SECONDARY F2
A10	30A	SPARE BATT 3	F5	50A JCASE	HYD ABS PUMP SUPPLY
B3	10A	GAUGE CLUSTER	G5	50A JCASE	HYD ABS BOOST MTR PWR
B4	10A	VECU BATT PWR 2	G9	10A	EOAS
B5	20A	SPARE BATT 4	G10	20A	TELEMATICS/QCOM BATT
B6	25A	CNG LNG/SPARE BATT	H5	30A JCASE	RH DOOR MOD
B9	20A	SPARE BATT 5	J5	30A JCASE	LH DOOR MOD
B10	5A	MSN/SMARTWHEEL PWR	J9	10A	DIAGNOSTIC POWER
			J10	10A	TCM BATT
			K5	40A JCASE	TRAILER E-BRAKE
			K7	10A	HORN RELAY PWR
			K8	10A	CAB MARKER RELAY PWR
			K9	20A	SPARE BATT 6
			K12	20A	HYD ABS AIR SEAT
			K13	20A	SPARE IGN 1
			K14	10A	ETRAC VALVE *
			K15	10A	VECU STOP LAMP SW
			K16	10A	PARK LP - CAB PWR
			K17	5A	VECU / DIGITAL DISPLAY IGN PWR
			K18	5A	RH STALK/SHIFTER
			K19	20A	CHASSIS MOD SECONDARY F3
			K20	30A	TRAILER HOT LINE
			M7	10A	SPLICE FEED IGN
			M8	10A	RH HEATED SEAT
			M13	20A	SPARE IGN 2
			M14	10A	SIGN LAMP SW
			N11	15A	RH MIRROR HEAT
			N12	10A	LH HEATED SEAT
			N19	15A	LH MIRROR HEAT
			N20	15A	PARK LP - TRLR PWR
			P7	15A	AIR DRYER
			P8	10A	PRIMARY SHIFTER BATT 1
			P13	10A	KEY SW/GAUGE CLUSTER
			P14	10A	DIGITAL DISPLAY
			P17	20A	SPARE BATT 1
			P18	5A	HVAC HEAD ACC
			R7	10A	SPARE ACC 6
			R8	10A	REMOTE DIAG
			R9	5A	VECU ACC PWR
			R10	20A	SPARE ACC 1
			R13	15A	SPARE ACC SW 3/4/5
			R14	15A	SPARE ACC SW 1/2
			R17	10A	SPARE ACC 2
			R18	10A	RADIO WAKE UP

* DENOTES OPTIONAL POLYSWITCH

CHASSIS MODULE

Chassis modules are replacing the legacy NAMUX3 chassis node. Chassis modules are slave I/O drivers controlled by the VECU. Chassis modules have expanded functionality and option platform growth in comparison to the previous chassis node. Chassis modules have built-in protections to prevent internal damage, are capable of detecting faults, and storing DTC's. Chassis modules can also be diagnosed through the DAVIE service tool.

There are three variants of chassis module: the Primary (CMP), Primary LITE (CMLITE), and Secondary (CMS). Depending on how the truck is ordered, a CMP or CMLITE will be installed. Like the heavy duty variant, certain options would require medium duty trucks to have a CMS installed in addition to a CMP or CMLITE. MD trucks will have a maximum of two chassis modules installed, depending on order configuration. The primary chassis module will be mounted under the back of the cab on the top left hand side of the back of cab cross-member. The secondary optional chassis module will be bracket mounted inside the LH frame rail a few feet behind BOC.

CHASSIS MODULE LOCATIONS

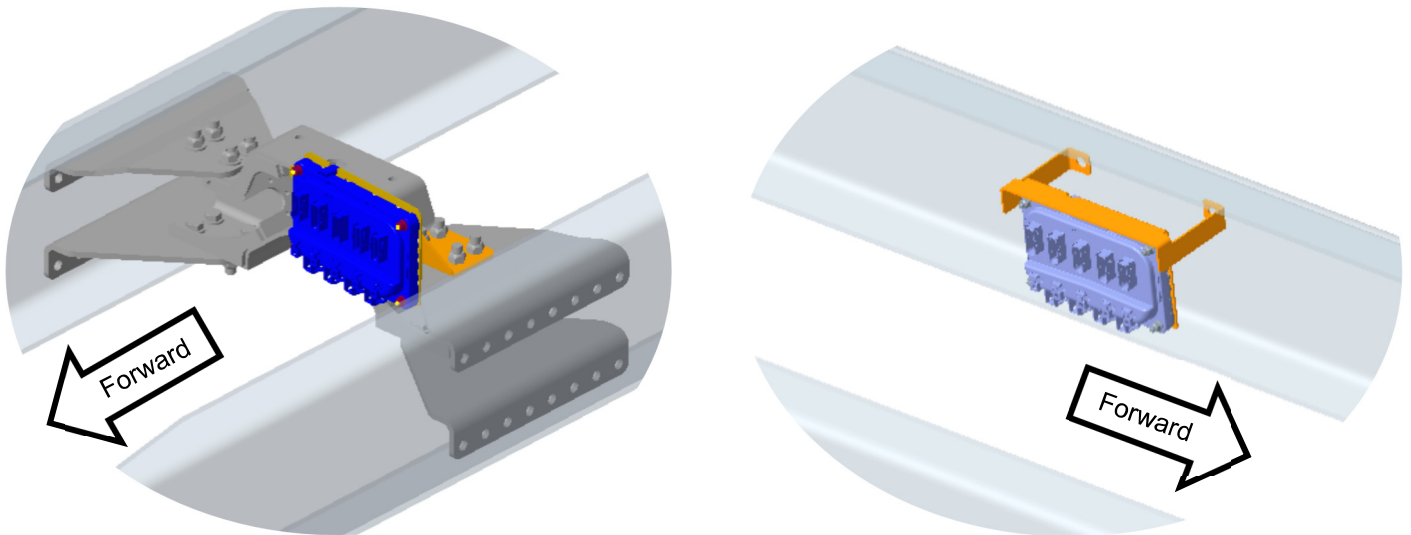

TOP VIEW OF CHASSIS MODULE LOCATIONS

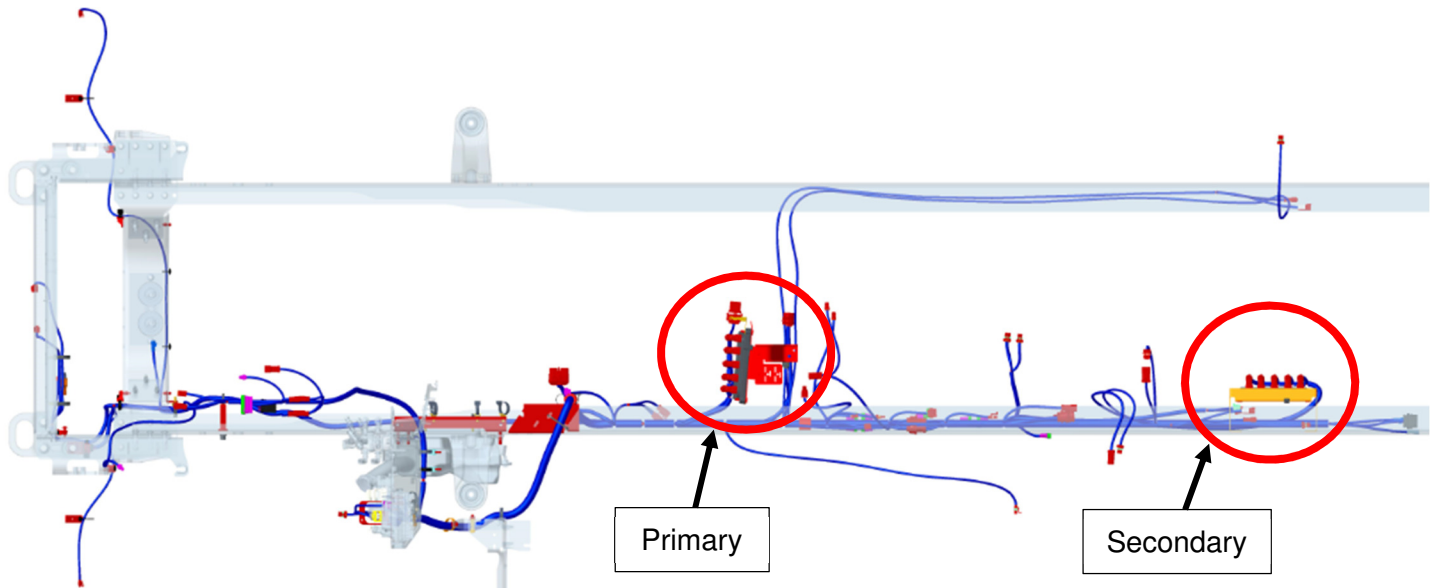

CHASSIS MODULE FUNCTION DESIGNATIONS**PRIMARY AND PRIMARY LITE CHASSIS MODULE**

- Exterior Lighting: Headlamps, Park/Tail, Turn, Brake, DRL, Fog Lights*, Reverse etc.
- Axle Temperature Sensor Inputs* Front Rear and Rear
- Ammeter Sensor Input
- Secondary Kingpin Release Solenoid Control
- Primary/Secondary Fuel Level Sensors
- Lift Axle Air Solenoid Controls 1st, 2nd
- Primary Transmission Neutral Position Switch
- Remote PTO/Throttle Control Inputs
- J-CAN Multiplexed EOA Solenoid Bank Control
- Fuel Filter Gauges
- Main Transmission Oil Temp

* = Functionality is depopulated on CMLITE Module

SECONDARY CHASSIS MODULE

- External Notification of DPF Regeneration
- AT1202 Aux Trans Neutral Switch
- Axle Temperature Gauges Center Rear
- Lift Axle Air Solenoid Controls 3rd , Tag (Rocker Panel Controls)
- NAMCO/FABCO Split shaft PTO/Transfer Case Sensors
- Aux Transmission Temperature Sensor
- Split Shaft PTO Temperature Sensor
- Fuel Temp Sensor (Auto Start)
- Chicken/Panel Lamps, Snow Plow Lamp
- ISO 3731 Spare Outputs
- B-CAN
- Auto Start/Stop Hood Tilt Switch
- City Horn

FUSE GROUPS

PRIMARY CHASSIS MODULE

Fuse Group	Function
F1	Electric Over Air Solenoid Kingpin Release
	Main Beam (aka High Beam) - LH
	Tractor Direction Indication and Hazard Lights - RH Rear (Brake Lamps Also)
F2	Tractor Direction Indication/Hazard/DRL Lights - LH Front
	Front Tractor Position lights (Park Lamps)
	Tractor Direction Indication Hazard Side Turn Indicator LH Front
	Dipped Beam (aka Low Beam) - LH
F3	Lift Axle #2 Solenoid
	Daytime Running Lights (DRL) Peterbilt - LH
	Tractor Direction Indication/Hazard/DRL Lights - RH Front
	Tractor Direction Indication Hazard Side Turn Indicator RH Front
	Dipped Beam (aka Low Beam) - RH
F4	Daytime Running Lights (DRL) Peterbilt - RH
	Main Beam (aka High Beam) - RH
	Fog/Driving Lights (Front) 1st Set
F5	Reverse Warning (aka Backup Alarm)
	(Rear) Direction Indication and Hazard Lights - LH Trailer
F6	Rear Tractor Position lights (Park Lamps)
	Reverse Lamps
	Tractor Direction Indication and Hazard Lights LH Rear (Brake Lamps Also)
F7	LVD Bipolar Output 1
	LVD Bipolar Output 2
	Lift Axle #1 Solenoid
	(Rear) Direction Indication and Hazard Lights - RH Trailer

SECONDARY CHASSIS MODULE

Fuse Group	Function
F1	Work Lights 1st Set (Frame mounted Flood Light Options without pass-through grommet)
F2	Aftertreatment External Notification
F3	Sky/Auxiliary lights
	Snowplow Lamps OR Dual Station
F4	Lift Axle #3 Solenoid
	Trailer Options - ISO 3731/Spare OR Additional 4/6/7-Way Trailer Connections OR Berg Box
F5	Lift Axle #4 (Tag) Solenoid
	Trailer Options - ISO 3731/Spare OR Additional 4/6/7-Way Trailer Connections OR Berg Box
F6	Trailer Options - Trailer Dump Gate Coiled BOC OR Configurable Output
	Trailer Options - ISO 3731/Spare OR Additional 4/6/7-Way Trailer Connections OR Berg Box

VECU

Fuse Group	Function
G1	Peterbilt Driving Lights
	Inside/Outside Air Filter Control
	Starter Interrupt / Start Enable Relay Control
	Mirror Heat Relay
	Cab Dome Lamp
	Sleeper Dome Lamp
	Trailer Marker/Clearance Lamps
G2	Recirculating Header Fan - Low Speed
	Trailer Hotline Relay
	Work Lights (Flood Lamps) 2
	Work Lights (Flood Lamps) 3
	Allison MTD PTO Controls - PTO 2
	Allison MTD PTO Controls - PTO 1
	Passenger Spot Lamp
	Work Lights (Flood Lamps) 1
	Beacon/Strobe
	Trailer Brake Lamps
	Trailer/Cab Park Lamps
	Recirculating Header Fan - High Speed
	Digital Vision System – Mirrors (DVS-M)
	Start Signal
	Right Hand Steer
	LED Headlamps Heater
	PTO Engaged Output for PTO Hour Meter and PTO Telltale
Footwell Lamp	
G3	Cab Marker/Clearance Lamps Relay Output
	Washer Pump Control
	Auxiliary Lamps/ Chicken Panel Lamps
	MCS (Power)
G4	Dash PWM Backlighting
	Dash Illumination 2

ELECTRIC OVER AIR SOLENOIDS

Air solenoids are devices that translate the electrical signal into physical functions that controls the air pressure in various circuits. The air solenoids are mounted to a bracket outside the cab. The solenoids are designed to stack on each other so that they share a common air supply which reduces the amount of air lines on the vehicle.

The aftermarket installer/final vehicle manufacturer needs to decide what type of valve to install and ensure that the documentation to the operator provides them with enough understanding of how the customized switches work.

SOLENOID BANK DIAGRAM

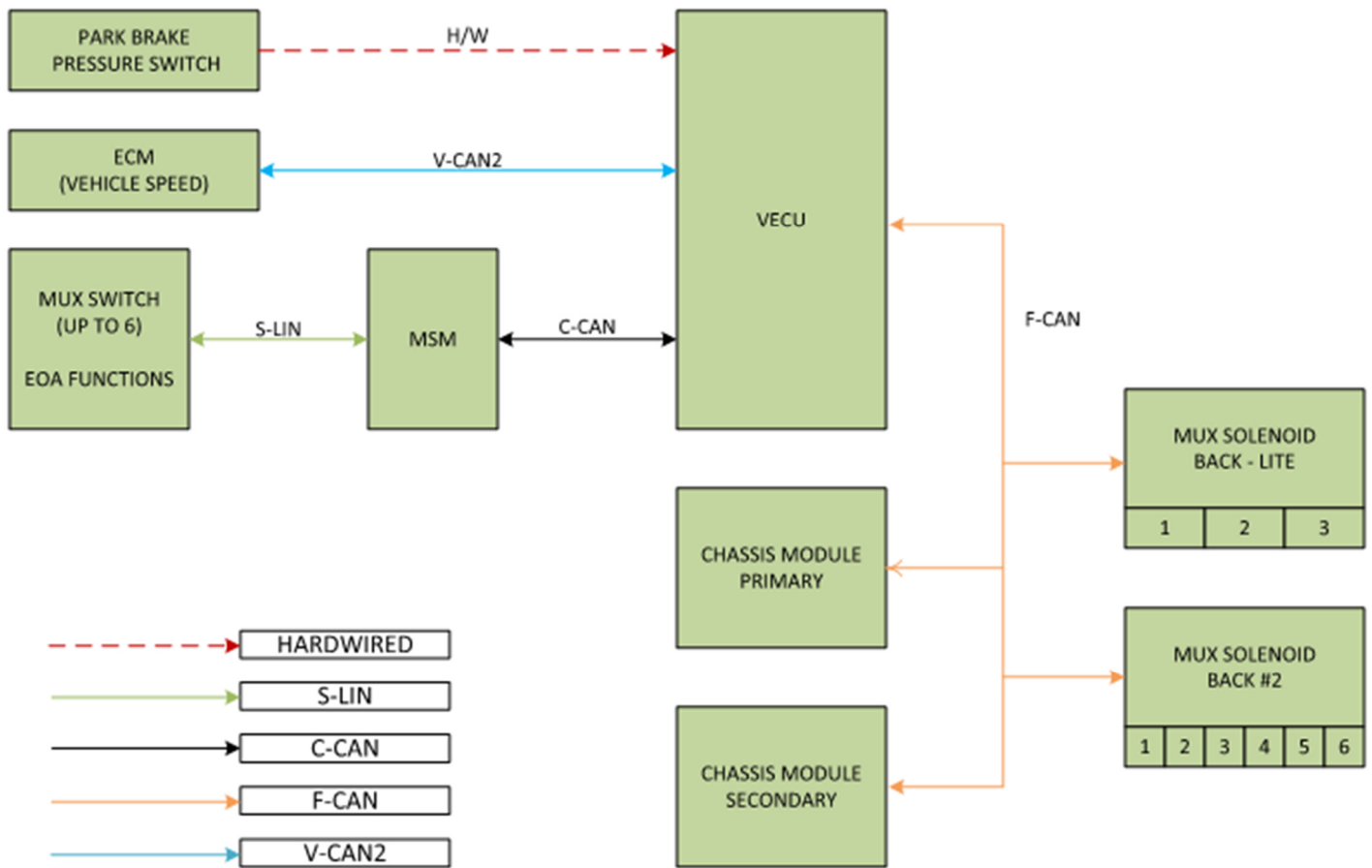

SOLENOID OVERVIEW LAYOUT

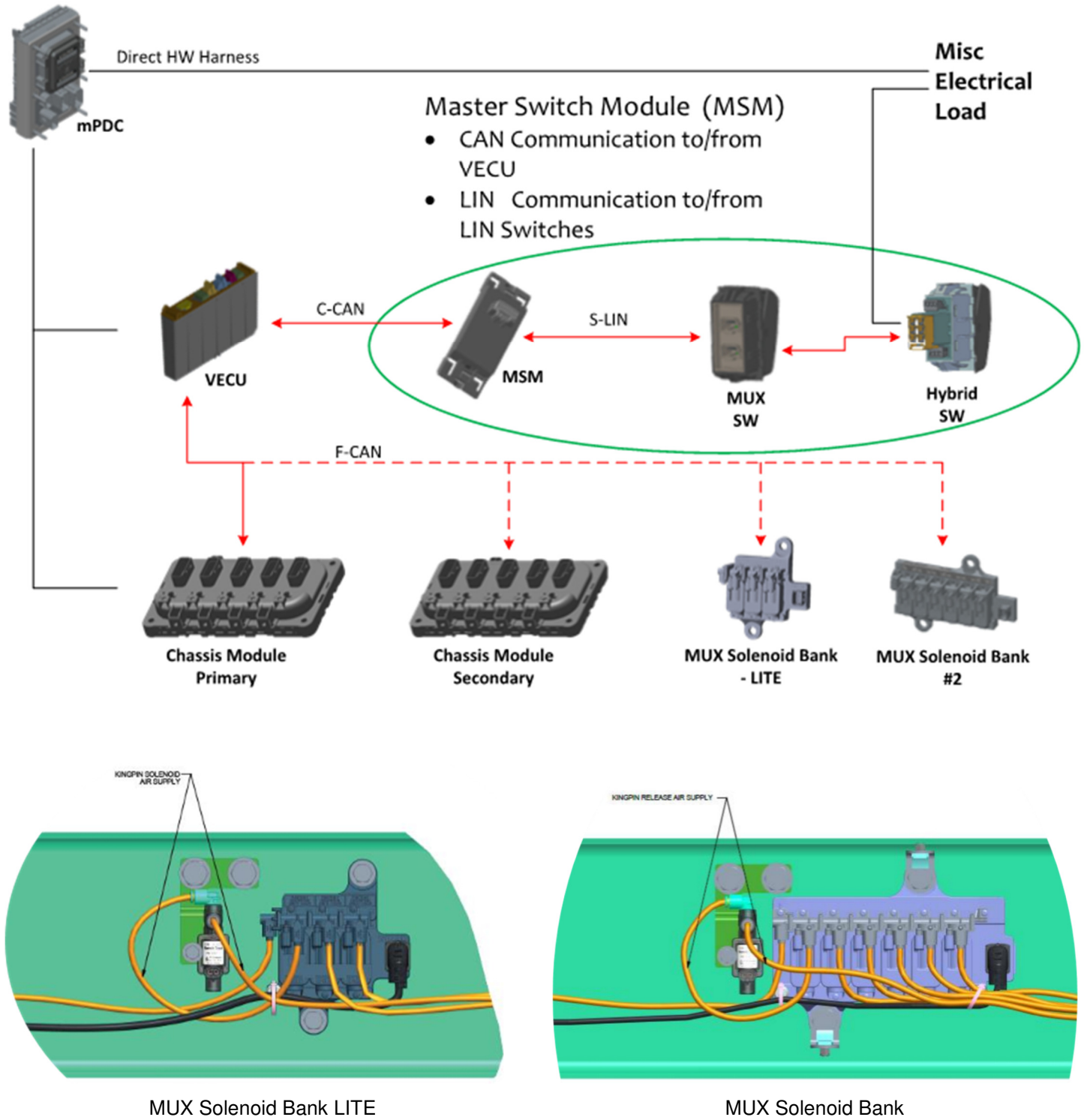

MUX SOLENOID BANK LITE FRAME MOUNTING LOCATION

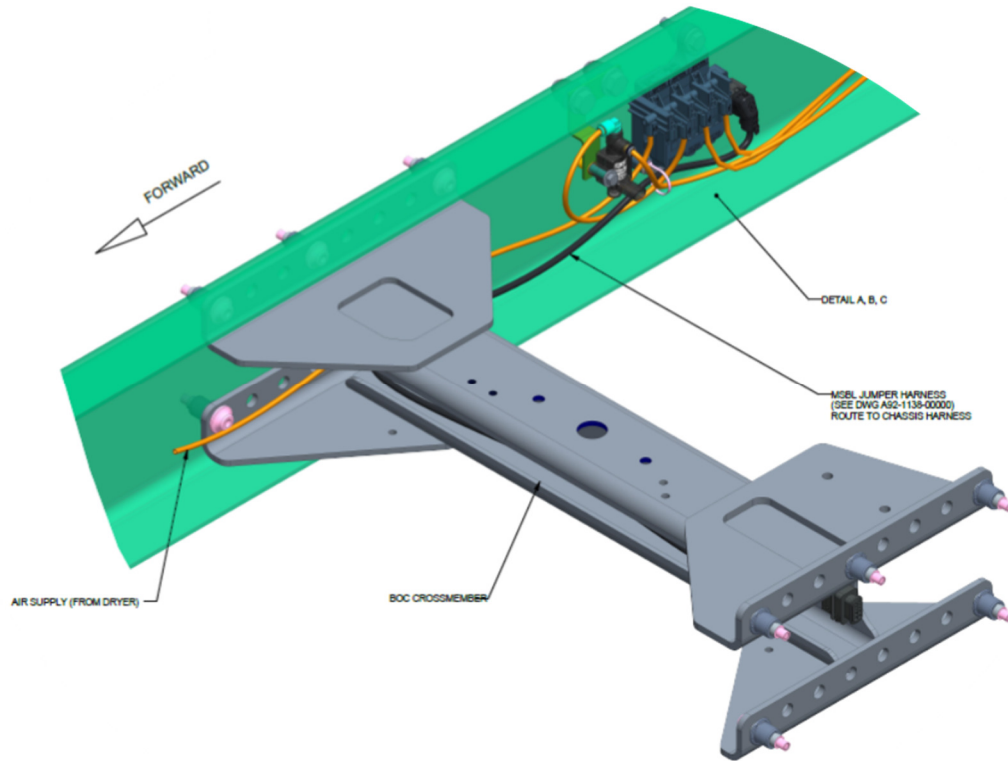

MUX SOLENOID BANK FRAME MOUNTING LOCATION

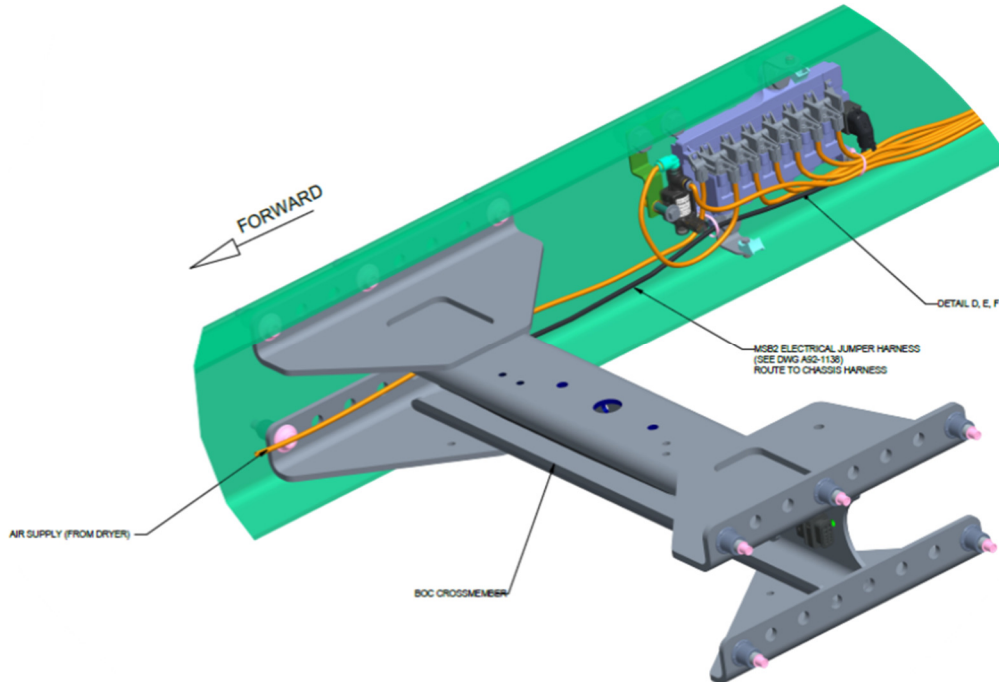

Note: If the chassis has both a lite and full solenoid bank they will be mounted side-by-side in the RH rail.

SWITCHES

SWITCH OVERVIEW LAYOUT

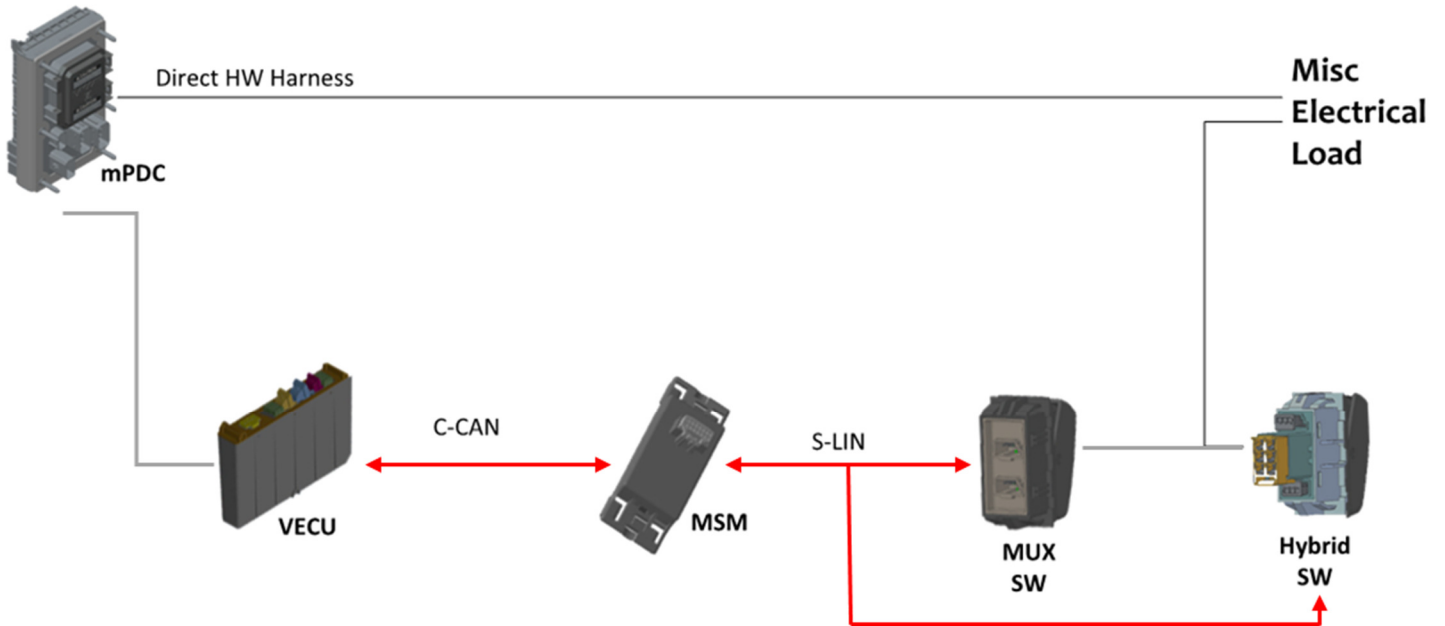

Multiplexing = shorter wire bundles, improved diagnostics, and greater driver feedback. Safety critical switches use hybrid switch with hardwire for redundancy. The switches are less expensive with fewer wires behind the dash and on chassis. The switches are self-diagnosable to improve troubleshooting with DAVIE.

- Master Switch Module (MSM)
- LIN Communication to/from Switches
- CAN Communication to/from VECU

SPARE SWITCHES

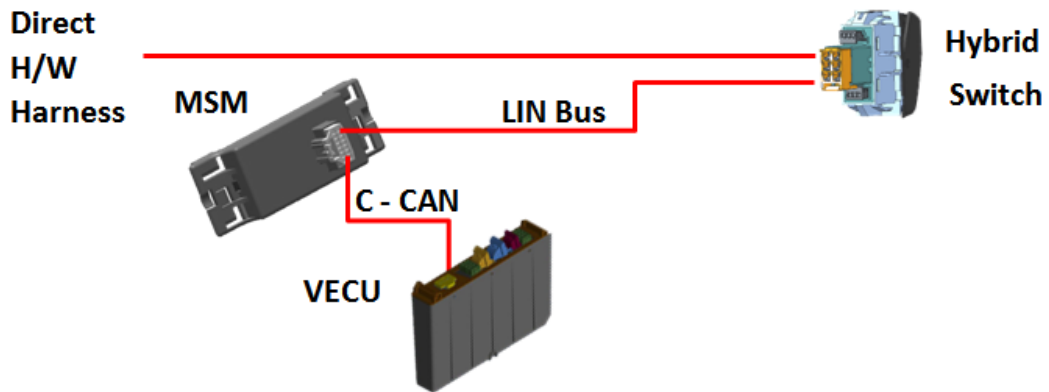

Spare switches offer customers and body builders a convenient way to control power and air to various sources, like a body or trailer. They should be flexible and easily configurable to meet the vast and unique needs of body builders. The spare switches, along with all hybrid switch variants, are rated to 15 A of current.

SWITCH RELEARN PROCESS

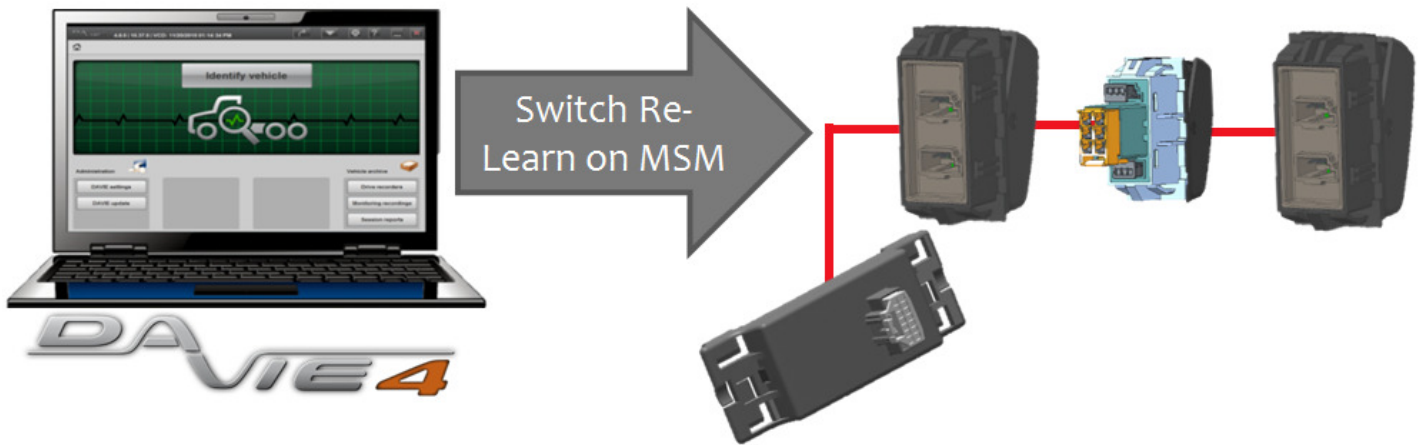

Switch replacement installation instructions:

1. Turn off the engine and all switches
2. Remove dash panel
3. Unplug LIN jumpers from the original existing switch
4. Remove original switch
5. Replace the old switch with the new switch
6. Reconnect LIN jumpers into the replacement switch
7. Reinstall the dash panel
8. Open DAVIE application
9. Select the "Repair Support" tab.
10. Select the "Driver Environment" tab
11. Select the "Learn Dash Switches"
12. Run "Quick Check"
13. Clear Inactive DTCs (Diagnostics trouble code) from MSM
14. Finished

New switch installation instructions:

1. Turn off the engine and put all switches into the off position
2. Remove the dash panels
3. Remove the switch blank
4. Add the new switch into the dash panel
5. Connect the LIN jumper between the last open switch to the newly installed switch
 - a. Part Number S92-1127-0125
6. Reinstall the dash panel
7. Open DAVIE application
8. Select the "Repair Support" tab.
9. Select the "Driver Environment" tab
10. Select the "Learn Dash Switches"
11. Run "Quick Check"
12. Clear Inactive DTCs (Diagnostics trouble code) on the MSM
13. Finished

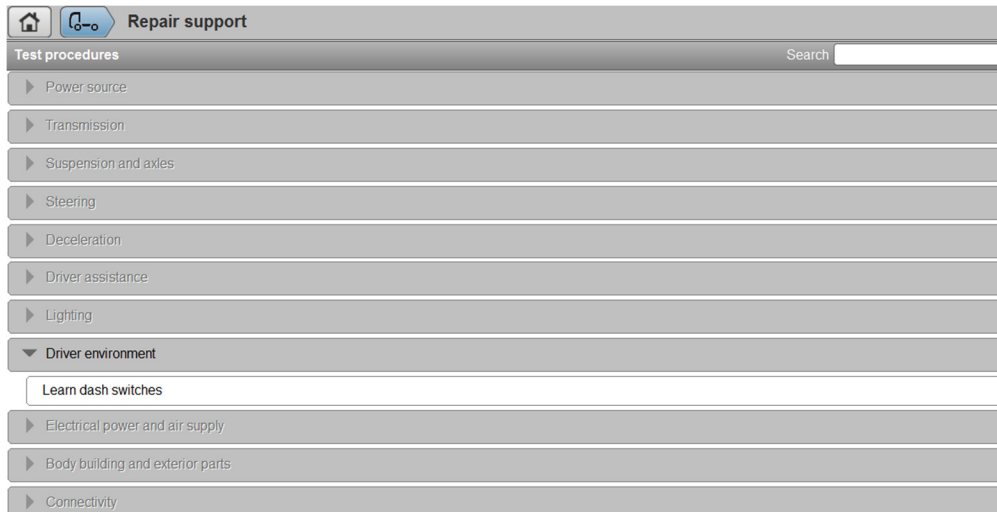

DAVIE Switch Relearn Screen View

SWITCH LOCATION

Switches on the same LIN bus can be reordered in any configuration without the need to run a relearn process with DAVIE tool. Unlike the heavy duty dash, all MUX switches for 2.1M medium duty product are on B-Panel, which operates on LIN bus 2. Therefore, a switch relearn process is not required when moving previously learned switches amongst B-Panel. However, a relearn process is required when adding a new MUX switch that has not previously been learned. Push button switches on A-Panel operate on LIN bus 1 and are not compatible with Lin bus 2 (B-Panel) dash positions.

DASH LAYOUT

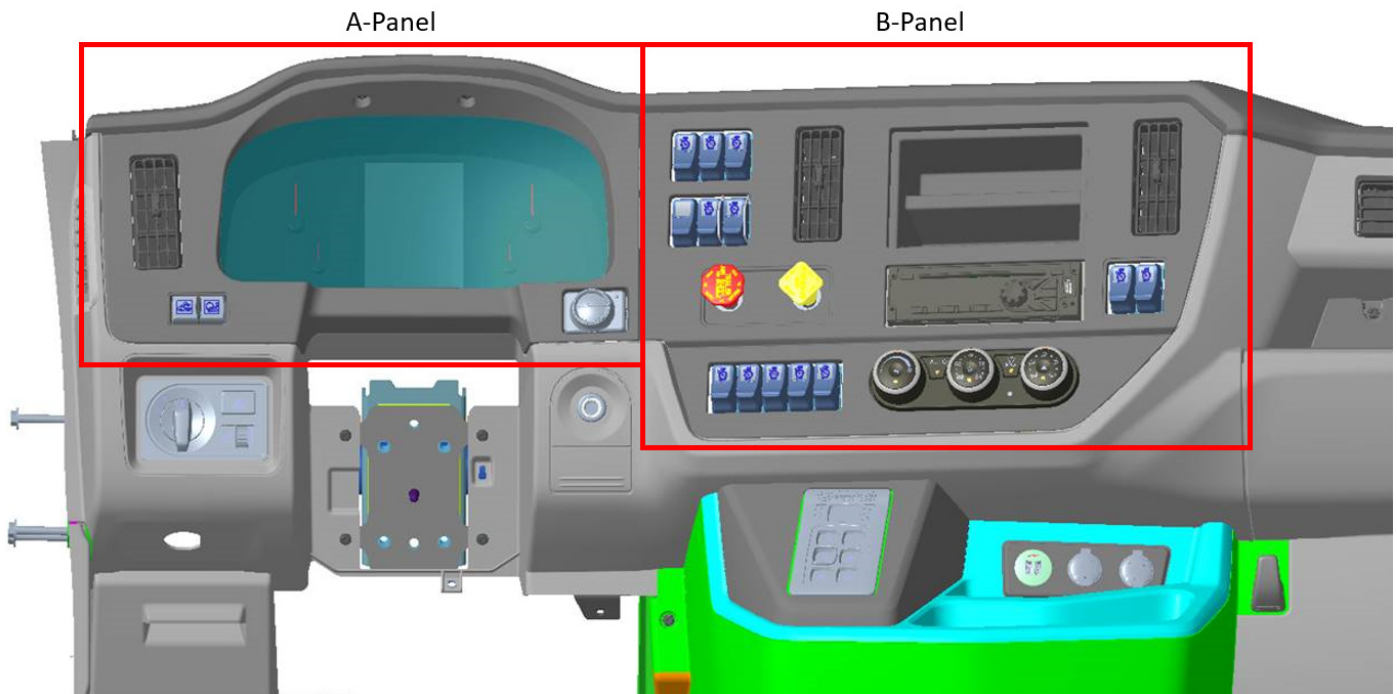

GROUNDING



Grounding any post-OEM component/device/apparatus/etc. to the metal cab structure or frame is not acceptable. Failure to properly ground add-on components can result in vehicle damage and possibly bodily injury.

Ground all post-OEM component/device/apparatus/etc. with combined current draw of less than 30A to the firewall ground buss bar with appropriately sized wire/cable for the load required.

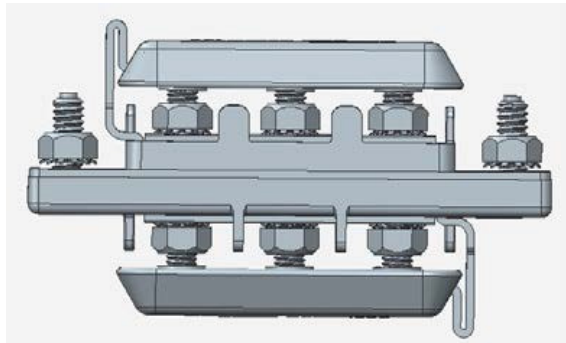

Grounding Buss Bar Design

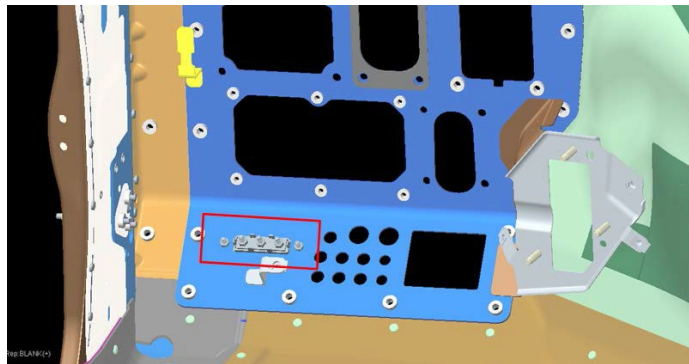

Grounding Point - Cab Interior Behind Driver's Side Kick Panel

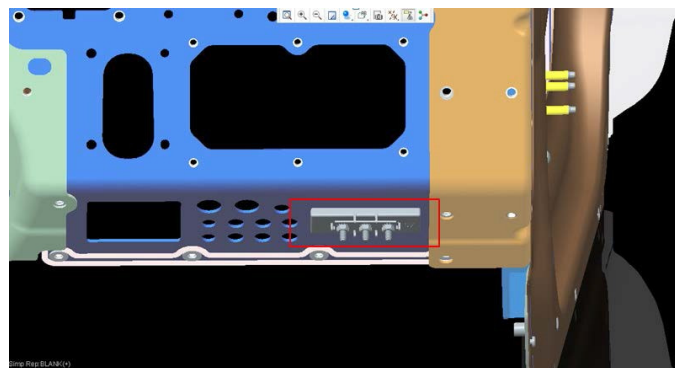

Grounding Point - Cab Exterior LH Side of Firewall

Post OEM components/devices/apparatus/etc. with combined current draw in excess of 30A, ground must be attained from vehicle batteries directly with appropriately sized wire/cable for the load required.

SPARE POWER

Spare power connector P096 is located on lower left side of dash behind key switch or kick panel. The mating harness is available from PACCAR parts with pre-labeled pigtails, P92-8916-000000001. Any spare power requiring more than 20 amps must go directly to the battery box, not this spare circuit.

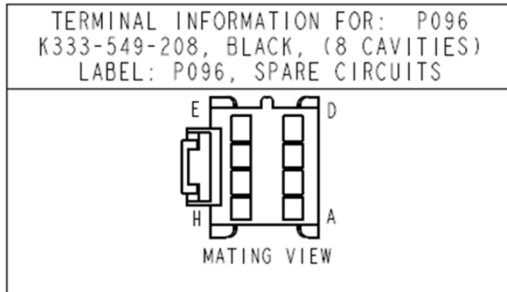

Pin	Spare Circuit No.	Designation	Fuse Max Rating
F	ORN0731-9	Spare Ignition #2	Cab Side - 20A
C	ORN0752-4	Spare Accessory #1	Cab Side - 20A
E	ORN0731-8	Spare Ignition #1	Cab Side - 20A
B	RED0712-5	Spare Battery #1	Cab Side - 20A
G	ORN0791-4	Spare LVD #1	Cab Side - 20A
A	RED0711-1	Spare Battery #2	Engine Side - 20A

SPARE CIRCUIT CONNECTOR

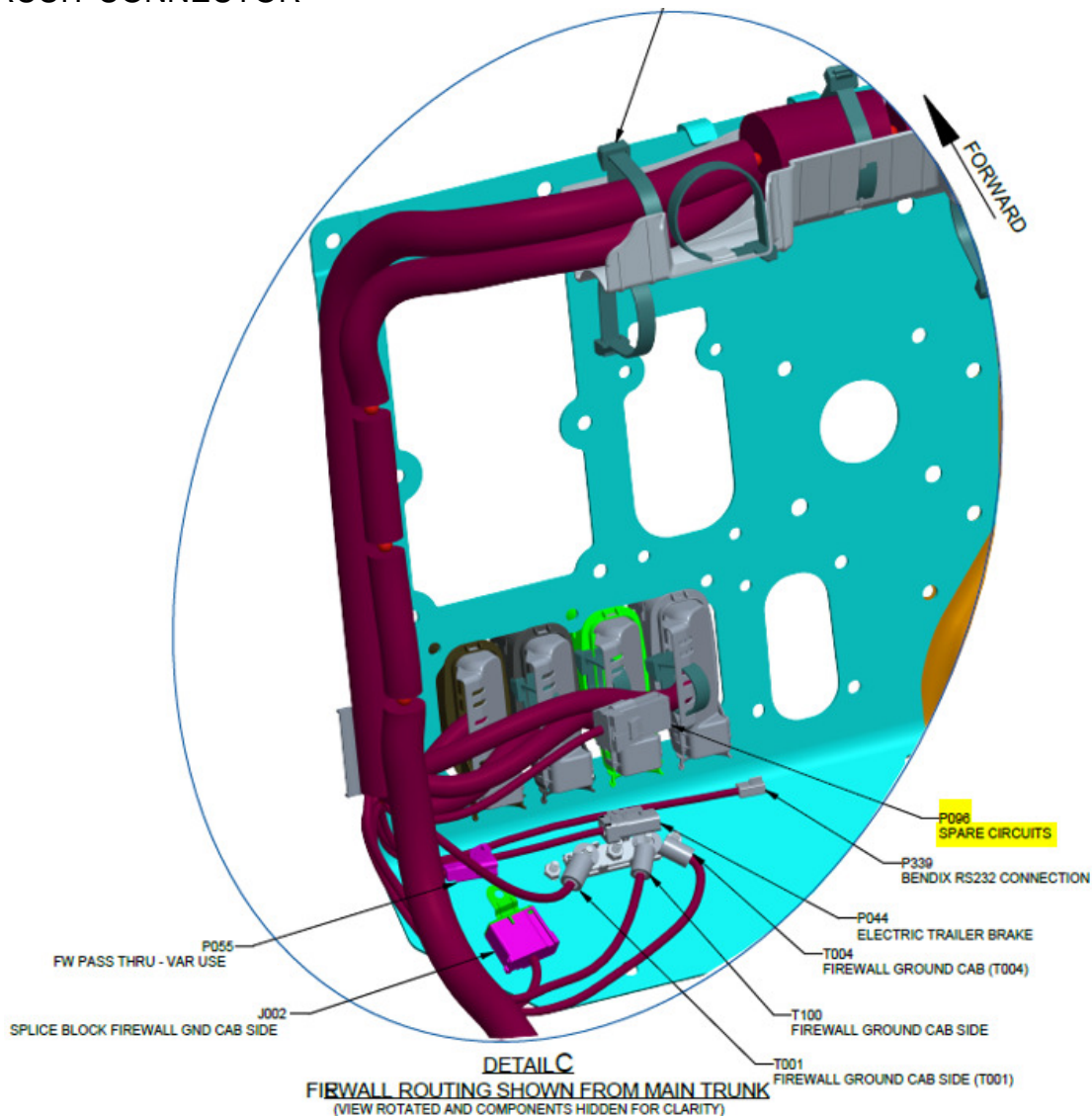

SPARE CIRCUIT LOCATION UNDER DASH P096

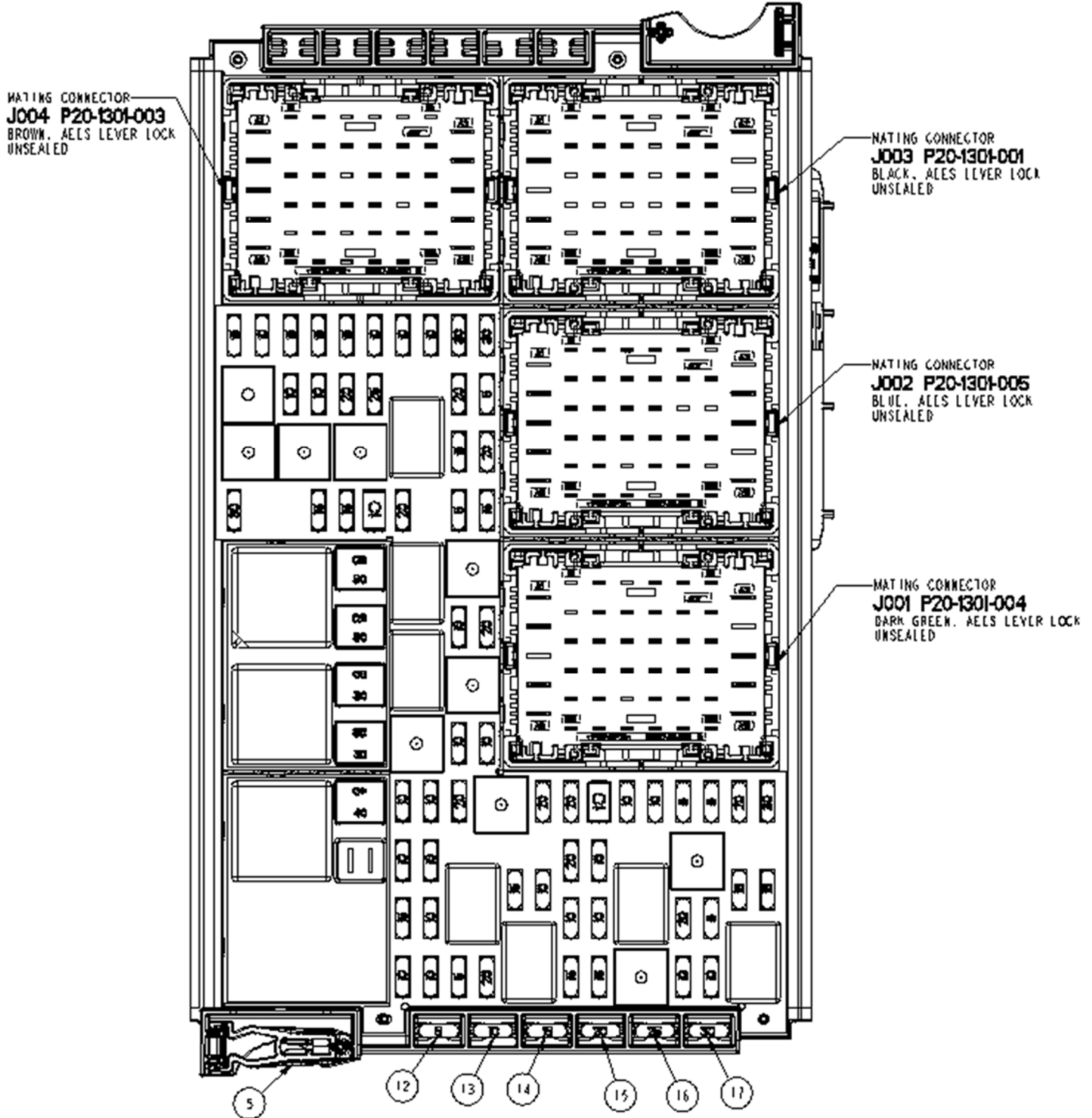

Spare circuit location on Power Distribution Center (Dash-Side, P001)

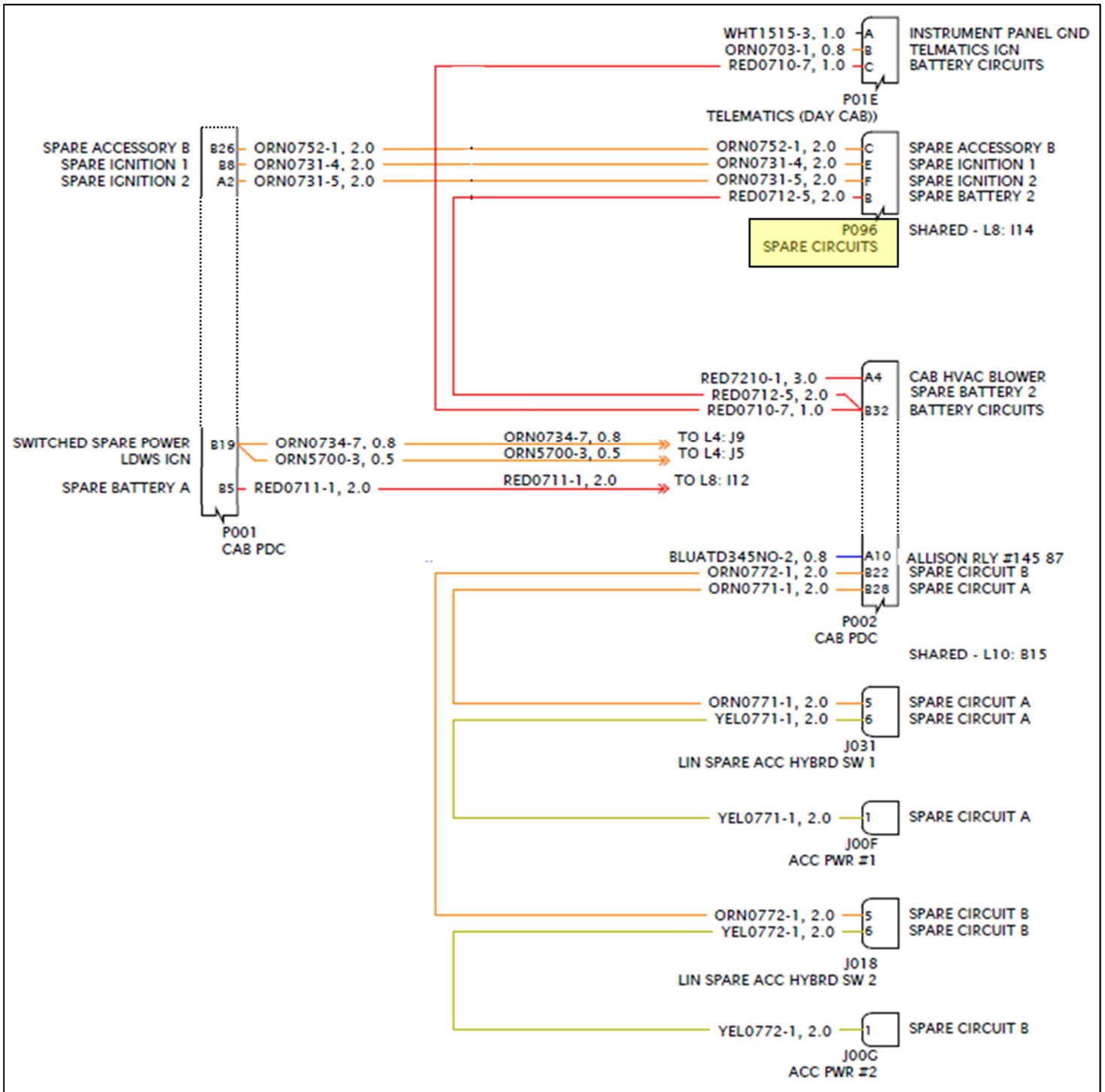

Spare Circuits A & B Diagram (P096)

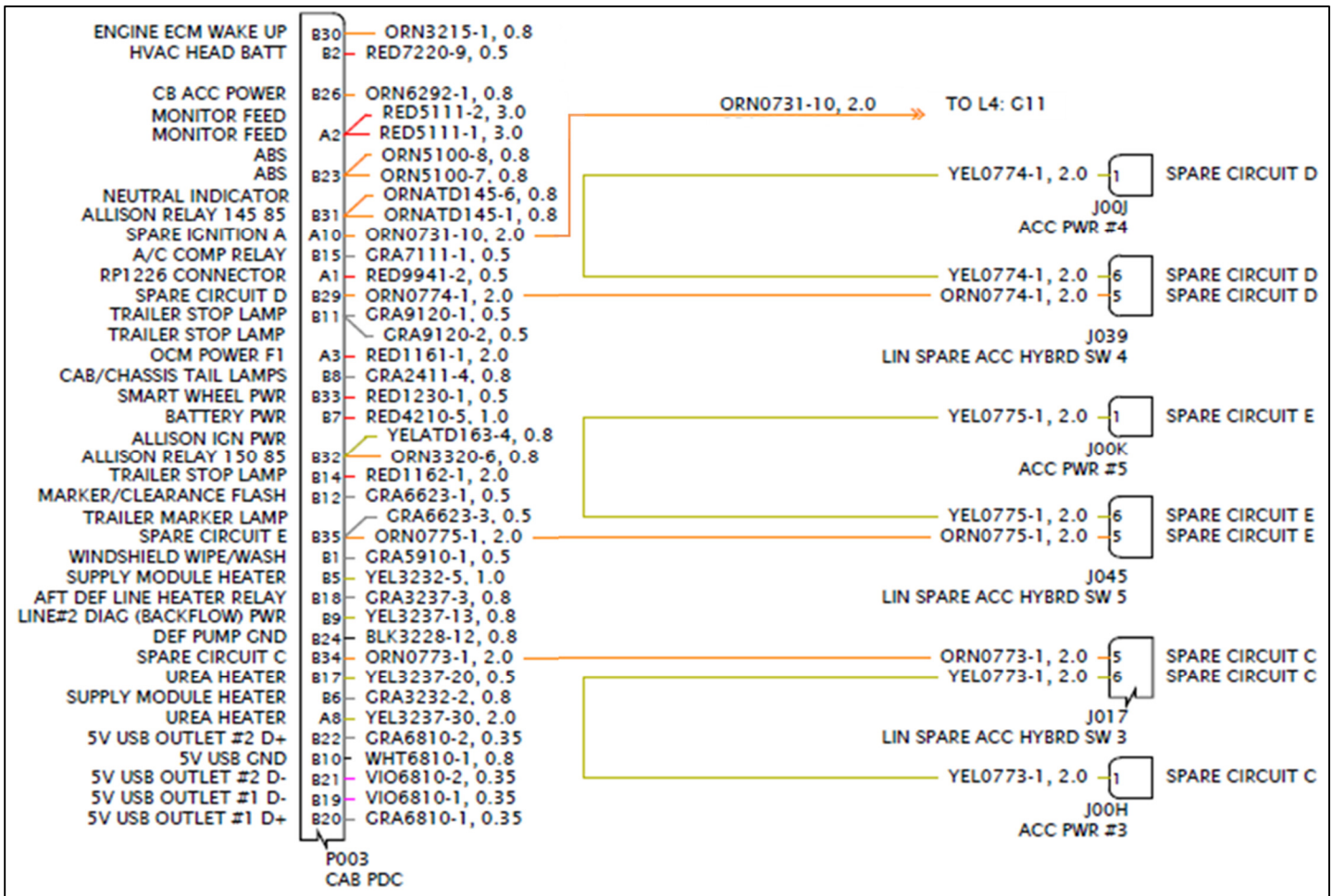

Spare Circuits C, D, & E Diagram

Note: For additional schematic information, please contact your local Peterbilt dealership for assistance.

JUNCTION BOX

The junction box provides access to lighting signals.

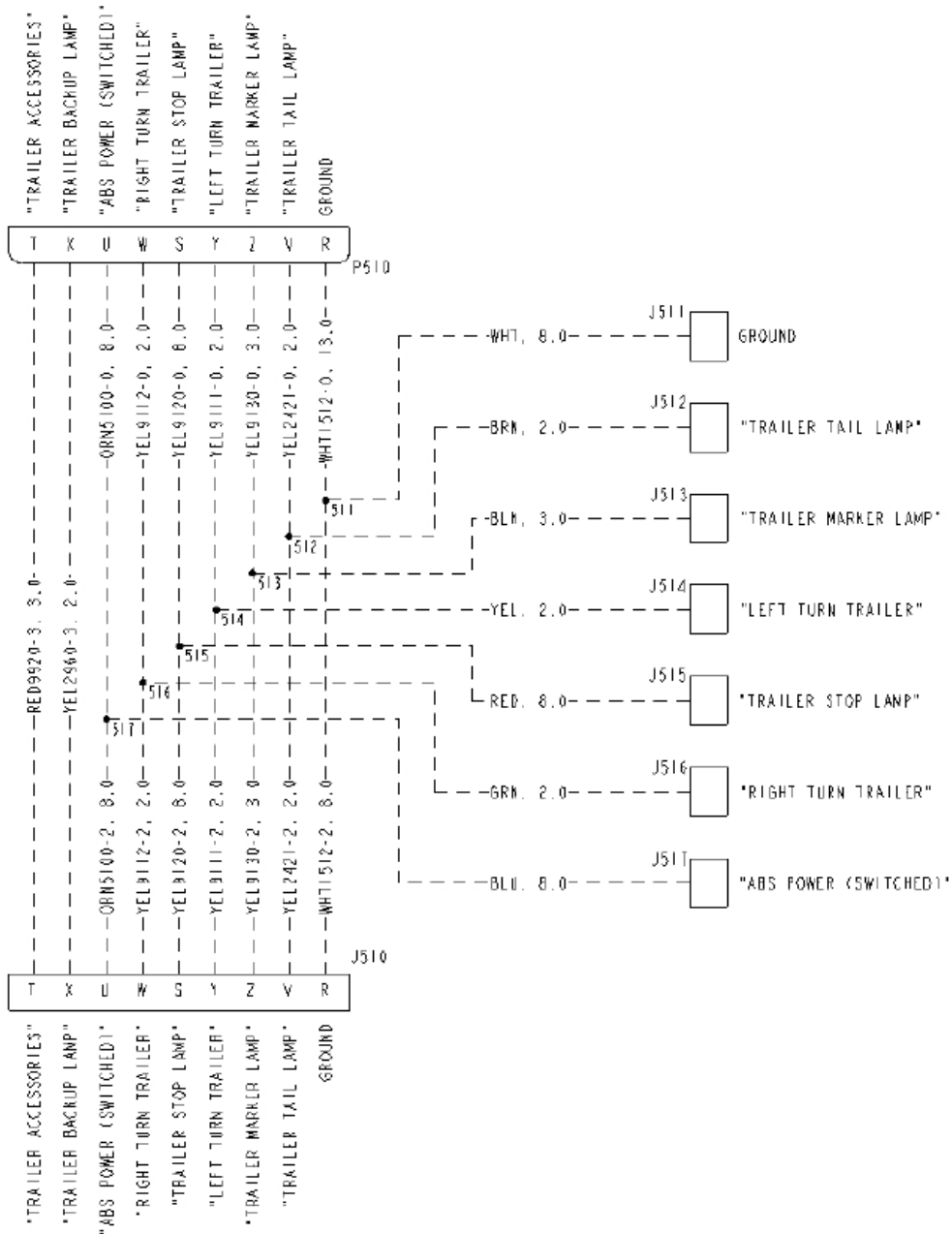
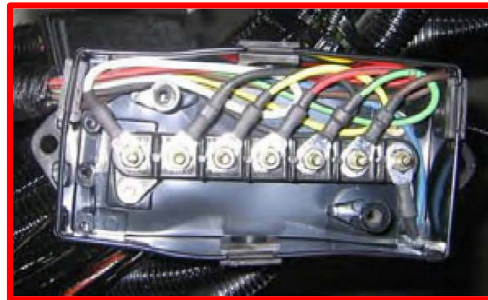

Junction Box BOC or EOF

TRANSMISSION BACKUP SIGNALS

The back-up signal can be accessed from pin D of the 6-way tail light connector located at the end of frame. The tail light connector is a 6-way connector located in the chassis harness at the end of frame. It will either be connected to a tail light, a jumper harness, or tied up in the rail if no tail lights are provided. Note: Back-up signal will also be available in the RP170 connection.

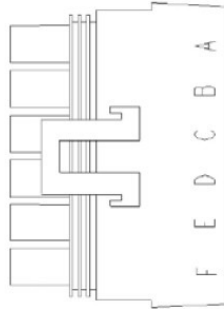

PIN	CIRCUIT DESCRIPTION
A	Park Lamp
B	Left Turn/Stop Lamp
C	Right Turn/Stop Lamp
D	Backup Lamp
E	Aux Chassis
F	Ground

Mating Connector: Packard PN 12020786

SNOW PLOW LIGHTING

When the optional switch and wiring for snowplow lights are ordered, the truck will include a switch on the dash to control the snowplow lights and a body builder connection at the front of the chassis, J168.

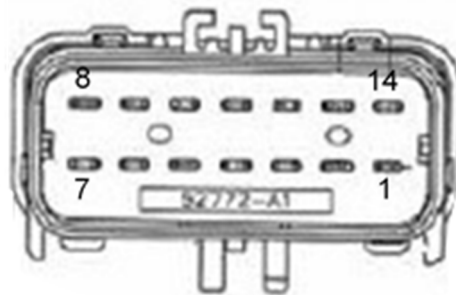

Pin	Description
1	LOW BEAM LH
2	LOW BEAM RH
3	HIGH BEAM LH
4	HIGH BEAM LH
5	TURN INDICATOR LH
6	TURN INDICATOR RH
7	MARKER LAMPS
8	NOT USED
9	SNOWPLOW GROUND
10	SNOWPLOW GROUND
11	TURN INDICATOR, LH DRL
12	TURN INDICATOR, RH DRL

LIFT AXLES (PUSHERS & TAG)

All truck lift axles (pushers and tag), are direct wire Electric-Only. The wiring comes from the Primary Chassis Module or Secondary Chassis Module, and goes direct to the axle mounted solenoid. This is not from the EoA Solenoid Bank. The activation signal comes from either a dash mounted MUX switch, or a hardwired switch that is mounted outside of the cab. There are a total of four lift axle controls available; 3 pushers and 1 tag axle, or 4 pushers and no tag. These are controlled with separate switches by default, but it is possible to have a single switch control all axles if they are the same type. The customer can order the following configurations; steerable, non-steerable, with auto-reverse, and with park brake interlock. A lift axle comes with a control switch (single or separate), a gauge, and a regulator valve.

LIFT AXLE DIAGRAM

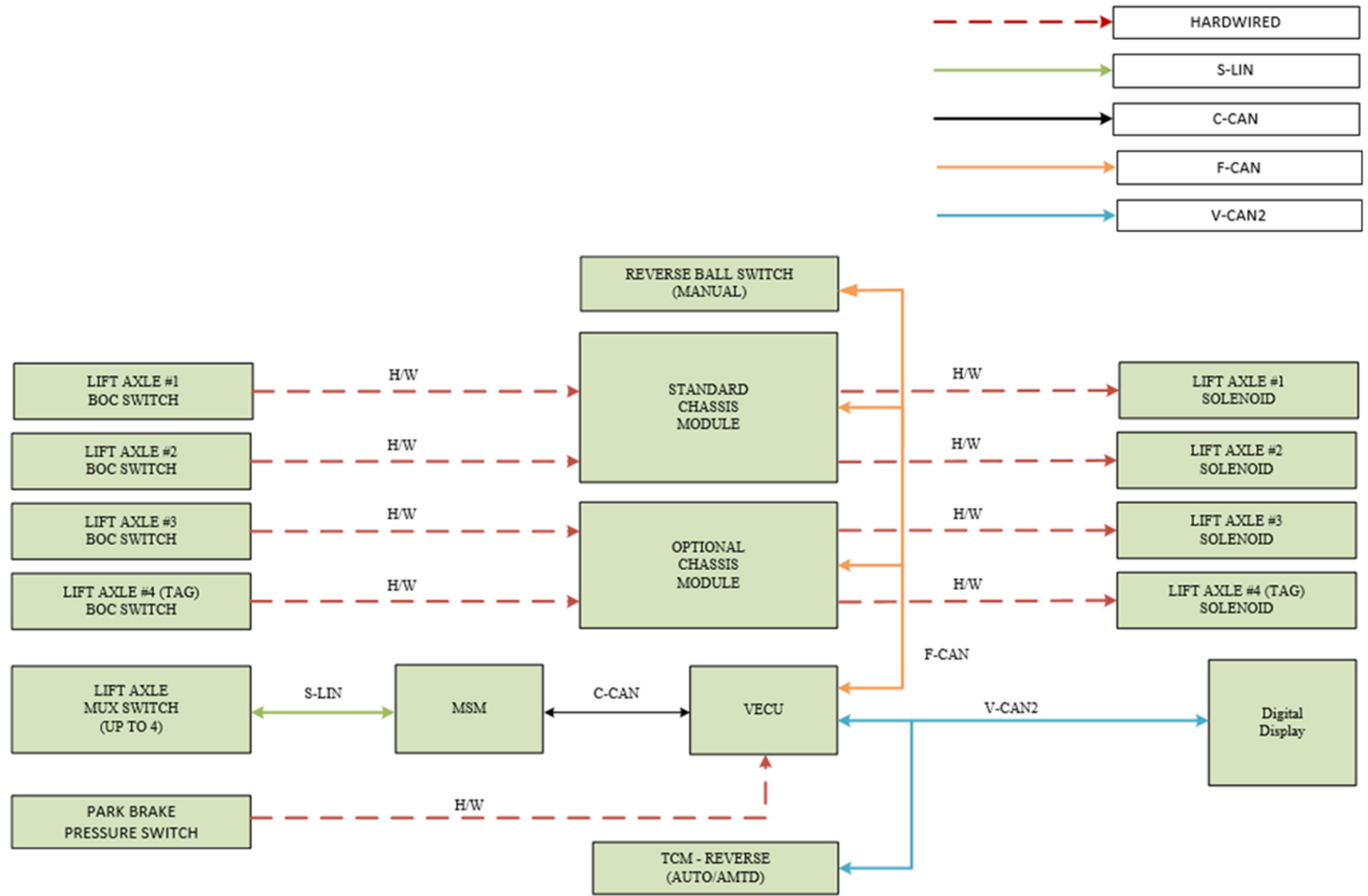

TRUCK LIFT AXLE LOGIC

Lift Axle Type	Raise Condition Logic	Lower Condition Logic
Steerable Lift Axle w/o Auto-Reverse	- Lift Switch is Inactive OR - Park Brake Active OR - Trans in Reverse	- Lift Switch is Active AND - Park Brake Inactive AND - Trans Not in Reverse
Steerable Lift Axle with Auto-Reverse OR Non-Steerable Lift Axle w/o Park Brake	- Lift Switch is Inactive OR - Park Brake Active	- Lift Switch is Active AND - Park Brake Inactive
Non-Steerable Lift Axle with Park Brake	- Lift Switch is Inactive AND - Park Brake Inactive	- Lift Switch is Active OR - Park Brake Active

TRAILER LIFT AXLE

Trailer lift axles can be either EoA or Electric-Only type. There are a total of two available EoA trailer lift axle controls using latching solenoids. If one axle is ordered, the customer will receive a switch labeled “Trailer Lift Axle”. If two axles are ordered, the customer can have a single switch that controls both axles or two switches. If two switches are present, they are labeled “Forward Trailer Lift Axle” and “Rear Trailer Lift Axle”.

DIGITAL DISPLAY

The standard display comes with a set of gauges. A limited number of additional gauges can be configured on the 7” digital display after the initial truck build using Paccar Vehicle Pro (PVP). Please contact your local Peterbilt dealership for assistance.



Gauges on the 7” Digital Display

TELLTALE ICONS

Custom Telltales will no longer be available with a physical card inserted into the dash cluster. Instead, the body builder telltales will populate on the digital portion of the display from a limited list and can be reconfigured using PVP at your local Peterbilt dealership. The location of the telltale will be dependent on the configuration of the vehicle and what other telltales are present on the digital display.



Body Builder Telltale Positions

The Digital Display is capable of receiving up to 5 hardwire inputs to trigger the body builder (editable) telltales on the 2.1 Medium Duty product with one editable telltale associated with an analog signal in the IP harness behind the cluster.

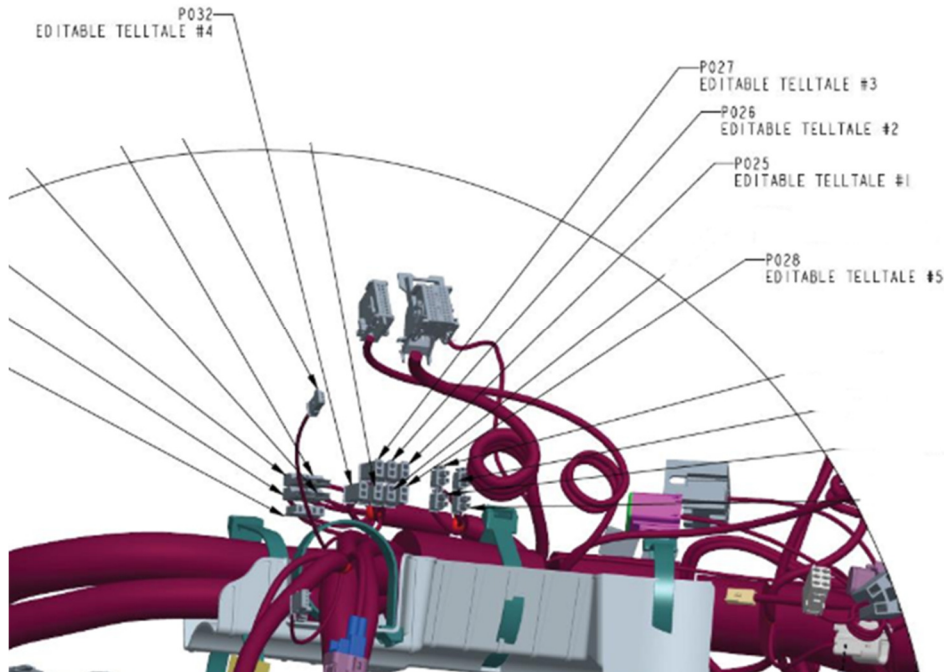

Body Builder Telltale Connections

SECTION 8 POWER TAKE-OFF (PTO)

INTRODUCTION

A Power Take-Off (PTO) provides a way to divert some or all of the trucks engine power to another component. There are a wide variety of PTO options available.

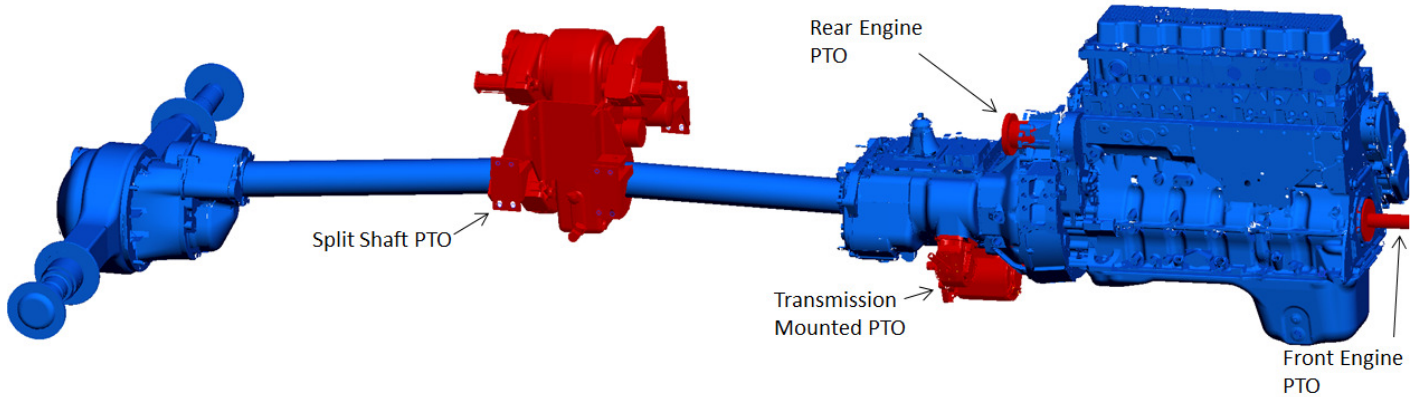

PTO ACRONYM LIBRARY

Acronym	Definition	Acronym	Definition
ABS	Anti-Lock Braking System	PCC	Predictive Cruise Control
CAN	Controller Area Network	PDC	Power Distribution Center
CC	Cruise Control	PGN	Parameter Group Number
DEF	Diesel Exhaust Fluid	PMC	PTO Mode Control
DTC	Diagnostics Trouble Code	PSC	PTO Speed Control
ECM	Engine Control Module	PTO	Power Take Off
ECU	Electrical Control Unit	PVP	PACCAR Vehicle Pro
EIST	Engine Idle Shutdown Timer	RP1226	TMS Messaging Standard
EOA	Electric Over Air	SCM	Standard Control Module
EOH	Electric Over Hydraulic	SCR	Selective Catalyst Reduction
FIC	Fast Idle Control	SPN	Suspect Parameter Number
J-1939	SAE CAN Communication Standard	TCM	Transmission Control Module
LIN	Local Interconnect Network	TSC1	Torque Speed Control (request)
MSB	Master Solenoid Bank	VECU	Vehicle Electrical Control Unit
MSM	Master Switch Module		
MUX	Multiplex		
OBD	On Board Diagnostics		
OCM	Optional Control Module		
OEM	Original Equipment Manufacture		

TRANSMISSION MOUNTED PTO

MANUAL TRANSMISSIONS

This is the most common type of PTO that is used. On a manual transmission, there are two locations for PTOs. On medium duty, transmissions there are 6 bolt PTO locations on the right and left. On heavy duty manual transmissions there is a 6 bolt PTO on the right and an 8 bolt PTO on the bottom left. There are also some options for a thru shaft or extended countershaft PTO. On a thru shaft PTO, the counter shaft extends out through the back of the transmission, which can be used to power a PTO. When using a thru shaft PTO the vehicle must be spec'd with the correct option, as not all transmissions will be set up for use with thru shaft PTOs. For more information go to www.roadranger.com and enter "PTO Installation Guide" in the search bar in the upper right corner.



MD Manual Transmission



MD Automated (10-Speed)

AUTOMATIC TRANSMISSIONS - ALLISON

On Allison transmissions there are two locations for PTOs. The Allison 4000 series has PTO locations at 1 and 8 o'clock viewed from the back of the transmission. The 4000HS transmissions do not have any PTO locations. The 3000 series Allison transmissions have PTO locations at 4 and 8 o'clock. For more information on using PTOs with an Allison transmission go to www.allisontransmission.com and refer to the "Rugged Duty Series Brochure" and "PTO Request Flyer" which is available in a 1000/2000 version and a 3000/4000 version.

Some PTO configurations will have clearance issues with other components on the truck. With manual transmissions, a 6-bolt PTO on the right will typically clear most components when the DPF and SCR are under the cab. This is also true when 30 and 45 degree adapters are used. On Allison 4000 series transmissions, most PTOs will fit in the 1 o'clock position without interfering with the cab. If a wet kit is used here, the dipstick housing will most likely need to be modified as it runs over the top of the transmission to the driver side of the vehicle. The PTO in the 8 o'clock position is typically ok. There are some scenarios where the PTO will be very close to or could interfere with the rear spring shackle on the front suspension. This problem can occur on vehicles with a set-back front axle and the problem is amplified on the short hood models.

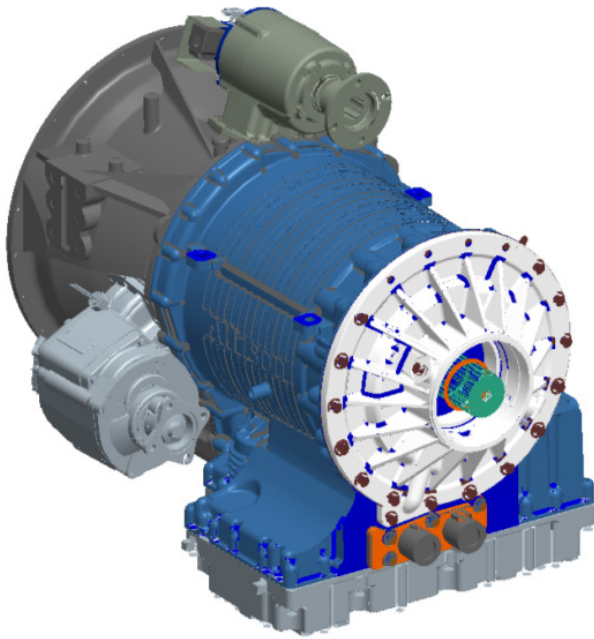

Allison 4000 Series

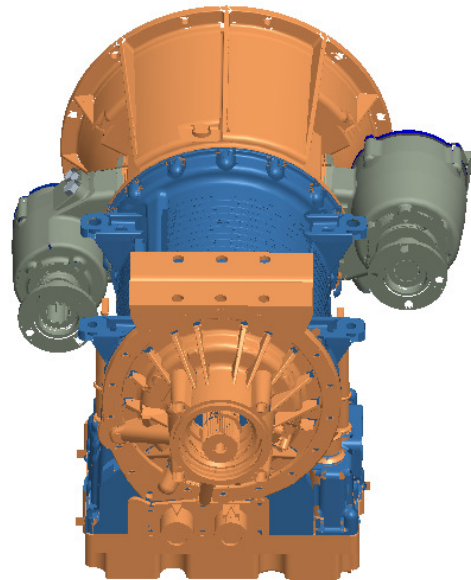

Allison 3000 Series

AUTOMATIC TRANSMISSIONS – PACCAR 8-SPEED

There are two locations for PTOs on the PACCAR 8-speed transmission: 9 o'clock and 3 o'clock from the back of the transmission. The PACCAR 8-speed automatic transmission is relatively wide at the PTO mounting locations. For this reason, it is important to be aware of potential PTO packaging issues. Frame rails and frame mounted hose bundles can present a challenge, depending on the specific configuration. If the PTO is using an elongated driveshaft it is advised to be aware of the location of the back of cab crossmember in relation to the driveshaft. PTOs mounted in the 9 o'clock position on the PACCAR 8-speed may need a spacer to clear the transmission shift actuator.

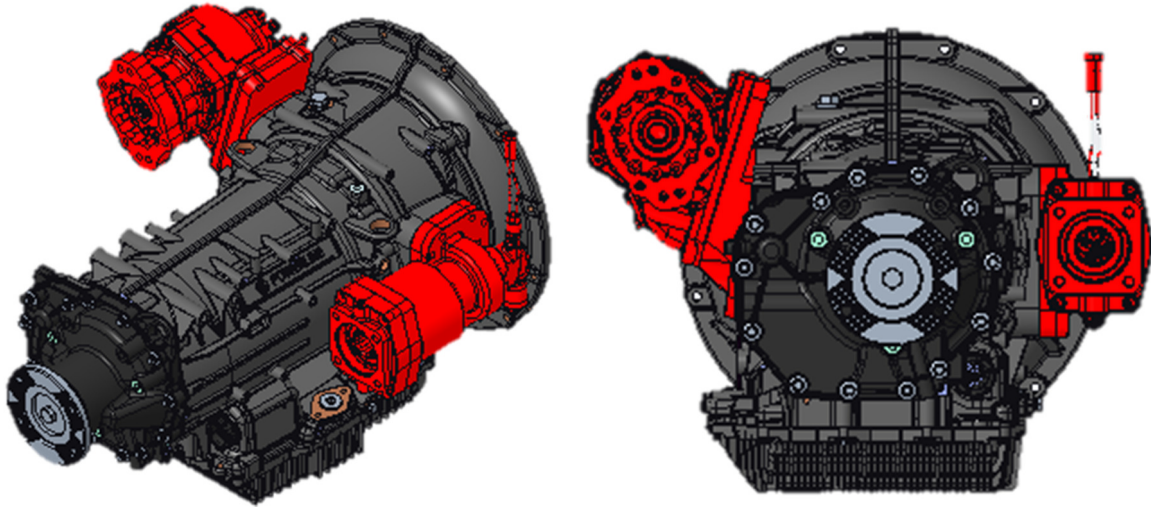

PACCAR 8-Speed Automatic Transmission

FRONT ENGINE PTO

Front engine PTO (FEPTO) is commonly used in mixer, snowplow, and crane applications. When a FEPTO is spec'd on a truck, the cooling module moves up to allow for a shaft to be bolted to the front of the crankshaft and extend out to the front of the truck. The vehicle can be spec'd with a 1350 flange adapter to simplify installing the FEPTO shaft. The frame rails will be extended out to mount a hydraulic pump, snowplow, or outriggers. The frame extension is 24" long and a full rail profile, see Figure 7-12.

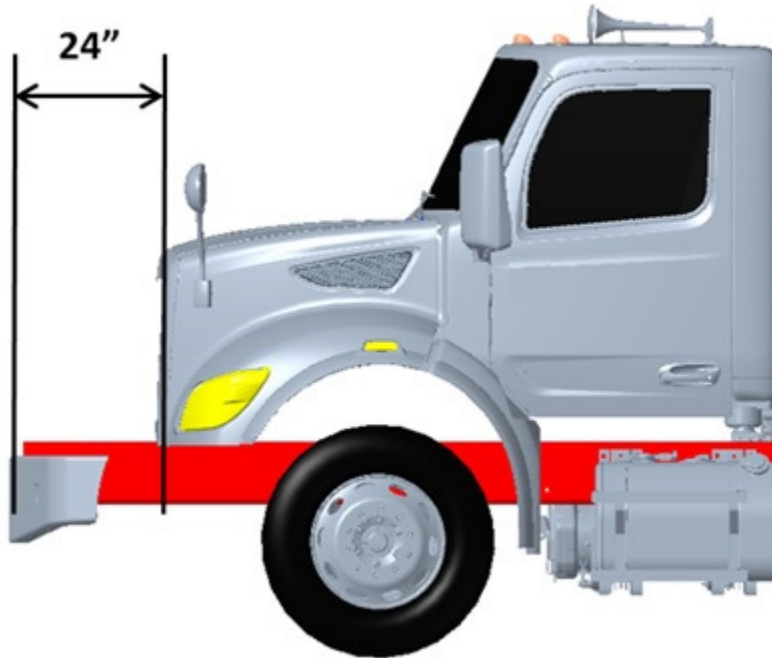

FIGURE 7-12. FEPTO 24" Full Profile Frame Extension

PTO MOUNTING CLEARANCE

This application guide indicates if a PTO has sufficient clearance to truck components in various mounting configurations. The truck components investigated in this guide include frame rails, Set Back Front Axle (SBFA) rear shackle, SBFA Front Air Suspension (FAS) rear shackle, over-bell frame brace, coolant return manifold, transmission clutch actuator, and exhaust system components.

Usage Notes:

1. This application guide is only applicable to 2.1M trucks.
2. Only the specified PTO configurations have been analyzed.
3. Horizontal aftertreatment limits access behind PTO's for shaft drives and other PTO attachments.
4. Eaton FR transmissions require the use of a 30° adapter when installing Chelsea or Muncie transmission PTOs in the right hand position.
5. Eaton RT & UltraShift Plus transmissions require the use of a 45° adapter when installing Chelsea transmission PTOs in the right hand position.
6. Eaton RT & UltraShift Plus transmissions require the use of a 55° adapter when installing Muncie transmission PTOs in the right hand position.
7. Eaton transmissions require the use of a 6 to 8 Bolt adapter when installing a 6 bolt PTO in the bottom position.

PTO MOUNTING CLEARANCE CHARTS – ALLISON TRANSMISSIONS

**PTO's for 1000/2000
Allison Transmissions
-7L Only-**

			4 o'clock & 8 o'clock						
Brand	PTO		SH		MH		Voc		
	Series	Type	4	8	4	8	4	8	
6-Bolt	Chelsea	272	E3	x	ok	x	ok	ok	ok
			E5	x	x	ok	x	ok	ok
		442	V3	x		ok		ok	
			V5		ok		ok		ok
	Muncie	CS6	H1	x		x		ok	
			H3		x		x		ok
		FA6B	H3		x		ok		ok
		TG6	H1	x		ok		ok	
			H3		ok		ok		ok

Clocking Position on Transmssion

x Will not package in truck

ok Will package in truck

Requires "RH PTO" exhaust

			3000 - 4 o'clock & 8 o'clock Positions																		
			7L						9L						9L REPTO						
Brand	PTO		SH		MH		Voc		SH		MH		Voc		MH		Voc				
	Series	Type	4	8	4	8	4	8	4	8	4	8	4	8	4	8	4	8			
10-Bolt	Chelsea	267	M3	x		ok		ok		x		ok		ok		ok		ok			
			M5		ok		ok		ok		ok		ok		ok		ok		ok		
		280	E3	x		ok		ok		x		ok		ok		ok		ok		ok	
			E5		ok		ok		ok		ok		ok		ok		ok		ok		ok
		287	M3	x		ok		ok		x		ok		ok		ok		ok		ok	
			M5		ok		ok		ok		ok		ok		ok		ok		ok		ok
		870	E3	x		x		ok		x		x		ok		ok		ok		ok	
			E5		x		x		ok		x		x		ok		ok		ok		ok
		877	M3	x		x		ok		x		x		ok		ok		ok		ok	
			M5		x		x		ok		x		x		ok		ok		ok		ok
	890	R-B5	x		x		ok		x		x		ok		ok		ok		ok		
		L-B5		x		x		ok		x		x		ok		ok		ok		ok	
		T-B5																			
		E-B5																			
		U-B5																			
		H-B5																			
	897	R-M5	x		x		ok		x		x		ok		ok		ok		ok		
		L-M5		x		x		ok		x		x		ok		ok		ok		ok	
		T-M5																			
		E-M5																			
U-M5																					
H-M5																					
Muncie	CD05	M3		ok		ok		ok		ok		ok		ok		ok		ok			
	CD10	M1	x		ok		ok		x		ok		ok		ok		ok		ok		
		M3		ok		ok		ok		x		x		ok		ok		ok		ok	
	CD40	M1	x		x		ok		x		x		ok		x		ok		ok		
		M3		x		x		ok		x		x		ok		x		ok		ok	
	CS10	H1	x		x		ok		x		x		ok		x		x		x		
		H3		x		x		ok		x		x		ok		x		x		x	
	CS24	H1																			
		H3																			
	CS41	H1	x		x		ok		x		x		ok		x		ok		ok		
		H3		x		x		ok		x		x		ok		x		ok		ok	
	HS24	H1	x		ok		ok		x		ok		ok		ok		ok		ok		
		H3		ok		ok		ok		ok		ok		ok		ok		ok		ok	
	A20	HX1	x		ok		ok		x		ok		ok		ok		ok		ok		
HX3			ok		ok		ok		ok		ok		ok		ok		ok		ok		
HX5																					

x Will not package in truck
ok Will package in truck
4 Requires "RH PTO" exhaust

		3000 - 1 o'clock & 8 o'clock Positions																		
		7L						9L						9L REPTO						
Brand	Series	PTO Type	SH		MH		Voc		SH		MH		Voc		MH		Voc			
			1	8	1	8	1	8	1	8	1	8	1	8	1	8	1	8		
10-Bolt	Chelsea	267	M3	x		x		x		x		ok		ok		x		x		
			M5		x		x		ok		x		x		ok		ok		ok	
		280	E3	x		x		x		x		ok		x		x		x		
			E5		x		x		ok		x		x		ok		ok		ok	
		287	M3	x		x		x		x		ok		x		x		x		x
			M5		x		x		ok		x		x		ok		ok		ok	
		870	E3	x		x		x		x		ok		x		x		x		x
			E5		x		x		ok		x		x		ok		x		ok	
		877	M3	x		x		x		x		ok		x		x		x		x
			M5		x		x		ok		x		x		ok		x		ok	
	890	R-B5																		
		L-B5																		
		T-B5	x		x		x		x		x		ok		x		x			
		E-B5		x		x		ok		x		x		ok		x		ok		
		U-B5																		
		H-B5																		
	897	R-M5																		
		L-M5																		
		T-M5	x		x		x		x		x		ok		x		x			
		E-M5		x		x		ok		x		x		ok		x		ok		
U-M5																				
H-M5																				
Muncie	CD05	M3		ok		ok		ok		ok		ok		ok		ok		ok		
	CD10	M1	x		x		x		ok		ok		x		x		x			
		M3		x		x		ok		x		x		ok		x		ok		
	CD40	M1	x		x		x		ok		ok		x		x		x			
		M3		x		x		ok		x		x		x		x		ok		
	CS10	H1	x		x		x		ok		ok		x		x		x			
		H3		x		x		x		x		x		x		x		x		
	CS24	H1																		
		H3																		
	CS41	H1	x		x		x		ok		ok		x		x		x			
		H3		x		x		ok		x		x		x		x		ok		
	HS24	H1																		
		H3	x	x	x	x	ok	ok	ok	x	ok	x	ok	ok	x	ok	x	ok		
	A20	HX1																		
HX3			x		x		ok		x		x		ok		ok		ok			
HX5		x		x		x		ok		ok		x		x		x				

x Will not package in truck
ok Will package in truck
□ Requires "RH PTO" exhaust

Brand		PTO		4000							
				9L				9L REPTO			
				MH		Voc		MH		Voc	
Series	Type	1	8	1	8	1	8	1	8		
10-Bolt	Chelsea	267	M3	ok		ok		x		x	
			M5		ok		ok		ok		ok
		280	E3								
			E5	ok	x	ok	ok	x	ok	x	ok
		287	M3								
			M5	ok	x	ok	ok	x	ok	x	ok
		870	E3	ok		ok		x		x	
			E5		x		x		ok		ok
		877	M3	ok		ok		x		x	
			M5		x		x		ok		ok
		890	R-B5								
			L-B5								
			T-B5								
			E-B5								
	U-B5		x		x		x		x		
	H-B5			x		x		ok		ok	
	897	R-M5									
		L-M5									
		T-M5									
		E-M5									
		U-M5	x		x		x		x		
		H-M5		x		x		ok		ok	
	Muncie	CD05	M3								
		CD10	M1	ok		ok		x		x	
			M3		x		x		ok		ok
		CD40	M1	ok		ok		x		x	
			M3		x		x		x		x
		CS10	H1	ok		ok		x		x	
H3				ok		x		x		x	
CS24		H1									
		H3									
CS41		H1	ok		ok		x		x		
		H3		x		x		x		ok	
HS24		H1									
		H3	ok	ok	ok	ok	x	ok	x	ok	
A20		HX1									
	HX3		x		ok		ok		ok		
	HX5	ok		ok		x		x			

x Will not package in truck
ok Will package in truck
■ Requires "RH PTO" exhaust

PTO MOUNTING CLEARANCE CHARTS – PACCAR 8-SPEED TRANSMISSION

			ZF/PACCAR 8 Speed - 3 and 9 o'clock Positions											
			Engine											
			PX-7						PX-9					
Brand	PTO Series	Pump	SH		MH		Voc		SH		MH		Voc	
			3	9	3	9	3	9	3	9	3	9	3	9
Chelsea	Z35	F1	x	ok	x	ok		ok	x	ok	x	ok		ok
		SG102	x	x	x	x		x	x	x	x	x		x
		PGP020	x	x	x	x		x	x	x	x	x		x
		PGP350	x	x	x	x		x	x	x	x	x		x
		Driveshaft	x	x	ok	x		x	ok	x	ok	x		x
	272 Slim Line	F1	x	ok	x	ok			x	ok	x	ok		
		SG102	x	ok	x	ok			x	ok	x	ok		
		PGP020	x	ok	x	ok			x	ok	x	ok		
		PGP350	x	ok	x	ok			x	ok	x	ok		
		Driveshaft	x	x	x	x			x	x	x	x		
Muncie	N/A	N/A												

PTO MOUNTING CLEARANCE CHARTS – EATON TRANSMISSIONS

Single PTO's for Eaton Transmissions
LH, RH or Bottom Mounted

PTO	SAE #2	SAE #1														
		FS/FSO		FR/FRO		RT/RTO/RTLO		FR/FRO		RT/RTO/RTLO		Ultrashift + Adv AMT		Endurant PACCAR AMT		
		Left	Right	Bottom	Right	Bottom	Right	Bottom	Right	Bottom	Right	Bottom	Right	Bottom		
Chelsea	6-Bolt	272	V3	S		S		S		S		S		S		
			V5	S												
		340	V5	S	S		S		S		S		S		S	
			V3		S		S		S		S		S		S	
		442	V3		S		S		S		S		S		S	
	V5		S													
	660	V3				S		S		S		S		S		
	8-Bolt	282	V3			S		S		S		S		S		
		348	V5			S		S		S		S		S		
		489	V5			S		S		S		S		S		S
		680	V3			S		S		S		S		S		
		823	V3			S		S		S		S		S		
		880	V3			O		O		O		O		S		S
		885	V3			O		O		O		O		S		
Muncie	6-Bolt	CS6	P1		S		X		X		S		S		S	
			P3	S												
		RL6	A3	S	S		X		S		S		S		S	
		SH6	P1		S		X		X		S		S		S	
			P3	S												
		TG6	P1		S		X		X		S		S		S	
	P3		S													
	8-Bolt	828	P1			S		S		S		S		S		S
		CS8	P1			S		S		S		S		S		
		RL8	A3			S		S		S		S		S		
		SH8	P1			S		S		S		S		S		S
		TG8	P1			S		S		S		S		S		S

s = Will package for this configuration w/
 Standard Hydraulic Clutch Actuator

o = Will package for this configuration w/
 Optional Hydraulic Clutch Actuator

ok = Will package for this configuration

x = Will not package for this configuration

Dual PTO's for Eaton Transmissions RH Mounted with LH or Bottom Mounted

		RH Side Mounted																								
		Chelsea																								
		SAE #2								SAE #1																
		FS/FSO			FR/FRO				RT/RTO/RTLO				FR/FRO				RT/RTO/RTLO Adv Man				Ultrashift+ Adv AMT					
PTO		Z72-V3	340-V5	442-V3	Z72-V3	340-V5	442-V3	660-V3	Z72-V3	340-V5	442-V3	660-V3	Z72-V3	340-V5	442-V3	660-V3	Z72-V3	340-V5	442-V3	660-V3	Z72-V3	340-V5	442-V3	660-V3		
Bottom or LH Side Mounted	6-Bolt	272	V5	s	s	s																				
		340	V5	s	s	s																				
		442	V5	s	s	s																				
	8-Bolt	282	V3				s	s	s	s	s	s	s	s	s	s	s	s	s	s	s	s	s	s	s	
		348	V5				s	s	s	s	s	s	s	s	s	s	s	s	s	s	s	s	s	s	s	
		489	V5				s	s	s	s	s	s	s	s	s	s	s	s	s	s	s	s	s	s	s	
		680	V3				s	s	s	s	s	s	s	s	s	s	s	s	s	s	s	s	s	s	s	
		823	V3				s	s	s	s	s	s	s	s	s	s	s	s	s	s	s	s	s	s	s	
		880	V3				x	x	x	x	x	x	x	x	o	o	x	x	o	o	o	o	o	o	o	o
		885	V3				x	x	x	x	x	x	x	x	o	o	x	x	o	o	o	o	o	o	o	o

		RH Side Mounted																								
		Muncie																								
		SAE #2								SAE #1																
		FS/FSO				FR/FRO				RT/RTO/RTLO				FR/FRO				RT/RTO/RTLO Adv Man				Ultrashift+ Adv AMT				
PTO		CS6-P1	RL6-A3	SH6-P1	TG6-P1	CS6-P1	RL6-A3	SH6-P1	TG6-P1	CS6-P1	RL6-A3	SH6-P1	TG6-P1	CS6-P1	RL6-A3	SH6-P1	TG6-P1	CS6-P1	RL6-A3	SH6-P1	TG6-P1	CS6-P1	RL6-A3	SH6-P1	TG6-P1	
Bottom or LH Side Mounted	6-Bolt	CS6	P3	s	s	s	s																			
		RL6	A3	s	s	s	s																			
		SH6	P3	s	s	s	s																			
		TG6	P3	s	s	s	s																			
	8-Bolt	828	P1					x	x	x	x	x	s	x	x	s	s	s	s	s	s	s	s	s	s	
		CS8	P1					x	x	x	x	x	s	x	x	s	s	s	s	s	s	s	s	s	s	
		RL8	A3					x	x	x	x	x	s	x	x	s	s	s	s	s	s	s	s	s	s	
		SH8	P1					x	x	x	x	x	s	x	x	s	s	s	s	s	s	s	s	s	s	
		TG8	P1					x	x	x	x	x	s	x	x	s	s	s	s	s	s	s	s	s	s	
								x	x	x	x	x	s	x	x	s	s	s	s	s	s	s	s	s	s	s

s = Will package for this configuration w/ Standard Hydraulic Clutch Actuator
o = Will package for this configuration w/ Optional Hydraulic Clutch Actuator
ok = Will package for this configuration
x = Will not package for this configuration

HYDRAULIC CLUTCH ACTUATOR CONFIGURATIONS

(Only used with 2.1M models with Eaton transmissions)

Eaton FR, RT and Advantage manual transmissions with SAE #1 or SAE #2 Clutch Housings

Eaton FS manual transmissions with SAE #2 Clutch Housings

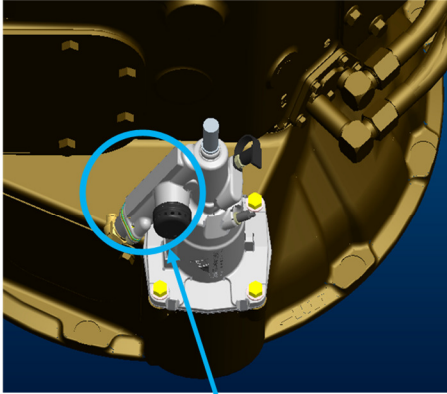

Standard Configuration

Air assist connection faces driver's side

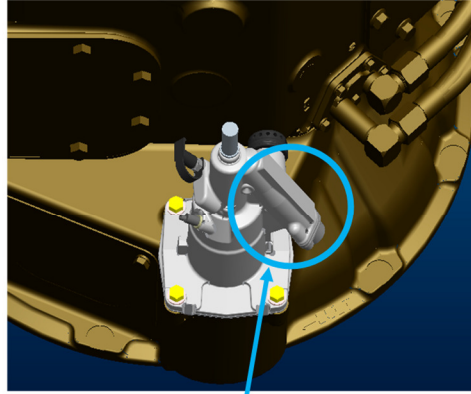

Optional Configuration

Air assist connection faces passenger's side

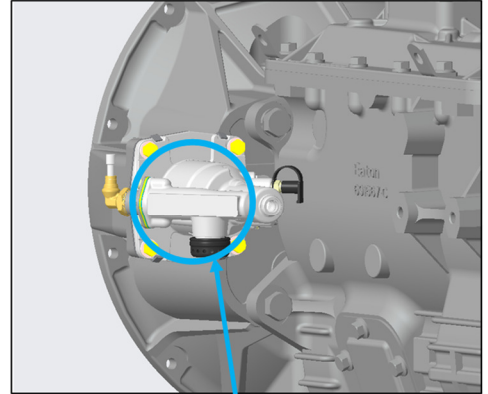

Standard Configuration

Air assist connection faces driver's side

Notes:

1. The actuator should never be flipped upside-down to achieve PTO clearance.
2. The bleed nipple must always be above the centerline.
3. The drain valve should always be below the centerline.

REAR ENGINE PTO

Rear Engine PTO (REPTO) is commonly used in cement mixer and feed lot applications. The REPTO is driven off the rear gear train on the engine. There is a 1350/1410 flange on the bell housing in the 1 o'clock position that can be used to attach a hydraulic pump or driveshaft. The REPTO flange will always be turning when the engine is running and the output rotation is the same as the engine. The Cummins ISL9 and PX-9 REPTO turns at a rate of 1.15:1.

REMOTE PMC CONNECTIONS

There are options to control PTO functionality from the following locations.

- Engine Bay – Hardwired option only
- RP1226 Connection in the Cab – CAN bus connection only
- BOC/BOS – Hardwired and CAN bus connections
- EOF – Hardwired and CAN bus connections

There are options available for the body builder to specify controller speeds of 250 kbps or 500 kbps.

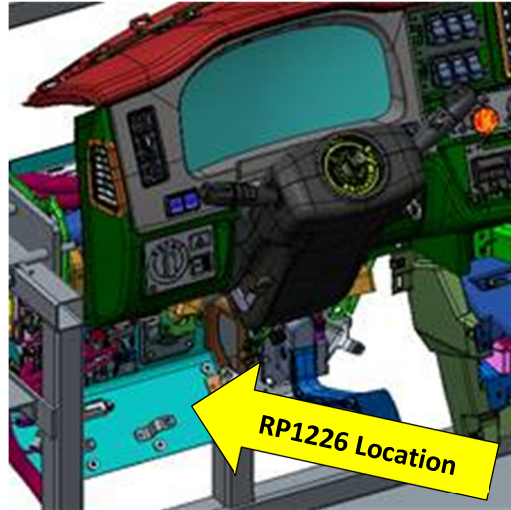

PTO CAN functionality may be accessed in the cab through the RP1226 connector and remotely through the body connectors K-CAN (E-3375-021) and B-CAN (DTM06-2S-EP10) Connectors.

PTO hardwired functionality may be accessed in the engine bay or on the frame through optional the 12-Way connector.



**12-Way Deutsch
Connector**

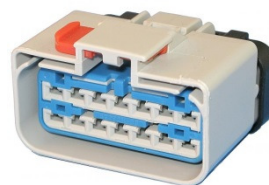

**RP1226 Delphi
Connector**

Pin-out information for the PTO connectors can be found in the Electrical Section

SECTION 9 AFTERTREATMENT

INTRODUCTION

The following section is designed to give you information regarding the aftertreatment systems on Peterbilt chassis.

All Peterbilts equipped with 2021 emission level engines will utilize Selective Catalyst Reduction (SCR). SCR is a process in which Diesel Exhaust Fluid (DEF) is injected into the exhaust downstream of the engine. DEF is converted to ammonia by the heat of the exhaust system. Inside of the SCR canister, a catalyst causes a chemical reaction to occur between the ammonia and NOx, turning it into water and nitrogen. For more information on the specific details of how SCR works, please contact your local Peterbilt dealer.

GENERAL GUIDELINES FOR DEF SYSTEM

The installation of the DEF tank is a critical component of the Aftertreatment system. While Peterbilt does not recommend relocating the DEF tank, there are applications and body installations that will require it. The guidelines below must be strictly followed by any entity relocating the tank. Failure to follow the guidelines completely and accurately may result in engine shut-down situations.

PACCAR-approved DEF hoses are required when retrofitting for system to function properly. The use of unapproved hoses for DEF lines will void warranty and may cause engine shut-down situations. The DEF pump (or Supply Module) cannot be relocated from the DEF tank.

Peterbilt offers a variety of DEF tank sizes to meet every application. The DEF tank volume is regulated by the EPA Peterbilt advises against modifying the tank volume after the truck has been delivered from the factory. These are estimated nominal (published) maximum fuel capacities for various DEF tanks, engines, and fill ratios.

TABLE 9-1. DEF Fuel Ratios

		FUEL VOLUME ALLOWED (USABLE GALLONS)	
		Standard DEF-Fuel Ratio (1.25:1-1.99:1)	Optional DEF-Fuel Ratio (2:1 or greater)
DEF Tank	Capacity (Gal)	PX-7/PX-9	PX-7/PX-9
SMALL	5.5	88	55
LARGE	15	240	150

DEF SYSTEM SCHEMATICS

On most Peterbilt chassis, the DEF Supply Module (or pump) is integrated into the DEF tank assembly. See page 9-3 for assembly relocation requirements.

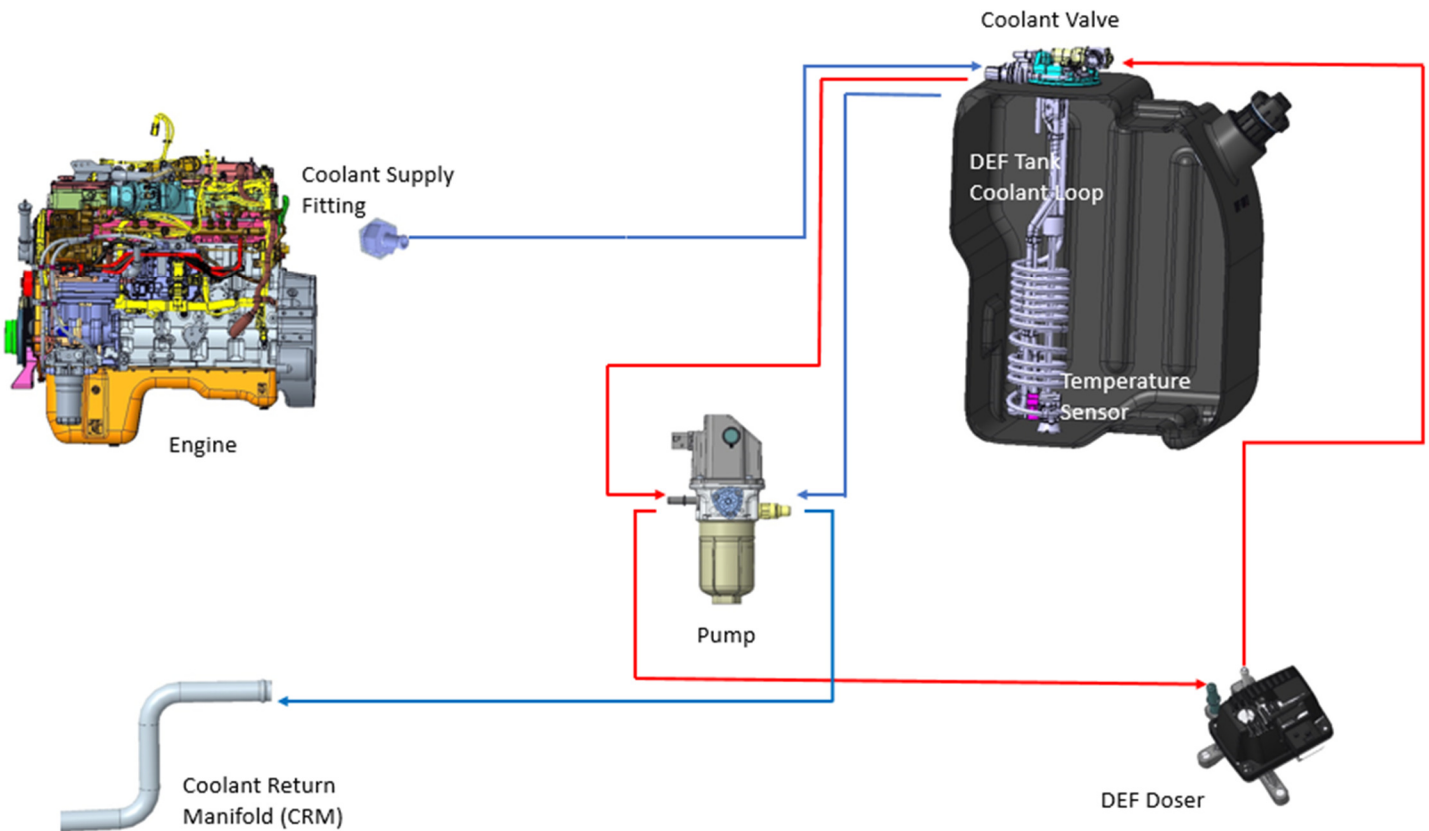

FIGURE 9-1. DEF System Schematic

DEF will freeze at approximately 11° F. In order to keep DEF from freezing, all tanks will be heated with engine coolant. The following schematic shows the routing of these lines. It is critical that the system is not compromised in any manner.

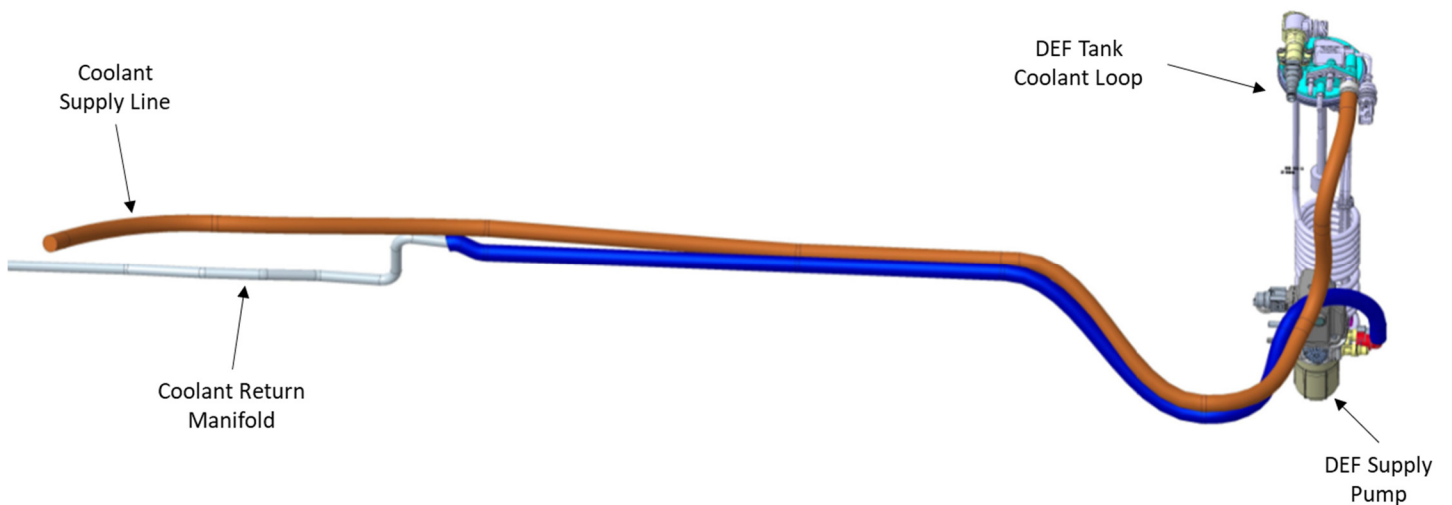

FIGURE 9-2. DEF Coolant Routing Schematic

INSTALLATION REQUIREMENTS AND DIMENSIONS FOR DEF SYSTEM

When relocating any DEF system component, the locations must meet all guidelines described below. Failure to comply may result in non-conformance to EPA standards and engine shutdown.

General clearances, routing guidelines, and installation requirements must be followed. See section 10 of this manual for general routing guidelines and clearances. The maximum DEF hose line length is 5.5 meters (216.5").

If the DEF tank is relocated, the coolant lines will need to be modified. During this process if the tank is moved forward on the chassis (closer to the engine) it is necessary to remove excess coolant lines and maintain the original routing path. If the tank is moved rearward on the chassis the additional length of cooling line required to complete the installation must be installed in a straight section of the existing coolant routing lines. This process minimizes the change in coolant flow and mitigates the risk of increased flow restriction. Changes in flow restriction are added with excessive line length and hose bends. Work with your local Peterbilt dealer if you are unsure about coolant line modifications.

DEF ASSEMBLY RELOCATION - SUPPLY MODULE REQUIREMENTS

The Supply Module (or Pump) standard mounting location is on the DEF tank assembly. The pump cannot be removed from the DEF tank assembly. However, the assembly as a whole may be relocated. Body builders should follow the location and length restrictions above. Additionally the supply module must be mounted with the filter cap oriented downwards within $\pm 45^\circ$ of vertical (or a 90° inverted cone as shown in figure 9-3). The supply module should be located in a space that will minimize its vulnerability to road debris. Serviceability of the supply module filter should be considered, and adequate space for filter access and removal should be given (at least 5").

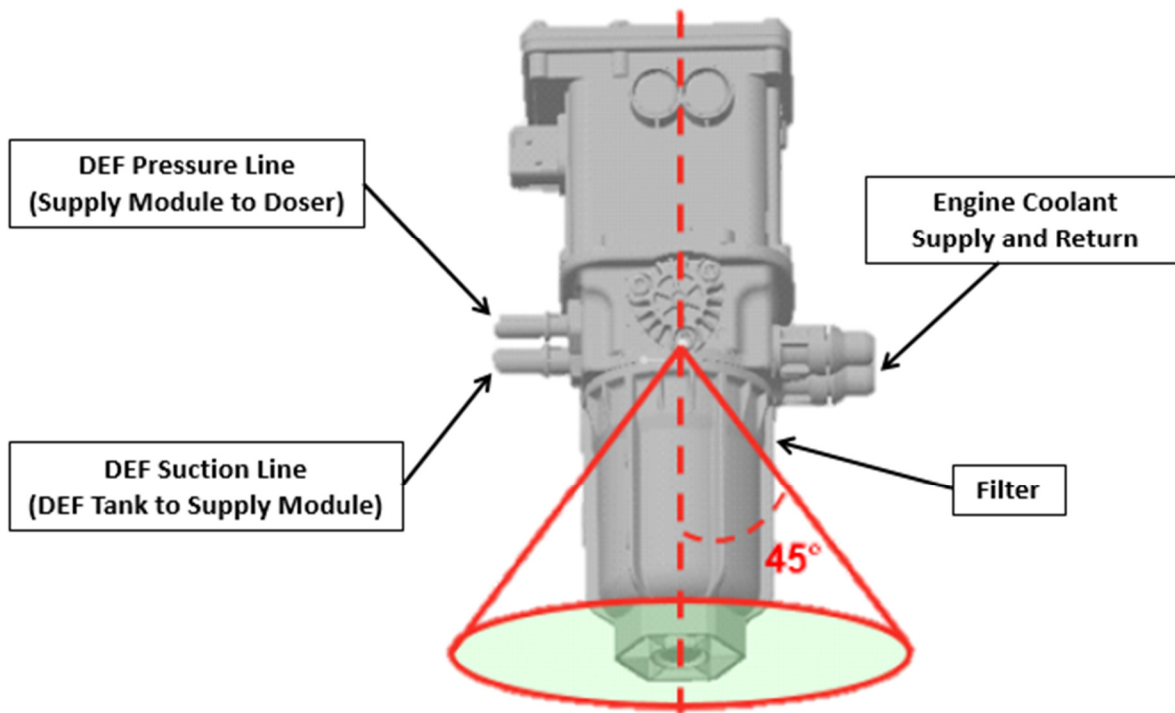

FIGURE 9-3. Supply Module Mounting Angle Limits

ROUTING TO THE DOSING MODULE (INJECTOR)

A DEF pressure line “trap” is not required for EPA 2017 and later emissions level engines. The dosing module (injector) no longer needs to be purged and relative heights of components are no longer critical. See Figure 9-4 below for typical routing with RHUC exhaust and LH DEF tank shown. Figure below shows a typical coolant line routing.

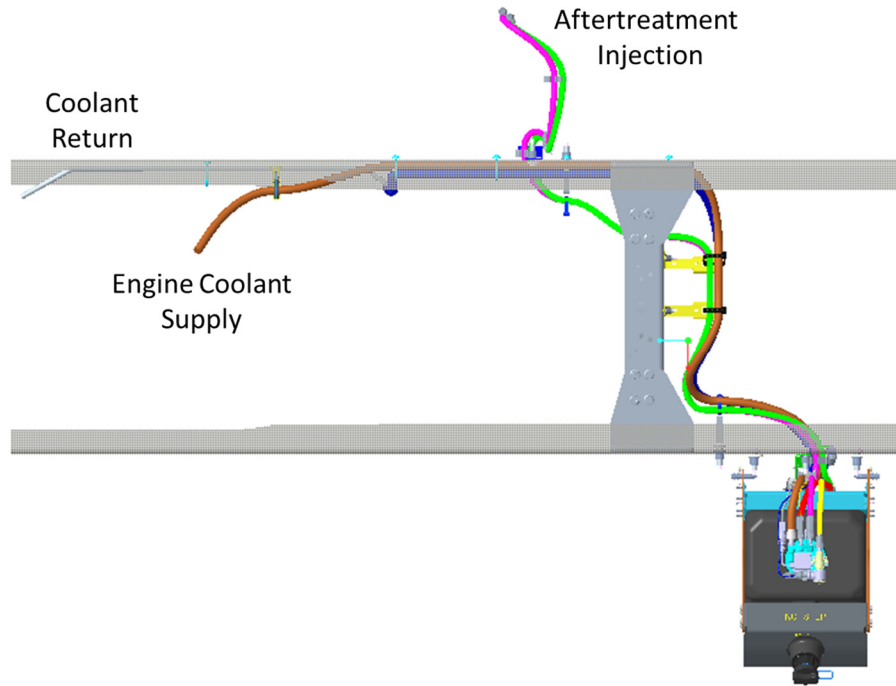

FIGURE 9-4. Routing for DEF and Coolant Lines

SECTION 10 ROUTING

INTRODUCTION

This section specifies the general requirements for securing hoses and electrical wires to present an orderly appearance, facilitate inspection and maintenance, and prevent potential damage to these lines.

DEFINITIONS

Bundle: Two or more air, electrical, fuel, or other lines tied together to form a unitized assembly.

Clamp: A cushioned rigid or semi-rigid, anti-chafing device for containing the bundle and securing it to the frame or other structural support. Standard clamps have a black elastomer lining. High temperature clamps (e.g., those used with compressor discharge hose) have a white or red elastomer lining (most applications for these are called out in the bills of material). An assembly of two clamps fastened together to separate components is referred to as a “butterfly” clamp. Note: the metal portion of clamps shall be stainless steel or otherwise made capable, through plating or other means, of passing a 200 hour salt spray test per ASTM B117 without rusting.

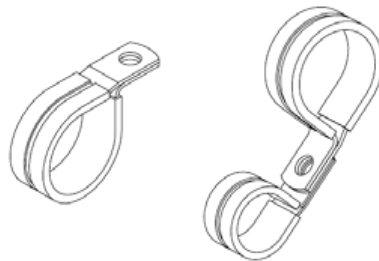

FIGURE 10-1. Clamp and Butterfly Clamp

Butterfly Tie: A tough plastic (nylon or equivalent) locking dual clamp tie strap used to separate bundles or single lines, hoses, etc. These straps must be UV stable. (Tyton DCT11)



FIGURE 10-2. Butterfly Tie

Tie Strap: A tough plastic (nylon, or equivalent) locking strap used to tie the lines in a bundle together between clamps or to otherwise secure hoses and wires as noted below. Straps must be UV stable.

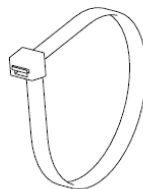

FIGURE 10-3. Tie Strap

Button Tie Strap: A tough plastic (nylon or equivalent) locking strap used to secure lines to the frame or other structural support. Straps must be UV stable.

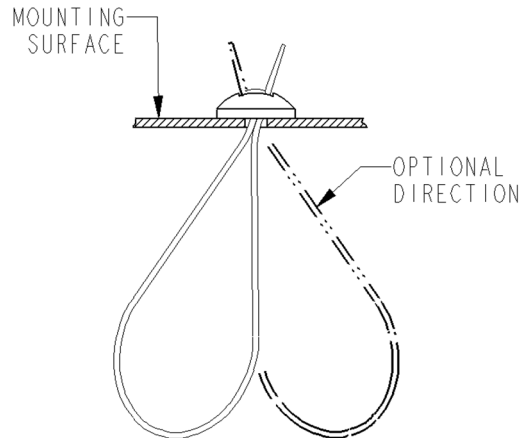

FIGURE 10-4. Button Tie Mount.

Fir Tree Mount: A tough plastic mount, inserted into a bracket or other intended support structure, used for securing routed bundles via a tie strap. Mounts must be UV stable

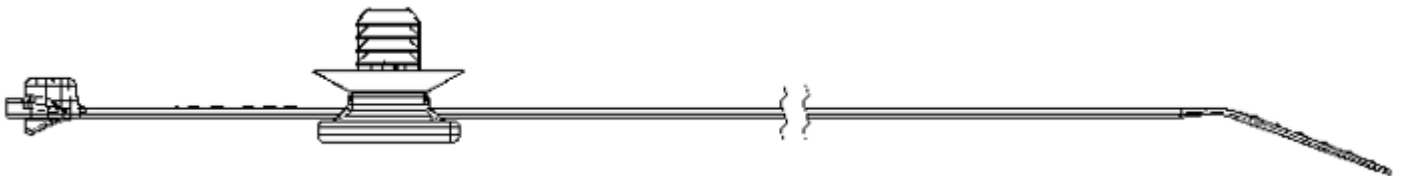

FIGURE 10-5. Fir Tree Mount

Heavy Duty (HD) Mount: A black rigid device used for securing a tie strap to the frame or other structural support. Mounts are made of impact modified, heat stabilized UV resistant nylon capable of continuous operation between temperatures 220°F (150°) and -40°F (-40°).

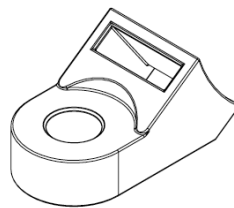

FIGURE 10-6. Heavy Duty (HD) Mount.



NOTE: Heavy duty tie straps 0.50in (12.7mm) wide (Tyton T255ROHIR or similar) shall be used whenever HD mounts are specified, although 0.25in (6.4mm) tie straps may be used in some specified applications.

Excess of material: More than 3 inches of slack for every 18 inch section of hose routing, except for air conditioner hoses.

Shortness of material: Less than 1 inch of slack on an 18 inch section of hose routing.

ROUTING REQUIREMENTS

ELECTRICAL WIRING

- Electrical ground wire terminals must be securely attached, and the complete terminal surface must contact a clean bare metal surface. See R414-558 for grounding wire connection practice. Apply electrical contact corrosion inhibitor Nyogel 759G grease (made by William F. Nye, Inc., New Bedford, MA) per R414-558.
- Don't bend wires or use tie straps within 75 mm (3 inches) of (connected) wire connectors or plugs
- Electrical wiring must be routed so that other components do not interfere with it
- Electrical wiring must be routed away from moving components so that at least 13.0 mm (0.5 in.) of clearance exists when the component is in operation and at maximum limits of the component's travel
- Electrical wiring must be protected in the locations they are routed
- Electrical wiring must be routed to avoid heat sources
- Electrical wiring must be secured to a crossmember when going from one frame rail to the other
- When crossing other components, electrical wiring must have a covering of convoluted tubing, PSA tape, or must be separated from the component with a standoff or butterfly clamp
- Electrical wiring must not be routed directly over a sharp edge unless separated from the edge by a clip, standoff bracket, or similar spacing feature that prevents any risk of chafing or cutting
 - Alternatively, the installation of windlace applied to the edge along with PSA tape or convoluted tubing on the harness is acceptable
- Electrical wiring must be routed in a way that will not place strain on connectors.

WIRES IN BUNDLES

Electrical wires (other than the exceptions covered below) running parallel with air or coolant hose bundles, may be included in the bundle if they are isolated from the hoses with a covering of convoluted plastic tubing.

EXCEPTIONS:

Battery cables (including jump start cables) may be bundled with or tied to the charging wire harness. They shall not be bundled with or tied directly to any other components, including hoses, wires, or bundles. They shall be separated from other routed components using butterfly ties at intervals not exceeding 18 inches (356 mm). Battery strap (W84-1000) tie down shall be used without exception to secure battery cables to frame mounted or other major component (e.g. engine, transmission, etc.) mounted standoffs at intervals not exceeding 18 inches (356 mm). The (positive) battery cable shall be covered with convoluted plastic tubing from terminal to terminal.

110/220 volt wires for engine heaters, oil pan heaters, transmission oil heaters, and battery pad warmers shall not be included in any hose/wire bundle with a fuel hose. Individual heater wires not in a bundle shall be separated from other components by using butterfly clamps or butterfly ties at intervals not exceeding 18 inches (356 mm). Heater wires with a secondary covering shall be covered with convoluted tubing whether they are in bundles or not.

WIRES CROSSING OTHER COMPONENTS

Electrical wires crossing over other components, such as lines, bolt heads, fittings, engine components lifting eyes, engine block, cylinder head, etc., close enough to rub shall be isolated with a covering of convoluted tubing and separated from the component by using butterfly clamps, butterfly ties, or plastic sheathing. 110/220 volt engine heater wiring shall be installed with butterfly ties or butterfly clamps

PIPING

Use no street elbows in air brake, water, fuel, or hydraulic systems unless specified on the piping diagram and the build instructions.

Use no elbows in the air brake system unless specified on the air piping diagram and the build instructions.

HOSES CROSSING COMPONENTS

Hoses crossing over other components close enough to rub shall be protected with a secured covering of convoluted plastic tubing (part number K344-813), another section of hose, or plastic sheathing (part number K213-1312). The usage of butterfly ties or butterfly clamps are also recommended.

AIR COMPRESSOR DISCHARGE HOSES

Wires or hoses shall not be tied to the high temperature air compressor discharge hose. Hoses and wires may be routed across the air compressor discharge hose at a distance of 18 inches (457 mm) or greater from the compressor discharge port. In this case, the crossing hoses and wires shall be "butterfly" clamped to the air compressor discharge hose and covered with convoluted tubing at the clamp point (use high temperature clamps on the compressor hose).

BUNDLES

HD mount and tie strap or clamp shall be located at intervals not to exceed 18 inches (356 mm) along the bundle.

Regular tie straps shall be located at intervals not to exceed 7 inches (178 mm) between HD mount or clamps. Extra tie straps may be used as needed to contain the hoses and wires in the bundle.

ROUTING OF WIRES AND HOSES NEAR MOVING COMPONENTS

Wires and hoses shall be routed away from moving components, such as fans, shackle links, drivelines, steering linkages, etc. so that there is at least 0.5 inches (12.7 mm) clearance when the component is operating at its maximum travel limits.

A minimum clearance of 1.0 inch (25.4 mm) shall be maintained between steering axle tires (and associated rotating parts) in all positions and routed components, such as hoses, oil lines, wires, pipes, etc.

ROUTING OF WIRES AND HOSES NEAR EXHAUST SYSTEM

TABLE 10-1. Exhaust – System Clearance

Description	Shielded	Unshielded
Coolant hoses (Silicone, colored)	1" minimum	2" minimum
DEF hose (EPDM)	6" minimum	7" minimum
HVAC hoses, tubing, and hard lines	5" minimum	7" minimum
Electrical wires	6" minimum	8" minimum
Fuel hoses within 15" of the turbo over 15" from the turbo	n/a 2" minimum	4" minimum 3" minimum
Fuel tanks and hydraulic tanks crossing tank parallel to tank end of tank aluminum/ceramic-coated exhaust pipe crossing tank	n/a n/a n/a n/a	2" minimum 2" minimum 1" minimum 1.5" minimum
Air hose nylon wire braid	6" minimum 6" minimum	8" minimum 7" minimum

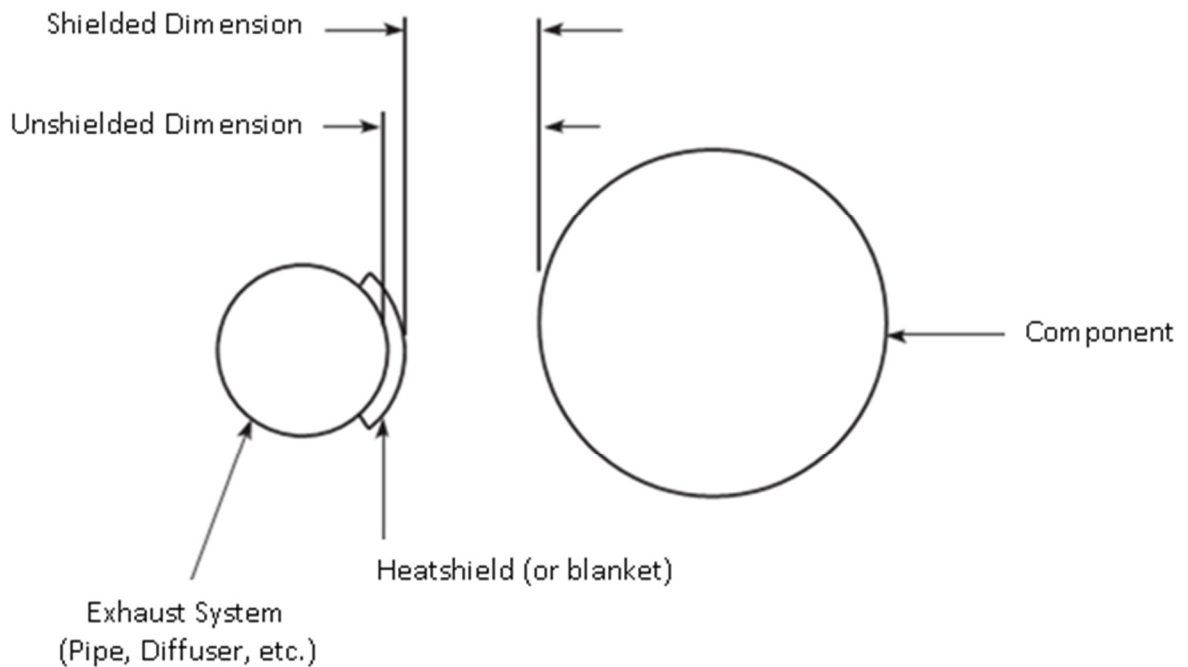

FIGURE 10-7. Definition of measurements.

This page is intentionally left blank.

APPENDICES

Revision Log

Revision Log – Medium Duty Body Builder Manual				
Revision	Author	Date of Publication	Pages #	Description of Changes
000	M. Evans	5/3/2021	n/a	Initial Release